



*Alfamacchine*

A Fletcher Company

EN

## **INSTRUCTIONS MANUAL**



**U500**  
*Memory Programmed/Single-Channel*

**U600**  
*Memory Programmed/Multi-Channel*

Name	<b>FRAME ASSEMBLING MACHINE</b>
Function	<b>ASSEMBLY OF FRAMES BY INSERTION OF METAL V-NAILS</b>
Model / Type	<b>U500-U600</b> (previous version MP - MC)
Serial number	
Year of manufacture	
Manual Revision	<b>02</b>

**PLEASE RETAIN FOR FUTURE REFERENCE**



Alfamacchine S.r.l.  
Via Selva 23/25  
47122 Forlì - Italy

**DICHIARAZIONE DI CONFORMITA' CE  
CE CONFORMITY DECLARATION**

Il Fabbricante / the Manufacturer  
con sede legale in / Address

**Alfamacchine S.r.l.**  
Via Selva, 23/25 47122 Forlì - Italy

**DICHIARA, / Hereby DECLARES,**

sotto la propria responsabilità,  
che la macchina:

under its sole responsibility,  
that the machine:

Denominazione / Product Name : FRAME ASSEMBLING MACHINE

Funzione / Purpose : ASSEMBLY OF WOODEN AND SYNTHETIC MDF MOULDINGS USING METAL V-NAILS

Modello/ Model Name : **U500**

Tipo / Type : ELECTRO-PNEUMATIC

Numero di Serie / Serial Number :

E' CONFORME ALLE DISPOSIZIONI PREVISTE DALLE DIRETTIVE:  
COMPLIES WITH THE BELOW MENTIONED STANDARDS AND DIRECTIVES:

- 2006/42/CE, Direttiva Macchine / Machinery Directive
- 2004/108/CE, Direttiva EU600 / EU600 Directive

poiché rispetta tutti i requisiti essenziali di sicurezza e sanitari che le concernono.  
because it complies with all the essential safety health which affect

Fascicolo Tecnico costituito presso : ALFAMACCHINE S.R.L.  
Technical File drawn up by: ALFAMACCHINE S.R.L.

Forlì ,

\_\_\_\_\_  
Data / Issued Date :

\_\_\_\_\_  
Firma il Legale rappresentante / Signature of representative

**Alfamacchine S.r.l.**  
Via Selva 23/25  
47122 Forlì - Italy**CE DECLARATION OF CONFORMITY**  
**CE CONFORMITY DECLARATION**Il Fabbricante / the Manufacturer  
con sede legale in / Address**Alfamacchine S.r.l.**  
Via Selva, 23/25 47122 Forlì - Italy**DICHIARA, / Hereby DECLARES,**sotto la propria responsabilità,  
che la macchina:under its sole responsibility,  
that the machine:

Denominazione / Product Name : FRAME ASSEMBLING MACHINE

Funzione / Purpose : ASSEMBLY OF WOODEN AND SYNTHETIC MDF MOULDINGS USING METAL V-NAILS

Modello/ Model Name : **U600**

Tipo / Type : ELECTRO-PNEUMATIC

Numero di Serie / Serial Number :

E' CONFORME ALLE DISPOSIZIONI PREVISTE DALLE DIRETTIVE:  
COMPLIES WITH THE BELOW MENTIONED STANDARDS AND DIRECTIVES:

- 2006/42/CE, Direttiva Macchine / Machinery Directive
- 2004/108/CE, Direttiva EU600 / EU600 Directive

poiché rispetta tutti i requisiti essenziali di sicurezza e sanitari che le concernono.  
because it complies with all the essential safety health which affect

Fascicolo Tecnico costituito presso : ALFAMACCHINE S.R.L.  
Technical File drawn up by: ALFAMACCHINE S.R.L.

Forlì ,

Data / Issued Date :

Firma il Legale rappresentante / Signature of representative

# U500

*Memory Programmed/Single-Channel*

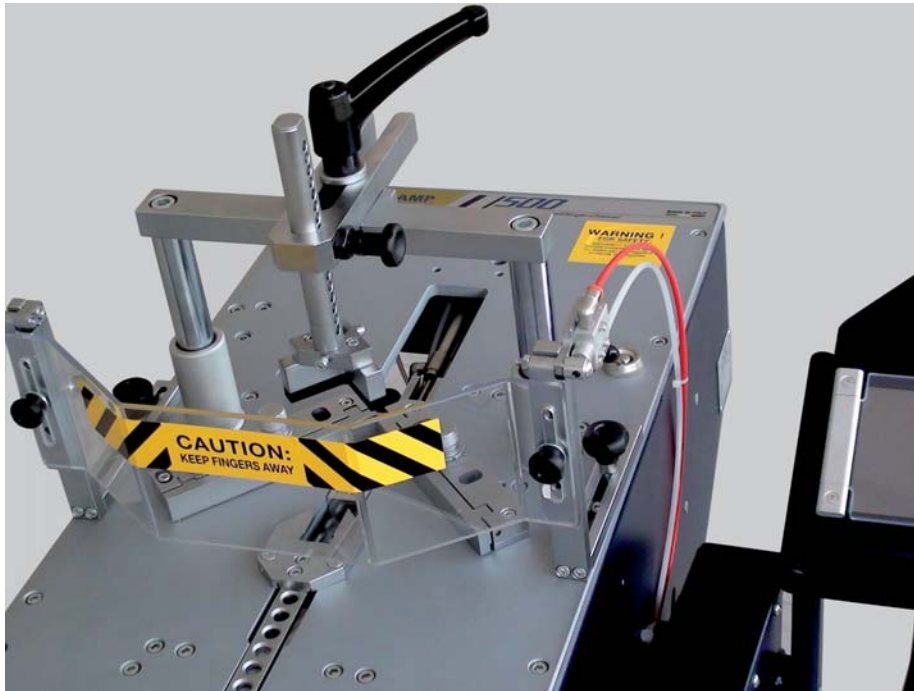

# U600

*Memory Programmed/Multi-Channel*

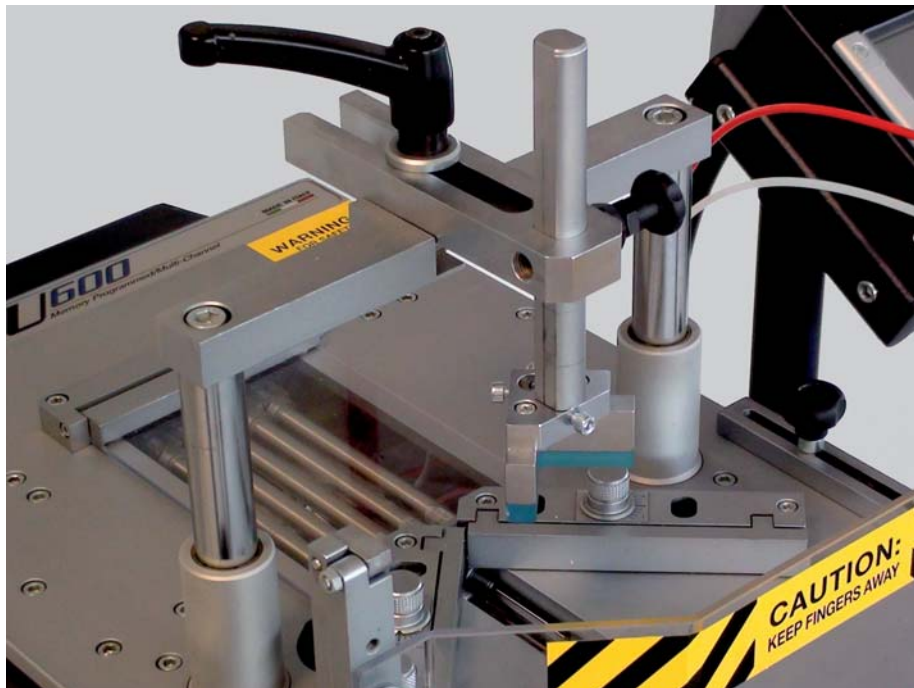

# EN TRANSLATION OF THE ORIGINAL INSTRUCTIONS

## INDEX

<b>1. INTRODUCTION TO USE</b>	<b>2</b>
1.1. HOW TO CONSULT THIS MANUAL AND THE SYMBOLS ADOPTED	2
1.2. WARNING STICKERS - INDICATIONS (see figure)	2
1.3. TYPE OF USE AND CONTRAINDICATIONS	3
1.4. TECHNICAL FEATURES	5
1.5. PRODUCTS PROCESSED - HANDLED OR GENERATED	6
1.6. EMISSION OF AIRBORNE NOISE	6
1.7. RESIDUAL RISKS - GENERAL INFORMATION	7
1.8. RESIDUAL RISKS	7
1.9. INFORMATION ON EMC	8
1.10. DESCRIPTION OF SAFETY FUNCTIONS	8
1.11. DESCRIPTION OF THE MACHINE	10
1.12. MAIN MACHINE COMPONENTS	10
<b>2. INSTALLATION</b>	<b>14</b>
2.1. STORAGE	14
2.2. CHECKS ON RECEPTION	15
2.3. TRANSPORT, LIFTING AND HANDLING	15
2.4. LIFTING AND HANDLING	16
2.5. REMOVING THE PACKAGING	17
<b>3. PRELIMINARY PREPARATION AND ADJUSTMENT PROCEDURES</b>	<b>18</b>
3.1. POSITIONING	18
3.2. LEVELLING THE MACHINE	18
3.3. ASSEMBLY OF SEPARATELY SHIPPED UNITS	19
3.4. POWER SUPPLIES	21
<b>4. INITIAL START-UP AND USE OF THE MACHINE</b>	<b>24</b>
4.1. WORKSTATIONS AND OPERATORS' TASKS	25
4.2. DESCRIPTION OF ACTUATORS, SIGNALS AND ALARMS	27
4.2.1. COMMAND AND SIGNALLING ACTUATORS	27
4.2.2. START-UP FUNCTIONS	28
4.2.3. STOP FUNCTIONS (TIMED AND SAFETY STOPS)	28
4.3. CHECKS, ADJUSTMENTS AND START-UP	29
4.4. START-UP	29
4.4.1. CHECKS ON CYCLE START-UP AND PERIODICAL INSPECTIONS	29
4.4.2. PRODUCTION / PROGRAMMING PARAMETERS SETUP	32
4.4.3. MECHANICAL ADJUSTMENTS / MAINTENANCE	39
4.4.4. RESERVED PAGES	51
4.5. WORKING CYCLE	56
4.5.1. CYCLE STOP	57
4.5.2. SWITCH-OFF	57
<b>5. MAINTENANCE, TROUBLESHOOTING, AND CLEANING</b>	<b>58</b>
5.1. MAINTENANCE TECHNICIAN REQUIREMENTS	58
5.2. WORK STATIONS AND MAINTENANCE TECHNICIAN DUTIES	58
5.3. MAINTENANCE PRESCRIPTIONS	59
5.4. GENERAL WARNINGS	59
5.5. ISOLATION FROM EXTERNAL ENERGY SOURCES	60
5.6. ROUTINE MAINTENANCE	60
5.7. TASKS THAT CAN BE PERFORMED BY THE OPERATOR	61
5.8. TASKS THAT CAN BE PERFORMED ONLY BY MAINTENANCE TECHNICIANS	62
5.9. CLEANING	64
5.9.1. CLEANING THE TOUCHSCREEN	65
5.9.2. REPLACING THE PROTECTIVE FILM ON THE DISPLAY	65
5.10. LUBRICATION	66
<b>6. TROUBLESHOOTING AND RELEASE OF MOVING PARTS</b>	<b>68</b>
<b>7. REINSTALLATION AND REUSE</b>	<b>70</b>
<b>8. EXTINGUISHING MEDIA</b>	<b>70</b>
<b>9. SCRAPPING AND DISPOSAL</b>	<b>70</b>
9.1. SCRAPPING	70
9.2. DISPOSAL	71
<b>PNEUMATIC DIAGRAM U500</b>	<b>72</b>
<b>PNEUMATIC DIAGRAM U600</b>	<b>73</b>
<b>CAPS PNEUMATIC DIAGRAM</b>	<b>74</b>
<b>WIRING DIAGRAM U500</b>	<b>75</b>
<b>WIRING DIAGRAM U600</b>	<b>76</b>
<b>CAPS WIRING DIAGRAM</b>	<b>77</b>
<b>EXPLODED-VIEW DRAWINGS U600-U500</b>	<b>78</b>

**! DANGER - WARNING**  
**BEFORE USING THE MACHINE PLEASE READ THIS MANUAL CAREFULLY SO THAT YOU BECOME FAMILIAR WITH THE MACHINE, ITS ENVISAGED USE AND ANY RISKS ASSOCIATED WITH IT.**

Keep the Use and Maintenance Manual in good condition: Remember, it is an integral part of the machine. Always refer to the manual to get best machine performance in maximum safety while performing the operations described therein.  
This manual must be kept in an easily accessible place, near the machine, at all times so that it can be consulted whenever necessary.

**! DANGER - WARNING**  
**USE THE MACHINE SOLELY AND EXCLUSIVELY FOR THE USES INDICATED AND IN ACCORDANCE WITH THE RECOMMENDATIONS PROVIDED IN THIS MANUAL. NEVER TAMPER WITH IT, FORCE IT OR USE IT IN ANY INAPPROPRIATE MANNER.**

## 1. INTRODUCTION TO USE

### 1.1. HOW TO CONSULT THIS MANUAL AND THE SYMBOLS ADOPTED

Please pay particular attention to the words "DANGER – WARNING", "DANGER – CAUTION" and "NOTES" as used in this manual. To draw the user's attention to certain information and provide warning messages, the operations described in this manual are accompanied by symbols and notes to highlight the presence of any hazards and indicate the safe use of the equipment. These symbols and notes belong to various categories as indicated below:

**! DANGER – WARNING: IMPORTANT INFORMATION CONCERNING GENERAL SAFETY.**

**!** **DANGER-CAUTION: highlights situations where careful and sensible actions are essential.**

**🔍** **NOTES: information of a technical nature.**

### 1.2. WARNING STICKERS - INDICATIONS (see figure)

Etichetta	Descrizione
	Wear protective goggles.
	Wear protective gloves.
	Wear safety footwear
	Wear ear defenders.
	Risk of impact against obstacles: affixed on the corners of the guards.



Safety warning on machine use



230V - 50-60Hz

Part of the equipment remains live even when the door is open and with the electrical power switch turned on.

To turn off the power supply act on the upline cut-off device on the power supply.



EC dataplate



Sticker	Description
<b>DISCONNECT ONLY WHEN THE MACHINE IS STOPPED</b>	Indicates the method for disconnecting the plug from the power socket.
<b>LIVE EQUIPMENT EVEN WHEN THE DOOR IS OPEN. TO CUT OFF THE POWER SUPPLY ACT ON THE MAIN ELECTRICAL ENCLOSURE POWER SWITCH</b>	Indicates how to disconnect the power supply.
<b>DISCONNECT THE POWER SUPPLY BEFORE OPENING THE ELECTRICAL ENCLOSURE</b> Access to the powered electrical enclosure is permitted only to specifically trained and duly informed technicians who must use a special key or tool to open it. It is prohibited to carry out work on live equipment. Any exceptions to this prohibition must be authorized by the person in charge and are subject to the adoption of all envisaged safety regulations.	Indicates how to access the electrical enclosure.

### 1.3. TYPE OF USE AND CONTRAINDICATIONS.

#### PERMITTED USE

The machine described herein is designed to be run by 1 operator suitably trained and instructed with regard to residual risks. The operator must have the same skills, in terms of safety, as the maintenance technicians and adequate professional competence.

During its PERMITTED AND REASONABLY PREDICTABLE USE, the machine may be used exclusively:

- to work with wooden mouldings of various hardness, with multiple surface finishes, for the purpose of making frames for pictures, mirrors, display cases, cupboard doors etc.) in accordance with the characteristics described in the heading "Products Processed - Handled or Generated". Use of the machine to perform processes other than those described in this manual is to be considered improper and therefore strictly prohibited.
- with the products (and materials) described and having the dimensions specified in the heading "TECHNICAL CHARACTERISTICS".

It is also compulsory:

- for the machine to be used by one operator only who has received adequate training/information concerning machine operations, performance and any hazards associated with its use.
- to ensure no exposed persons are present in the machine's operating area before proceeding with any operations whatsoever.
- to check the perfect condition of all the safety devices before starting to work with the machine.
- to ensure, when the machine is placed on the factory floor where it is to be used, that it is installed on a level, smooth and perfectly horizontal surface. The floor must have an adequate load bearing capacity to support the weight of the machine.
- to check, prior to starting work with the machine, the conditions of ambient lighting and ensure there are no areas of shadow, glare, or potentially hazardous strobe effects.
- in the event of grave danger, to press one of the emergency stop buttons on the electrical panel.
- to disconnect, prior to starting any work on the machine, the main electrical and compressed air supplies, to safely discharge any residual energy in the machine circuits, and wait for all parts at high temperatures to cool down adequately.



## **UNINTENDED USE**

### **DANGER - WARNING** **THE MACHINE MUST NOT BE USED IN A PROHIBITED MANNER. SPECIFICALLY:**

- it cannot be operated with parameters different to those shown in the "TECHNICAL CHARACTERISTICS" table or with products and/or materials with different characteristics to those previously described in the heading "TECHNICAL CHARACTERISTICS".
- all uses of the machine other than those described in this manual are construed as improper and as such the manufacturer declines all liability.
- the user is responsible for any damage resulting from failure to observe the operating conditions agreed at the time of technical specification and order confirmation.

## **FORBIDDEN USE**

### **DANGER - WARNING** **FURTHERMORE IT IS PROHIBITED TO USE THE MACHINE IN AN INCORRECT MANNER, IN PARTICULAR:**

- never leave the loaded machine unattended,
- never use flammable, corrosive or toxic substances to clean the machine,
- never allow unauthorized personnel to use the machine,
- never smoke or use open flame equipment or handle incandescent material, unless adequate safety measures have been adopted,
- never activate or adjust the control and locking devices, such as knobs or similar devices, during machine operation or when not authorized to do so,
- never hang objects or weights on the machine,
- never use the machine with the safety guards open, incorrectly fastened, or removed,
- never use the machine with the safety microswitches and interlocking safety devices inhibited and, in general, with any safety and/or protective device (mechanical or electrical) deactivated and/or non-functional,
- never partially or totally by-pass, remove, modify or in any way render ineffective the guards, safety microswitches and warning signs,
- use of the machine is forbidden when the user has not adopted all the necessary measures to eliminate the residual risks as indicated in this instruction manual,
- never use the machine for operations other than those explicitly indicated in this instruction manual,
- never use the machine in environments for which it has not been designed unless all necessary safety measures have been adopted beforehand,
- the machine must not be used by untrained personnel
- foodstuffs must not be brought into contact with the machine,
- it is prohibited to activate the control devices for machine movements without first checking and ascertaining the absence of persons in the danger areas subject to machine movements,
- it is prohibited to enter the operating / danger zone of the machine during control of the machine's moving parts,
- it is prohibited to enter the machine working area with any part of the body, hands and arms included, before hazardous moving elements have come to a complete standstill.
- it is prohibited for the machine operator and maintenance technician to enter the danger zones to perform cleaning, lubrication, maintenance operations etc. without having first set the power cut-off switches to "ZERO" and padlocked them in this position,
- the machine must not be used in critical conditions of stability, i.e.:
  - when placed on a support surface which is not perfectly horizontal and smooth, or does not have an inadequate load capacity as indicated in this manual,
  - outdoors or worksites with open windows and doors,
- the following are strictly prohibited:
  - processing of materials and products that are not expressly indicated in the present manual,
  - processing of metal materials made of aluminium, lightweight alloys, and steel and its alloys.

### **DANGER – CAUTION** ***The manufacturer cannot be held liable for any faults caused by unreasonable, improper and/or incorrect use of the machine.***

The user is anyway responsible for all damage deriving from failure to comply with the specified terms of use. For any further information always consult the manufacturer's engineering department.

The user is always responsible for providing suitable personal protective equipment to machine operators and for informing them on the permissible uses of the machine.

## **PERSONNEL AUTHORIZED TO USE THE MACHINE**

This machine has been designed and manufactured to be used by qualified personnel with adequate training, experience and skills in accordance with the characteristics described below:



#### Operators / Apprentices:

- may be male or female
- must be aged 14 or over
- must have full use of both hands
- must have no physical or mental disabilities
- must know and fully understand the contents of the user manual.

#### PERMITTED AMBIENT CONDITIONS AND OPERATING LIMITS



#### **DANGER - WARNING**

**THIS MACHINE IS NOT SUITABLE FOR USE IN POTENTIALLY EXPLOSIVE ATMOSPHERES.  
INSTALLATION AND USE IN SUCH AN ATMOSPHERE IS THEREFORE PROHIBITED.**



*NOTE - Details of the "Service Conditions" specifications are to be found inside the document "APPENDIX A" accompanying this manual.*

#### 1.4. TECHNICAL FEATURES

##### **U600 Machine characteristics**

Dimensions of the working bench (WxL).....	350X680mm - 14"x26"3/4
Max. machine length.....	730mm - 28"3/4
Machine width.....	800mm - 34"3/4
Minimum height of working bench from the floor.....	980mm - 38"1/2
Maximum height from the floor (highest point).....	1310mm - 52"
Weight.....	140Kg - 309lbs
Max. distance between V-nails.....	145mm - 5"3/4
V-nail magazine capacity U600.....	1100pz - 1100pcs
Max. quantity of V-nails inserted per position.....	9pcs
V-Nail insertion positions.....	Multiple
Max. distance between V-nails.....	145mm - 5"3/4

##### **Machine features - U500**

Dimensions of the working bench (WxL).....	350X680mm - 14"x26"3/4
Max. machine length.....	680mm - 26"3/4
Max. machine length.....	800mm - 34"3/4
Minimum height of working bench from the floor.....	980mm - 38"1/2
Maximum height from floor (highest point) 1310 mm-52"	
Weight.....	140Kg - 309lbs
Max. distance between V-nails.....	145mm - 5"3/4
V-nail magazine capacity U600.....	220pz - 220pcs
Max. quantity of V-nails inserted per position.....	9pcs
V-Nail insertion positions.....	Multiple
Max. distance between V-nails.....	145mm - 5"3/4

##### **Electrical power supply**

Voltage.....	110-230 V AC 50 / 60 Hz
Maximum installed power.....	400 W

##### **Compressed air supply**

Maximum permitted inlet pressure.....	8bar
Recommended operating pressure.....	4-6 bar (no lower than 2.5bar, no higher than 7bar)
Specific air consumption.....	5 NI

**V-nail characteristics**

V-nail type	Height mm
H3	3mm (optional)
H5	5mm
H7	7mm
H10	10mm
H12	12mm
H15	15mm

Material	Recommended sharpness
Soft wood and plastic	SW transparent stick
Medium wood	MW brown stick
Hard wood	HW green stick
Very Hard Wood and MDF	HS red stick



**1.5. PRODUCTS PROCESSED - HANDLED OR GENERATED**

The products handled by the machine described herein must be made up of wooden mouldings of various hardness, with multiple surface finishes, for the purpose of making frames for pictures, mirrors, display cases, cupboard doors etc..

The main technical characteristics of the products handled by the machine described herein are provided below.

DESCRIPTION OF PRODUCTS HANDLED	CHARACTERISTICS
Minimum/maximum width of moulding	6 / 105mm - 1/4" – 4"1/4
Minimum/maximum thickness of moulding	6 / 80 mm - 1/4" – 3"1/4
Maximum length of moulding*	Without extensions: Max. length = 700mm; Weight 10Kg
	With extensions: Max. length = 1700mm, Weight 25Kg

**1.6. EMISSION OF AIRBORNE NOISE**

**NOTE** – The manufacturer declares, under his own responsibility, that the machine produces a continuous equivalent A-weighted sound pressure level of 80 dB.

**! DANGER – WARNING:**  
TO AVOID THE DANGER OF HEARING DAMAGE CAUSED BY SHRILL OR INSISTENT NOISE, THE MACHINE OPERATOR AND MAINTENANCE TECHNICIAN MUST ALWAYS USE APPROPRIATE HEARING PROTECTION, SUCH AS HEARING DEFENDERS OR EARPLUGS.

## 1.7. RESIDUAL RISKS - GENERAL INFORMATION

This manual contains a list and description of the residual risks that could not be eliminated in the design stage and that therefore remain present on the machine.

For each risk, suitable instructions or prescriptions are given which the user must observe in order to avoid hazards affecting the machine operator, maintenance technicians, any exposed persons and the machine itself.

## 1.8. RESIDUAL RISKS

### Residual risk due to noise

As demonstrated by experimental tests, the machine produces a continuous equivalent A-weighted sound pressure level of 80 dB. To avoid the risk of hearing damage caused by shrill or insistent noise during machine use, in addition to being adequately informed and trained, the operator and maintenance technician must always use appropriate hearing protection, such as hearing defenders, earplugs or similar personal protection equipment to safeguard hearing.

**PPE to be used:**



Hearing protection

### Residual risk due to the combustibility of the substances used in the machine and the products handled by the same

To avoid the hazards resulting from:

- the ignition of substances used in the machine,
- residual risks associated with possible outbreaks of fire,

the employer, in addition to training and adequately informing the machine operator and maintenance technician on such risks, must provide permanent fire protection systems in the vicinity of the machine control station. Said systems must be suitable for the types of material which could catch fire.

**PPE to be used:**



Protective gloves



Safety footwear



Safety clothing

### Residual risk caused by piloting the valves with a special tool

There is a residual risk for the maintenance technician, when the safety guards are open and valve piloting is activated using the special tool, in order to check (during troubleshooting procedures) the operation of the pneumatically operated mobile elements, when energy remains accumulated inside the actuator cylinders.

Consequently, when the aforementioned activities are performed, the maintenance technician must make sure that no exposed persons are found near the pneumatically controlled mobile elements and in any case said mobile elements must only be activated if strictly necessary for pinpointing operating faults.

### Residual risk due to the presence of accumulated energy inside the pneumatic actuator cylinders

There is a residual risk for the maintenance technician when the machine is isolated from both the electrical power supply and the compressed air network, due to the presence of accumulated energy inside the actuator cylinders, when mobile guards are open caused by the presence of closed-centre valves and/or tanks which remain pressurized.

Please note that said piping is duly identified and indicated to distinguish it from all other piping installed on the machine.

Consequently, before carrying out any work on the aforementioned cylinders, in accordance with the instructions given in the actuator manuals supplied with the machine, the maintenance technician must neutralise the accumulated energy working in compliance with the safety regulations applicable to maintenance personnel, such as, for example, manual activation of the special tool for the piloting valves used to discharge stored energy.

Under no circumstances must the piping be disconnected if they still hold residual pressure.

### **Residual risk of finger crushing**

With the adjustable polycarbonate guard in the high or low position, there is a residual risk of finger crushing, for operators and maintenance technicians, inside the slot on the working bench along the stroke of the V-nail shooting unit.

Furthermore, it is to be pointed out that said finger crushing risks are present near each mobile element installed over the machine's working bench.

Consequently the operator and maintenance technician, as well as observing the instructions provided in this manual, must never place their fingers or any other part of the body in the zone indicated. What's more, workers must never wear rings, wrist watches, jewellery, torn clothing, scarves, ties or any other loose clothing or personal accessories that may constitute a risk. Make sure sleeves fit snugly around wrists and keep long hair tied back.

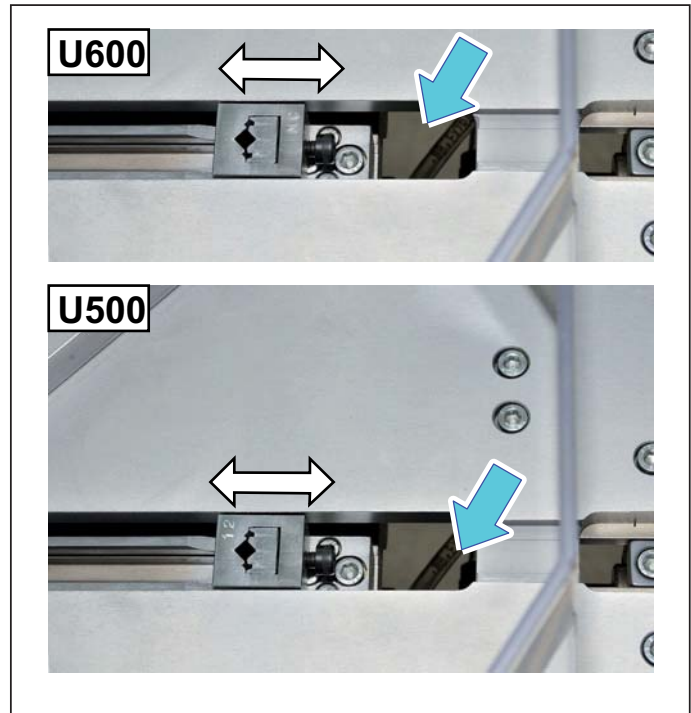

### **Residual risk due to electric shock hazard**

There is a residual risk for the electrical equipment maintenance technician, whenever he has to work inside the electrical enclosures, junction boxes or on electrical components in the presence of live voltage for the purpose of carrying out inspections, maintenance and operating tests which require interventions with the electrical equipment powered and/or with the guards removed.

Consequently maintenance electricians must work with extreme caution and observe the indications provided on the decals affixed near the aforementioned components.

Furthermore, interventions which require access into the aforementioned areas must be performed solely and exclusively by expert, authorized "maintenance electricians" who must strictly observe all the safety regulations concerning electrical systems.

## **1.9. INFORMATION ON EMC**

Electromagnetic emissions from the machine do not exceed the limits defined by the relative standards for the envisaged conditions of use. Testing was carried out in accordance with Standards EN 55014-1 and EN 55014-2.

## **1.10. DESCRIPTION OF SAFETY FUNCTIONS**

### **Protective devices installed on the machine**

**⚠ DANGER - WARNING**  
**IT IS STRICTLY PROHIBITED TO REMOVE THE SAFEGUARDS AND SAFETY DEVICES EXCEPT WHEN STRICTLY NECESSARY FOR THE PURPOSE OF CARRYING OUT MAINTENANCE WORK.**

When such safeguards and safety devices need to be removed all necessary measures must be adopted to highlight this situation immediately and minimise any possible associated hazards.

The safeguards and safety devices must be refitted as soon as the reasons for their temporary removal are no longer applicable.

Each operating unit of the machine is protected by a guard, which may also be a fixed guard designed to prevent access to dangerous parts, except:

- in the upper part of the working bench to perform adjustments, tooling, parts replacement, etc.
- in the lower part of the working bench to perform adjustments, tooling, parts replacement, etc.

## Machine guards and safety devices

Ref.	GUARDS / PROTECTIVE DEVICES – POSITION	TYPE OF SAFEGUARDED HAZARD
A	Moveable guard	The transparent polycarbonate panel stops access to the magazine on the U600 model
B	Fixed guard	Rear steel sheet panel secured in place with screws to prevent access to electromechanical and electronic components.
C	Adjustable guard	Polycarbonate panel secured to metal supports which can be adjusted by acting on the relative knobs, to prevent access to the vertical clamping unit.
D	Fixed guard	Front steel sheet panel secured in place with screws to prevent access to electromechanical and electronic components.

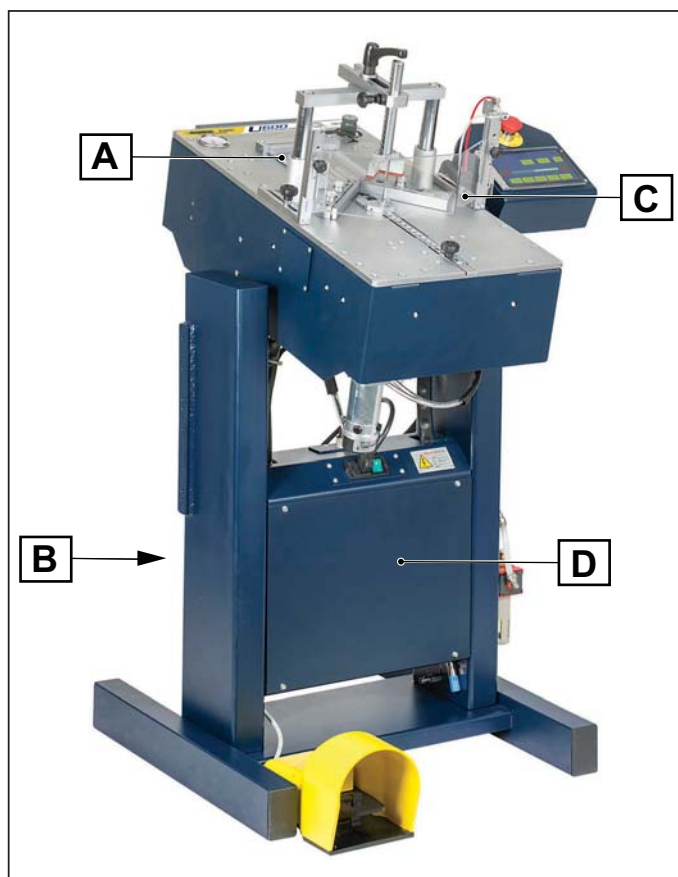

With regard to fixed guards the following specifications apply:

- The dimensions of fixed guards are such as to eliminate all openings to the protected dangerous work zone when the guards are correctly secured in place.
- Fixed guards that are not permanently welded to the machine are secured in place by screws that call for the use of special tools (Allen keys) and can only be removed, using the appropriate tool, by authorized maintenance technicians.
- access to areas protected by a fixed guard is allowed only for maintenance technicians. Irrespective of the circumstances, machine operators must never attempt to open a fixed guard.
- It is not possible to refit a guard incorrectly and leave potentially dangerous openings in the machine safeguards.
- If the guards are not fixed in their seats using the special screws, they will not remain lodged in their locations in the absence of the fastening elements.

In sizing and selecting the guards and safety devices, the possibility of access by persons aged 14 or over was used as a reference condition.



### DANGER - WARNING

**ACCESS TO AREAS PROTECTED BY A MOVABLE GUARD IS ALLOWED FOR BOTH THE MACHINE OPERATOR AND MAINTENANCE TECHNICIAN. IRRESPECTIVE OF THE CIRCUMSTANCES, THE MACHINE OPERATOR MUST NEVER ATTEMPT TO VOLUNTARILY CIRCUMVENT A FIXED GUARD.**

- access to areas protected by a fixed guard is allowed only for maintenance technicians. Under no circumstances must the machine operator ever attempt to voluntarily circumvent a moveable guard.
- Before starting the machine, all guards and safety devices must be correctly installed, adjusted/tuned and made functional, adhering meticulously and carefully to the indications provided in the installation, use and maintenance manuals accompanying said safety devices (all of which are supplied with the machine) and this instruction manual.
- The manufacturer strictly prohibits any tampering, even partial or momentary, with any of the safety devices present on the machine, because they are installed specifically to ensure the physical safety of operators and other persons present in the machine operating area.
- Violation of this regulation will give rise to risks and is in conflict with statutory legal regulations concerning safety in the workplace.



### 1.11. DESCRIPTION OF THE MACHINE

THE FRAME ASSEMBLING MACHINE in the U500 and U600 version is a machine for producing wooden frames. More specifically it joins together the frame mouldings (which maybe pre-glued or dry) using metal V-nails.

The machine is equipped with an electronic control system which is capable of performing the most varied operating cycles extremely quickly. Thousands of operating programs, corresponding to the different types and dimensions of the frames being made, can be stored in the machine's memory.

The machine can only operate in semi-automatic mode, based on a program which must be defined by the operator. The machine can use special Alfagraf V-nails with "Pulling Power" effect or standard V-nails.

In its basic configuration the machine is made up of a rigid steel structure, complete with base and a series of operating units and zones:

**1 working bench, complete with:**

- a double or single stopper device for immobilizing the mouldings,
- a system of alignment fences,
- a V-nail magazine,
- a V-nail insertion system which uses a pneumatic actuator,
- a series of electric and pneumatic actuators.

**1 base which supports the working bench, complete with:**

- electromechanical and electronic devices,
- pneumatic devices,
- a series of adjustable feet for machine levelling.

**1 control console with touch screen, complete with:**

- emergency stop button,
- touch screen for programming the operating cycles,
- electronic device.

The machine's AUTOMATIC FUNCTIONS, programming and operating sequence are electronically controlled.

### 1.12. MAIN MACHINE COMPONENTS

In its basic configuration the machine is made up of a series of operating units and zones, including:

Ref.	DESCRIPTION
A	Pneumatic panel
B	Electrical panel
C	Control console touchscreen panel
D	Working bench
E	Pedal button

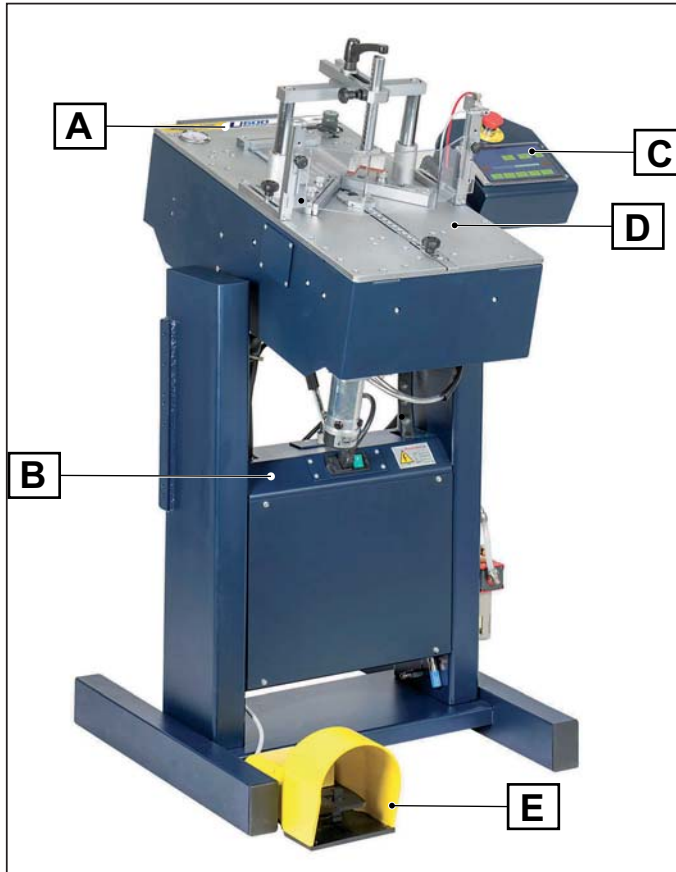

**Working bench**

The working bench is made up of the following main parts:

Ref.	DESCRIPTION
A	V-nail magazine
B	Vertical stopper unit support
C	Vertical clamp unit
D	Alignment guides
E	Horizontal clamping unit
F	Head sliding slot

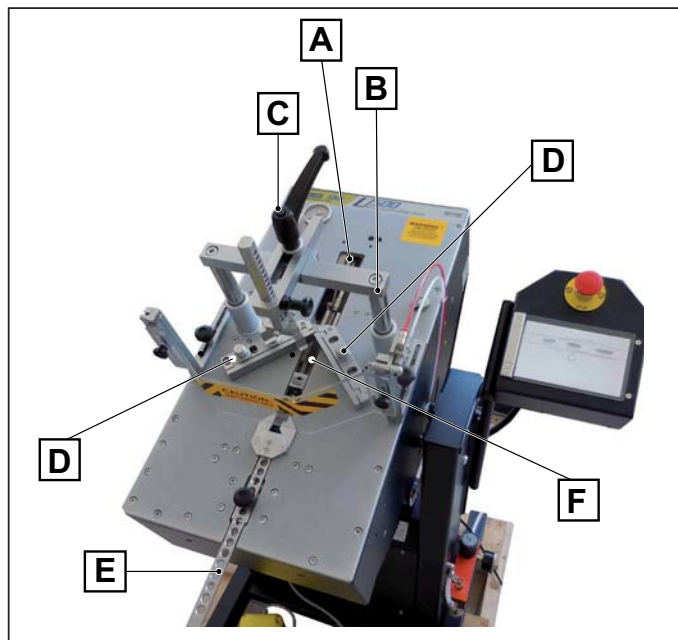

**V-NAIL MAGAZINE**

There are two types of V-nail magazine:

- a single magazine, installed on the U500 machine (G);
- a multiple magazine, installed on the U600 machine (L).

**Single magazine:**

In the U500 machine (G), the single magazine (H) can hold V-nails of different heights but only one V-nail size can be used at a time, depending on the nailing head installed.

When the size of the V-nails is changed the nailing head must also be switched over to match the V-nails used.

The V-nails are held in position by the V-nail pusher device (I).

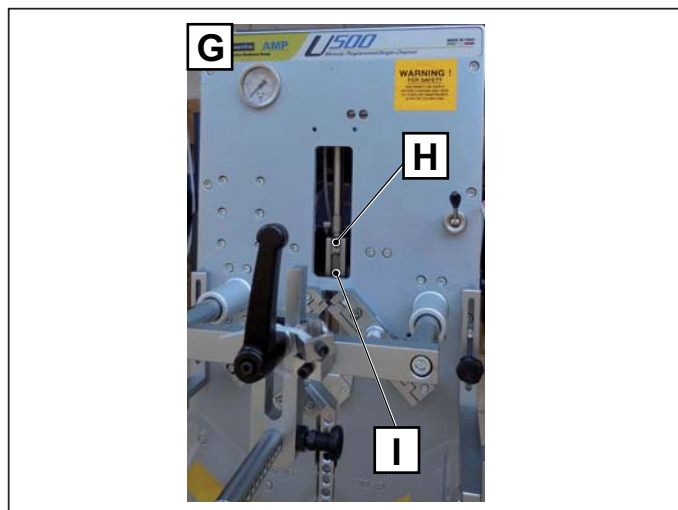

**Configurable multiple magazine:**

In the U600 machine (L) machine, the operator has 5 magazines (N) he can use, all mechanically set up to customize the type of V-nail to be used depending on the user's needs.

Each has a value stamped on it which corresponds to the height of the V-nail it can hold.

There is no need to switch over the nailing head.

The magazine translates automatically, punctually supplying the V-nail of the correct size depending on the program being executed by the PLC.

The V-nails in each magazine are held in position by the relative

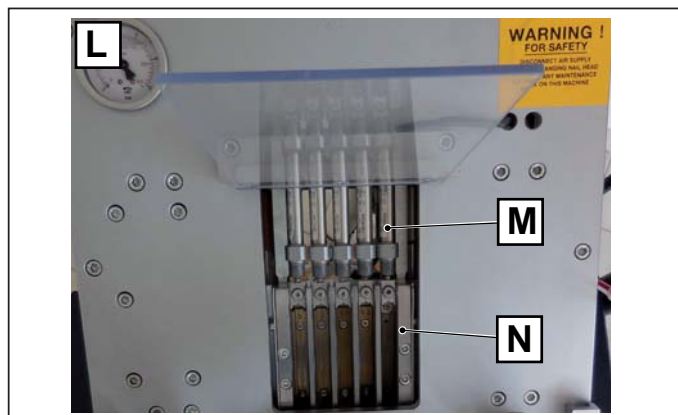

V-nail pusher device (M).

Configuration is performed by inserting special calibrated pressors (O) in each single magazine channel.



## **VERTICAL CLAMP UNIT OF THE MOULDINGS**

### **Vertical clamp unit with double hydraulic stopper**

This unit has been designed to immobilize the mouldings and counteract the opposing force applied by nailing, consequently it is important to position the stoppers in line with the direction of the nailing head; if this is not the case the V-nails may not be inserted completely if the mouldings lift slightly.

The double hydraulic stopper is basically made up of two actuators (B) filled with hydraulic fluid, connected by a hydraulic line (A) fitted onto a connector on top of each actuator.

By applying pressure onto the cylinder stem, fluid is pumped into the chamber of the other cylinder causing its stem to move forward, this is useful for achieving correct alignment of the stoppers, even when the mouldings have uneven surfaces.

This structure is fitted with a number of adjustments to be made when the program or moulding profile is changed, before nailing is executed. For this procedure please refer to the heading MECHANICAL ADJUSTMENTS.

If you wish to use only one stopper, for example on narrow frames, it is possible to block the stem using the special handle (E, H).

The vertical clamp unit is made up of the following main parts:

- A. hydraulic connection line for the fluid flow
- B. hydraulic cylinders
- C. handle for installation of the unit on the support
- D. handle for locking cylinder forward/back movement
- E. handle for locking the cylinder stem
- F. screw for locking cylinder up/down movement (one on each cylinder)
- G. rear stopper
- H. handle for locking the cylinder stem
- I. handle for locking cylinder forward/back movement
- L. front stopper

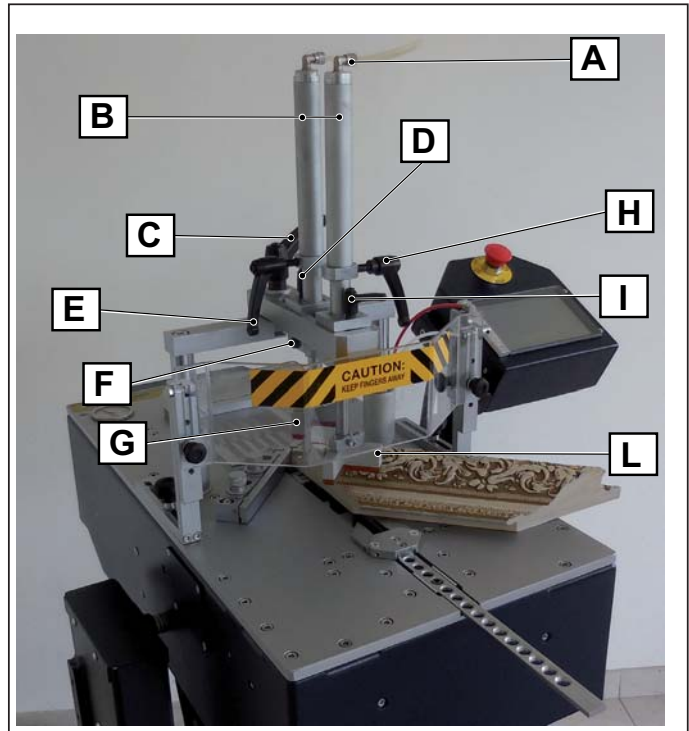

### **Single stopper unit**

The unit is made up of a mechanical stopper in vulcolan (O), located at the base of the punched rod (M), which can be positioned at various heights, depending on the measurements of the frame being handled, and translated in the direction of motion of the nailing unit by means of the fork support (S). The unit is supported by a crosspiece (Q) secured to 2 pneumatic pistons which the operator uses to control the vertical movement.

The mechanical stopper can be replaced with a support for magnetic stoppers.

The single vertical clamp unit is made up of the following main parts:

- M. punched rod which allows the operator to position the stopper at various heights based on the various frame profiles
- N. screw for fixing and quickly changing the stopper
- O. mechanical Vulcolan stopper
- P. Click knob
- Q. rod support arm
- R. stems activated vertically by the pneumatic actuator
- S. adjustable punched rod support for adjusting the position of the stopper along the stroke of the nailer unit.

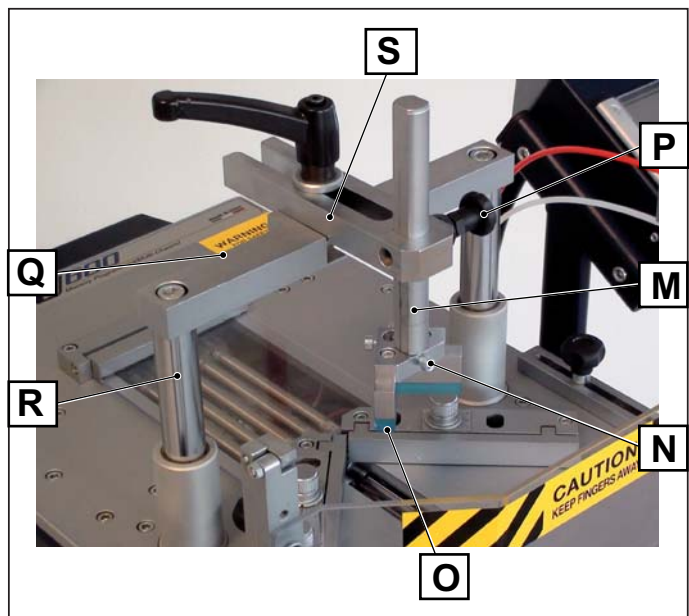



### Alignment guides

Installed on the working bench, these guide provide an adjustable rest which can be adapted to match the frame profile and compensate for the narrow cutting tolerances on the mouldings thanks to the adjustment knobs (A, B). Furthermore, thanks to the holes on the working bench (E), they can be fixed in different positions for creating 90° corners (4-sided frames), 120° corners (6-sided frames) and 135° (8-sided frames).

The alignment fences are made up of the following main parts:

- A. Slant adjustment knob for left-hand fence (D);
- B. slant adjustment knob for right-hand fence (D);
- C. fence body;
- D. adjustable fence surface
- E. holes on the working bench for fixing the fences at different angles 120°/135°;
- F. guide angle fine adjustment knob

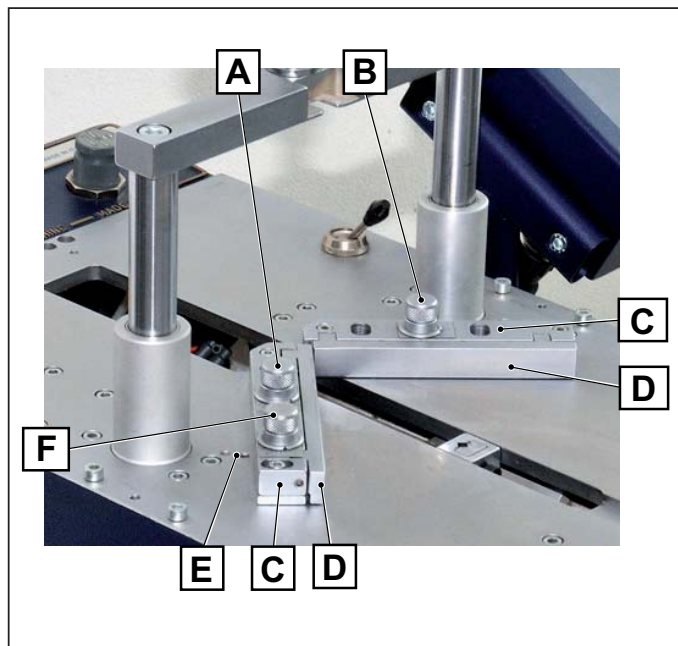

### Horizontal blocking (rod clamp)

The rod clamp is a horizontal blocking element which, activated pneumatically, blocks the parts to be joined up against the fences. The rod clamp is made up of:

- G. two jaws (one mobile and one fixed);
- H. knob for securing the rod to the actuator installed below the working bench;
- I. holes on the rod so that it can be adjusted to meet the width of the mouldings.

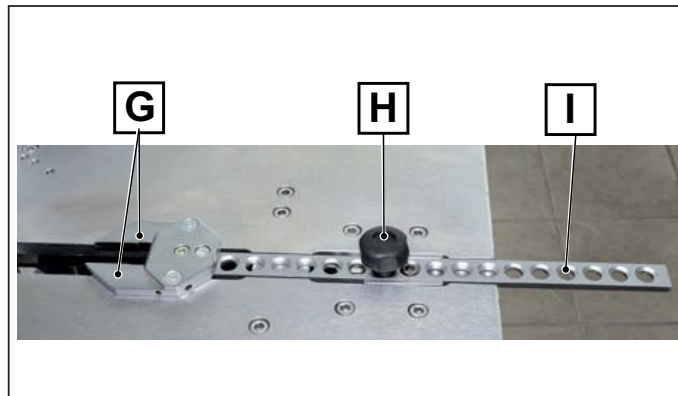

### Nailing head

The nailing head ensures precision insertion of the V-nails in the frame. There are two types of nailing head, the one used on the U500 machine (P), different for each typ of V-nail, and the one used on the U600 machine with magazine (L) which is for all V-nail heights.

On the U500 machine the head is marked with a number (Q) which indicates the height of the V-nails it can use. Each time a different kind of V-nail is used the head must be switched accordingly. Usually the machine is supplied with three different nailing heads for use with the most commonly used V-nails.

In the U600 machine, the nailing head does not need to be changed when different V-nails are used. It is marked with the code MC (M). The nailing head is installed on the L-block support (N) which is in line with the hammer and during the nailing action it is moved to insert the V-nails in accordance with the number and spacing entered in the program.

- L. nailing head for U600 Machine;
- M. code stamped on the U600 model
- N. L-block support
- O. head fixing screw

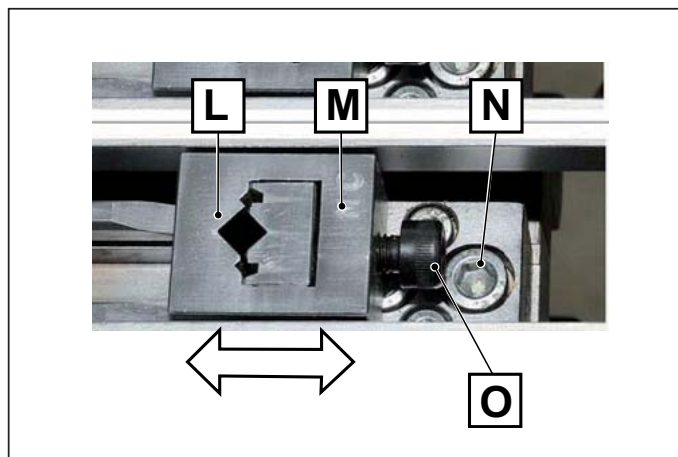

- P. nailing head for U500 Machine
- Q. this number must match the size of the V-nails being used
- R. head fixing screw

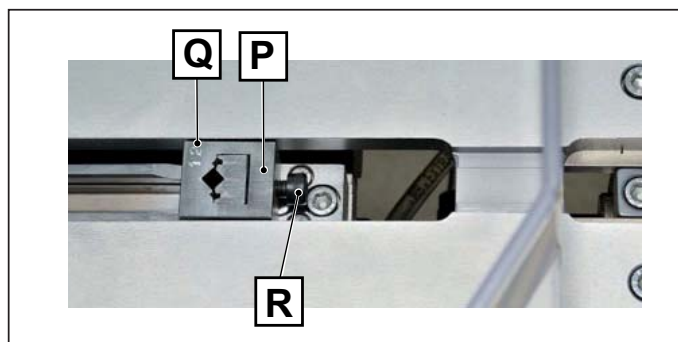

**Work surface extensions (optional)**

For joining up frames exceeding 700 mm in length the working bench needs to be increased by installing the two side extensions (A) (optional).

The extensions are fitted to the sides of the machine. They must be perfectly aligned with the working bench, see heading ASSEMBLY OF SEPARATELY SHIPPED UNITS.

- A. right extension
- B. left extension

The machine is designed to be STATIC, i.e. it must be installed on the floor or anchored to the floor or other parts of the building structure so that it remains stationary during operation.

The machine is LOADED AND UNLOADED MANUALLY:

- i. MANUAL POSITIONING OF THE MOULDINGS to be assembled on the working bench, with the fixed guards closed and locked
- ii. MANUAL REMOVAL OF THE ASSEMBLED MOULDINGS from the working bench, with the fixed guards closed and locked.

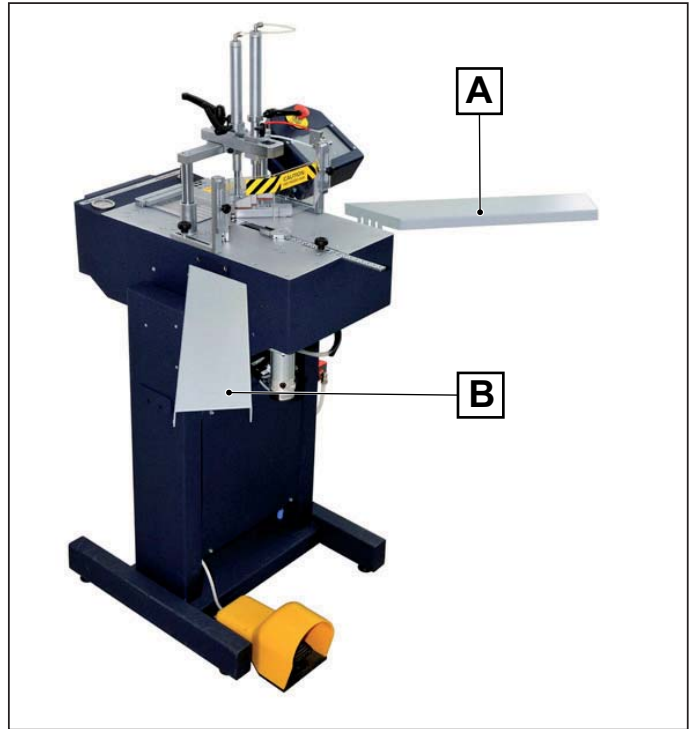

**2. INSTALLATION**

**2.1. STORAGE**

The machine, intended for indoor installation must be stored, if necessary, in well ventilated storage facilities and protected from dust. The delivered elements must remain in their original packing until the time of final installation.

All parts of the machine subject to the risk of oxidation are protected with grease and protective sprays at the time of dispatch to prevent oxidation caused by weather conditions.

In the case of prolonged inactivity the machine must be stored with all necessary precautions taken based on the location and expected storage times:

- 1. Store the machine in an enclosed place.
- 2. Protect the machine from impact and stress.
- 3. Protect the machine from humidity and excessive temperature differences (refer to the table below).
- 4. Do not allow corrosive substances to come into contact with the machine.
- 5. Check that the pack has not been damaged and that it is perfectly dry.
- 6. Specifically, if the machine is inside a shipping container, the storage area must be covered and protected against direct weather including rain, snow and hail, and it must be accessible exclusively to authorized personnel.

The machine is protected in such a way as to withstand the temperatures, humidity and vibration levels typically associated with transport and storage.

Ambient temperature	-25- +40 °C / -13 -+104°F (if the electric material has a protection rating of at least IP54) 0- +40 °C / 32 -+104°F (if the electric material has a protection rating below IP54)	Avoid places where there may be unexpected changes in temperature which could lead to the formation of condensate or freezing.
Storing temperature	-25- +55 °C / -13 -+131°F (if the electric material has a protection rating of at least IP54) 0- +55 °C / 32 -+131°F (if the electric material has a protection rating below IP54)	
Relative humidity	100% at a temperature of +25°C / 77°F (if the electric material has a protection rating of at least IP54) Lower than 50% at a temperature of +40°C / 104°F Lower than 90% at a temperature of +20°C / 68°F (if the electric material has a protection rating below IP54)	
Vibrations	5.9 m/s <sup>2</sup> (0.6G) or higher	
Atmospheric pressure	900 mbar or more	

Storage temperature is construed as a short-term value, e.g. during transportation. Condensation or freezing normally occurs in sites subject to significant temperature excursions. Even if relative humidity in such conditions falls within the values shown in the table, locations subject to significant temperature changes should be avoided.



## 2.2. CHECKS ON RECEPTION



### NOTES

It is essential to check the packs at the time of arrival and in the precise moment in which they are received. The check is performed in two stages for each pack received to avoid misunderstandings with the shipping agent.

#### Administrative check

1. Crate number and number of packs.
2. Weight and size
3. Correspondence of information on shipping document with the material effectively delivered (description, serial number, etc). The technical data given on the machine identification plate must correspond with the date given in the technical data supplied).
4. Check correspondence between shipping document data and the order.

#### Technical check

1. Condition and intactness of packaging.
2. Check that the packaging shows no signs of visible damage caused during transport and handling operations.

All the above checks must be performed by inspection in the presence of the shipping agent's delivery person. If any damage is noted or the supply is incomplete or incorrect, inform the manufacturer's sales department immediately.



### NOTES

In relation to the above prescriptions, the manufacturer informs the user that in compliance with current international and national rulings, goods are always shipped at the risk and responsibility of the purchaser and, unless otherwise stated in writing at the time of the order confirmation, freight travels without insurance cover.

## 2.3. TRANSPORT, LIFTING AND HANDLING

Dimensions, weight and handling of individual machine parts

#### MACHINE BODY

Machine height .....	A = 1500mm - 11" 1/16
Machine width .....	B = 770mm - 6" 5/16
Machine depth .....	C = 770mm - 6" 5/16
Height of the working bench from the floor. D = 1000mm - 3" 3/8	
Weight .....	140 kg

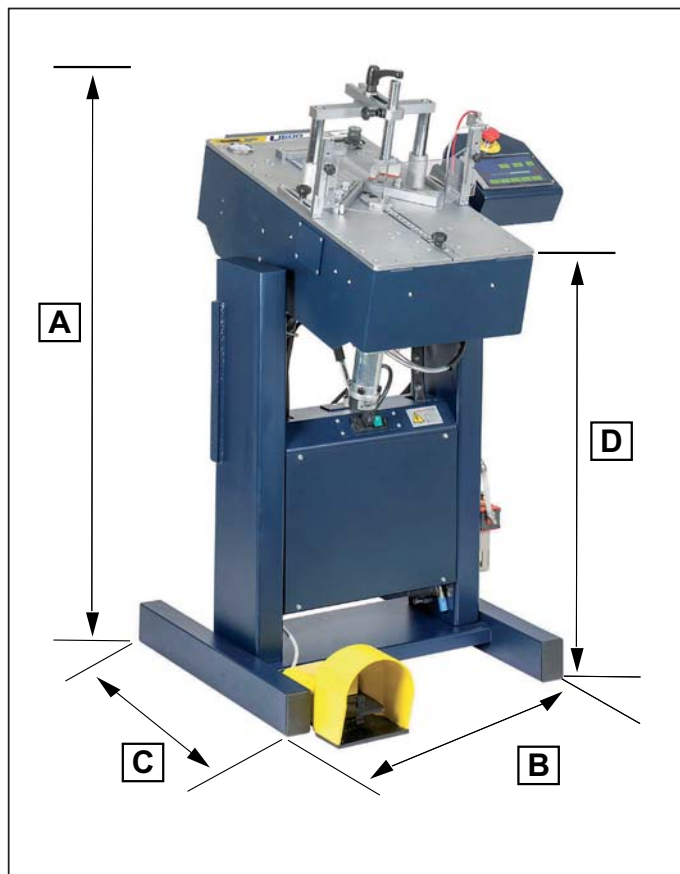

## 2.4. LIFTING AND HANDLING

### **DANGER – CAUTION**

- The machine must be transported to a position as close to the intended installation site as possible. Said site must be checked beforehand to obtain information about the necessary clearances and dimensions, including the essential space required for installation procedures.
- It is strictly prohibited to lift loads over people. If persons are present in the area, lower the load and ensure everyone moves out of the way.

### Lifting FROM BELOW

The operations to lift and handle the machine must be carried out using either a forklift truck or a pallet jack, making sure that the forks of the chosen equipment are inserted correctly under the packaging or machine structure. Make sure the load is evenly balanced.



The forks on the equipment used to lift and handle the machine must be in good, undamaged condition and be at least 1500 mm long.

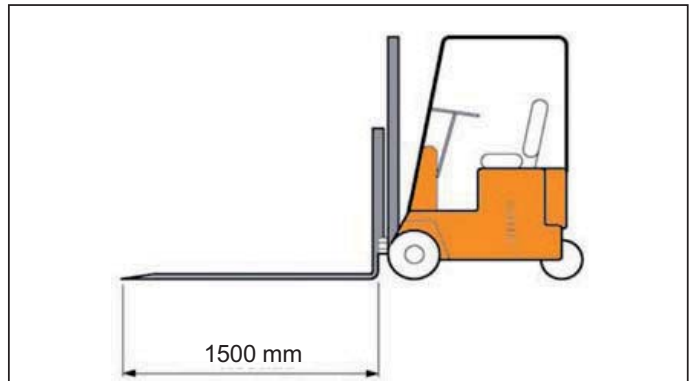

When the machine is packaged on a pallet it must be moved by a forklift.

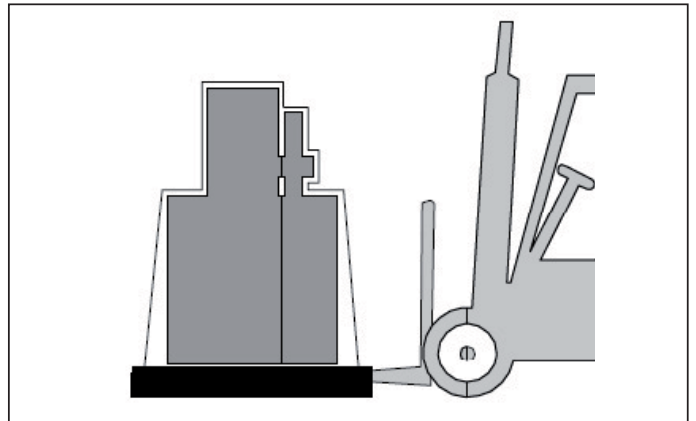

When the machine is unpacked it can be moved on a two-wheel trolley.



## 2.5. REMOVING THE PACKAGING

### Description of the packaging

The machine may be shipped in a container or on a lorry. In both cases the same type of packing is envisaged which is suitable for guaranteeing the good condition and proper preservation of the machine during transport up to the time of delivery to the customer.

For correct balancing of the weight, pick up the machine using forklift equipment, inserting the forks in the points indicated by the arrows in the figure. Before proceeding to move the machine, make sure that the weight of the machine indicated on the packaging falls within the maximum hoisting capacity of the chosen lifting equipment.

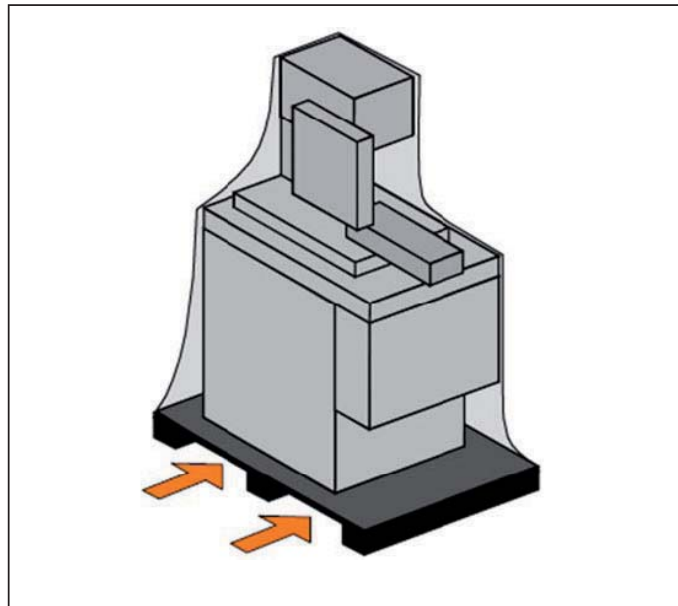

**! DANGER – CAUTION**  
*Do not rig the machine up with belts for handling operations.*

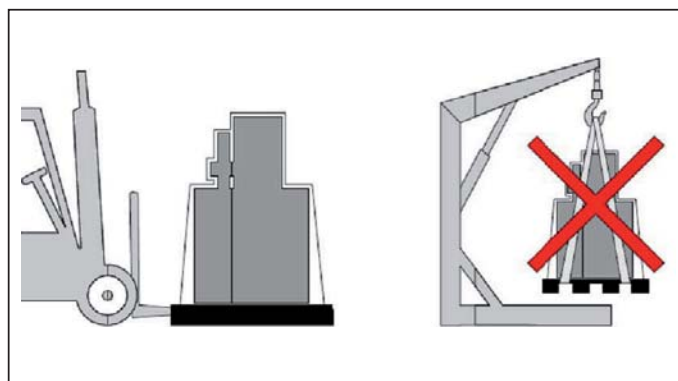

When storing the machine, never stack two machines packed on a pallet with shrink wrap.

The various packing materials must be disposed of in compliance with the relative legislation in force. Seek advice from the delegated authorities and/or the assistance of specialist companies authorised to dispose of pollutant or recyclable waste products.

**! DANGER – CAUTION**  
*Warning – pollution hazard: do not dispose of the packing material in the environment; retain it for future transport uses or consign it to a recycling company. Evaluation and management of the packing materials in terms of biological compatibility are the duty and responsibility of the user.*

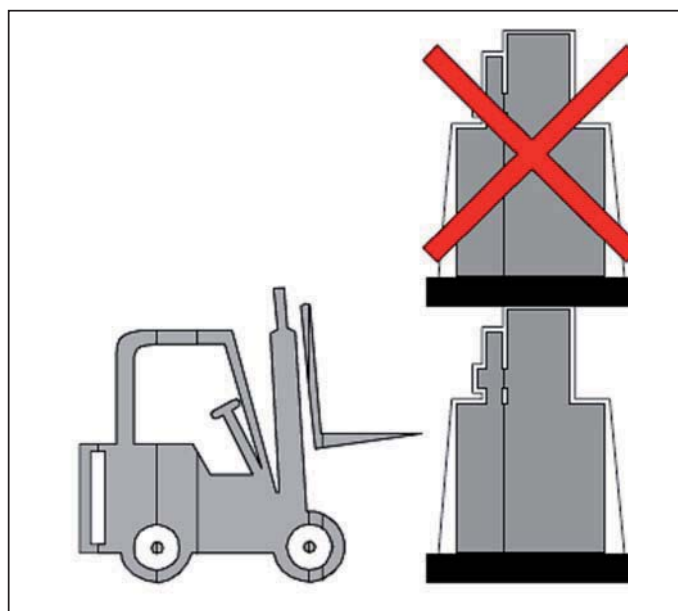

### 3. PRELIMINARY PREPARATION AND ADJUSTMENT PROCEDURES

#### 3.1. POSITIONING

##### Suitability of the floor – supporting surface

The machine must be positioned on a solid, reinforced concrete foundation.

The floor must have an adequate load bearing capacity to support the weight of the machine. The floor must be designed and prepared by the user.

##### Preparation on site

The machine layout is provided as an attachment to this manual. It is complete with the necessary data for positioning on the factory floor. THE PLACE IN WHICH THE MACHINE IS USED must be clean and free of obstacles (see figure).

TO ALLOW FOR EASY REMOVAL OF THE MACHINE FOR MAINTENANCE it must be positioned in a place having the surface dimensions indicated in the figure.

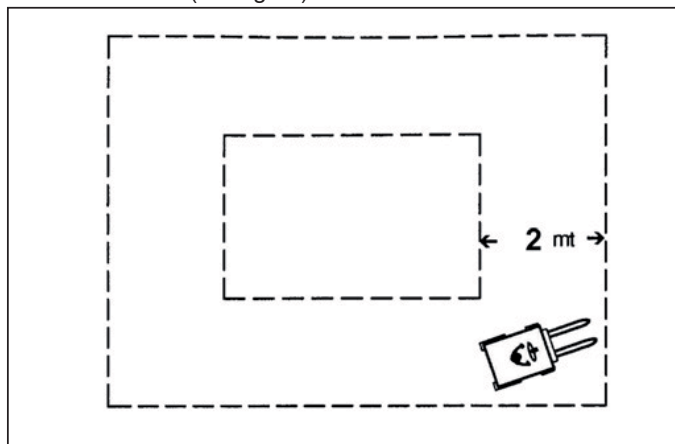

#### 3.2. LEVELLING THE MACHINE

Stability of the machine is designed in such a way that, in the specified conditions of operation, it can be used without risks of overturning, falling, or uncontrolled displacement.

In order to avoid mechanical stress during normal use of the machine and undue strain to the structure, the machine must be stabilised during lifting operations.

The machine has been designed and built to stand on its adjustable feet.

The methods and safety precautions to adopt to ensure stability of the machine must be implemented/observed whenever the machine is positioned, in compliance with the instructions given in this instruction manual.

- Using a suitable wrench install the 4 support feet (A) in the prearranged points on the base (B).
- Level the machine by adjusting the 4 support feet (A).
- To adjust the feet, tilt the machine slightly, with the aid of a second person to facilitate this operation, and then manually turn the rubber foot (C).

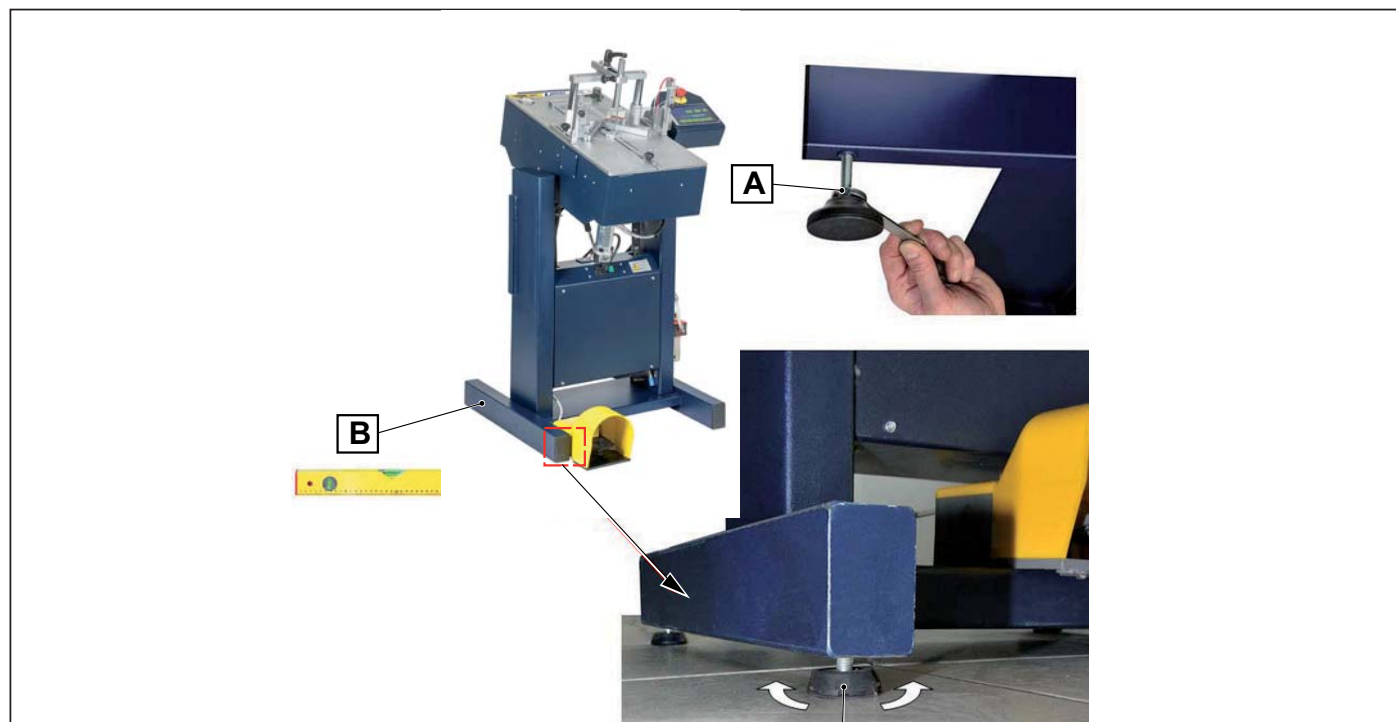

### 3.3. ASSEMBLY OF SEPARATELY SHIPPED UNITS



#### **DANGER – CAUTION**

*All assembly activities concerning machine units supplied separately, include highly delicate operations which call for significant experience. Consequently they must be carried out exclusively by personnel appointed directly by the manufacturer or authorised by the same and, in any case, under the manufacturer's responsibility. These activities are therefore the sole responsibility of the machine manufacturer's personnel.*

#### Installation of working bench extensions (optional)

The working bench extensions are optional and may be requested from the manufacturer.

Their installation requires precise alignment between the working bench and the extensions so that the lower surface of the mouldings rest fully on the entire support surface when the double stopper presses down on the ends of the mouldings.

To install the extensions proceed as follows:

1. Unscrew the grub screws located on the left- and right-hand sides of the machine.
2. Place the right and left extensions alongside the machine accordingly.
3. Insert the fixing screws and align the extensions. Finally, tighten the screws.

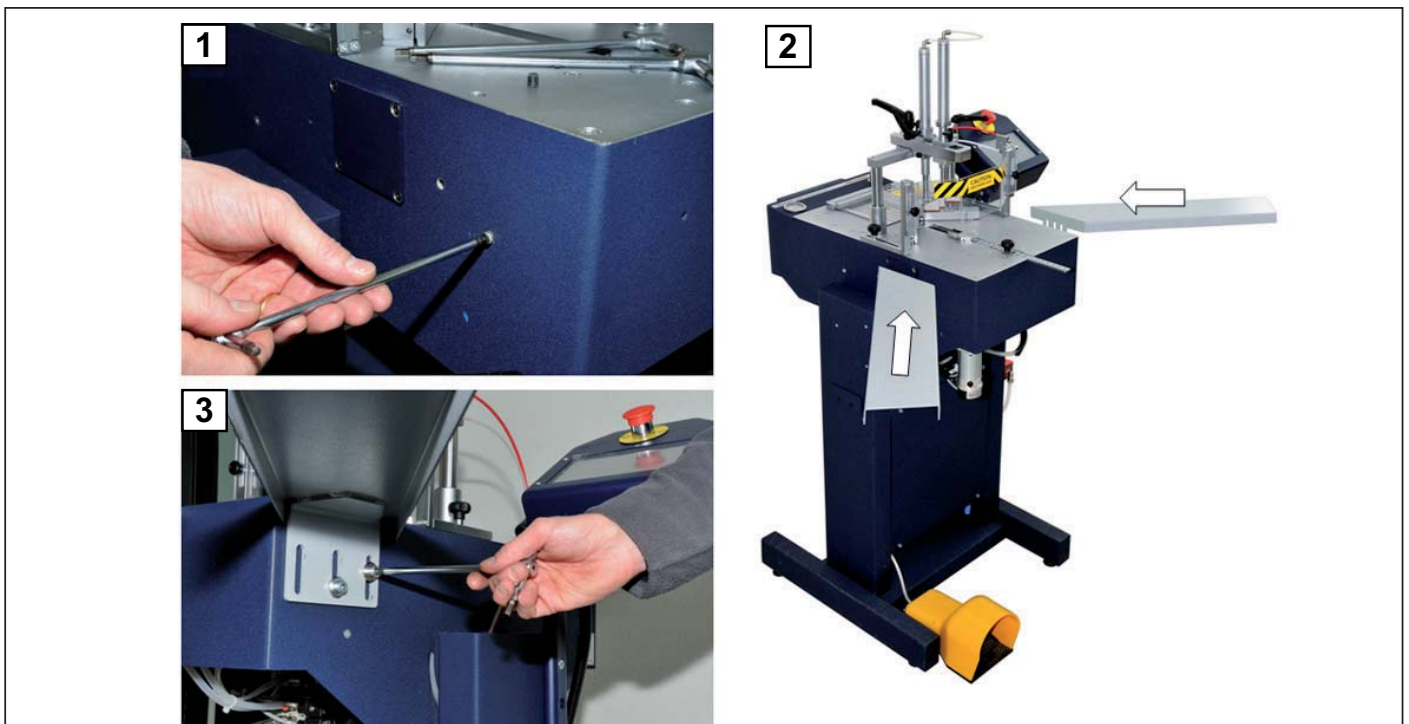

#### Installation of the control console

If for any reasons related to shipment requirements the machine is supplied with this device packed separately, follow the instructions provided below to install the control console and touch screen display.



#### **NOTES:**

*Even though installation instructions remain the same, the images of the control console provided are purely indicative as the configuration may vary depending on specific requirements or technical updates.*

1. Install the console on the special support using the screws provided. The control console can be mounted on either side of the machine, depending on operator requirements.
2. The console can be installed on the support at one of two different angles; 30° and 45°.





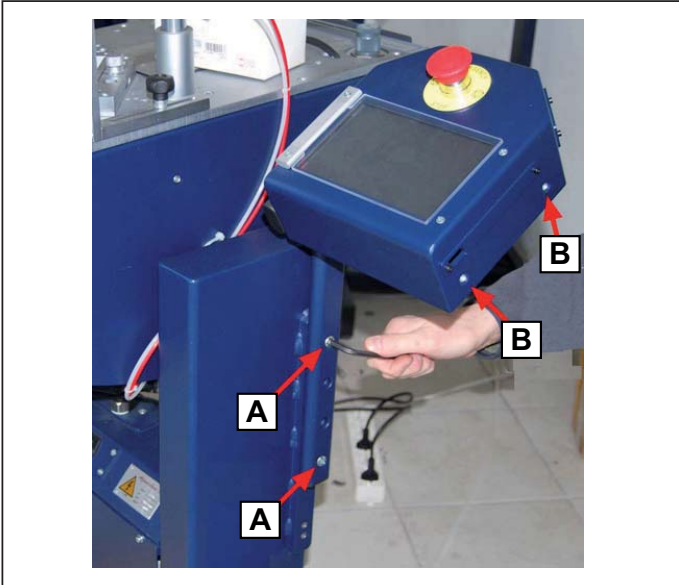

2. If the machine is supplied with the console installed on the right-hand side, remove the two screws (A) and the two screws (B) which act as plugs.



3. Remove the two screws from the special support.

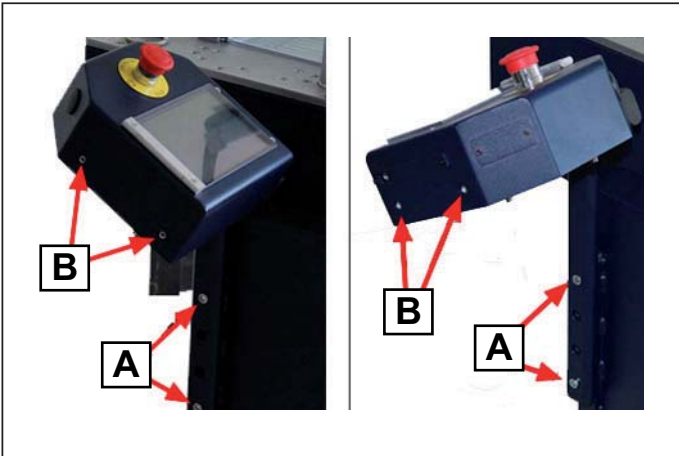

4. Insert the two screws (A). Tilt the console to meet operating requirements, as illustrated in the example, and insert the two screws (B) which act as plugs.



5. Secure the console unit to the special support at the required angle using the two screws provided.



6. Connect the machine's electric cable to the console by means of the relative circular connector.

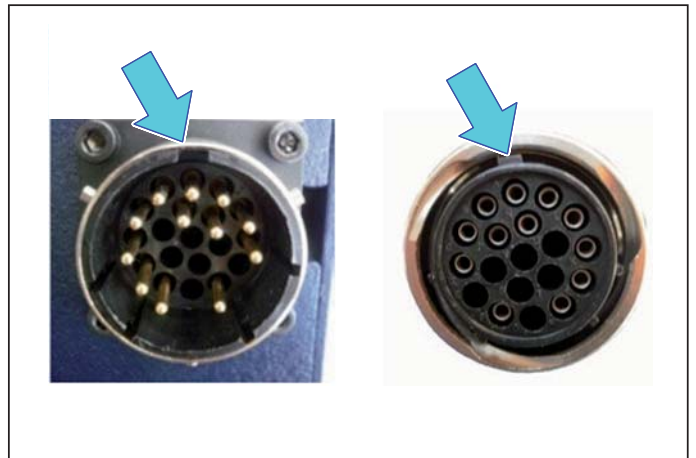

7. Match the connector pins to ensure correct insertion.



8. Do not force the connector into the socket. Once inserted, turn the ring nut clockwise until it is completely locked.

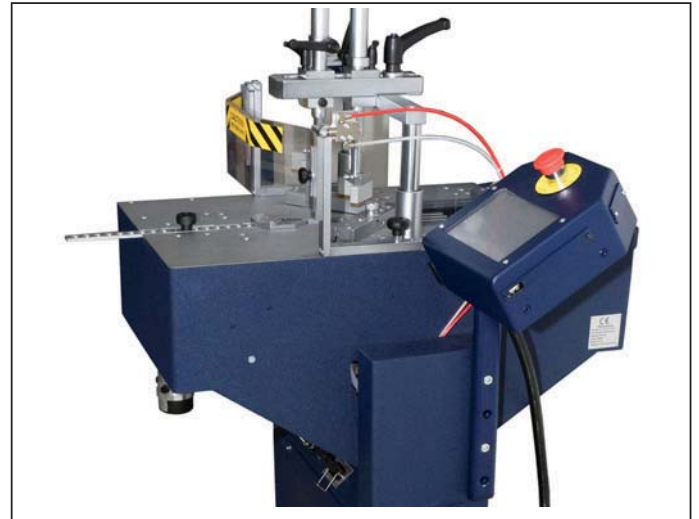

9. Connect the machine up to the power supply and proceed with machine testing.



**NOTES:**

For further information, please refer to "ANNEX A".

### 3.4. POWER SUPPLIES

#### 3.4.1. Electricity supply

Hook-up of the electrical power supply must comply with all of the relevant legislation in force in the country of machine use. The electrical power supply must be maintained in compliance with the following technical prescriptions:

1. The electrical enclosure power supply must be of the type and have an intensity corresponding with the specifications provided on the first page of the power circuit wiring diagram and those indicated in the heading "Technical Characteristics". If excessive voltage values are applied, the components may be irreparably damaged;
2. A residual current device must be installed that is coordinated with the protection circuit, in compliance with the legislation and the legislative and regulatory provisions in force in the country of installation.
3. The electrical enclosure power supply, taking into account the fact that the electrical enclosure is construed as an electrical device or component in relation to the power supply network, in the context of the protection against indirect contact by means of automatic disconnection of the power supply, a residual current device must be installed coordinated with the protection circuit, in compliance with legislation and the legislative and regulatory provisions in force in the country of installation.
4. The electrical enclosure power supply cable outside the machine casing must be routed through the spaces prepared by the user which must be adequately protected.
5. The electrical enclosure power supply cable inside the electrical equipment enclosure must be routed through the spaces provided and adequately marked with symbol no. 5036 of IEC 60417-2, all in compliance with symbol B 3.6 of ISO 3864.



symbol no. 5036 of IEC 60417-2

6. The electrical enclosure power supply cable must have a section and characteristics that comply with the specifications given in the first page of the power circuit wiring diagram and those indicated in the heading "Technical Characteristics". Cables with a different sections may alter the short circuit current values and therefore impair the protection levels in the event of short circuit
7. The power supply conductors must be made of copper.
8. The electrical enclosure power supply cable, from the overcurrent protection device to the electrical enclosure hook-up point, must be a single length without any intermediate breaks or joins.
9. Before the electrical equipment is powered by the user, the continuity (connected and available) of the neutral conductor (N) must be guaranteed.
10. Before the electrical equipment is powered by the user, the continuity (connected and available) of the yellow and green conductor of the earth bonding circuit must be guaranteed.

WITH REGARD TO THE MINIMUM PRESCRIBED SECTIONS of the conductors arriving from the external power sources, refer to the contents of the power circuit wiring diagram and the information provided in the heading “Technical Characteristics”.

CONNECTION OF THE ELECTRICAL POWER SUPPLY must be made by inserting the connector of the cable provided into the socket found on the base panel (A).

**Location of hook-up point:**

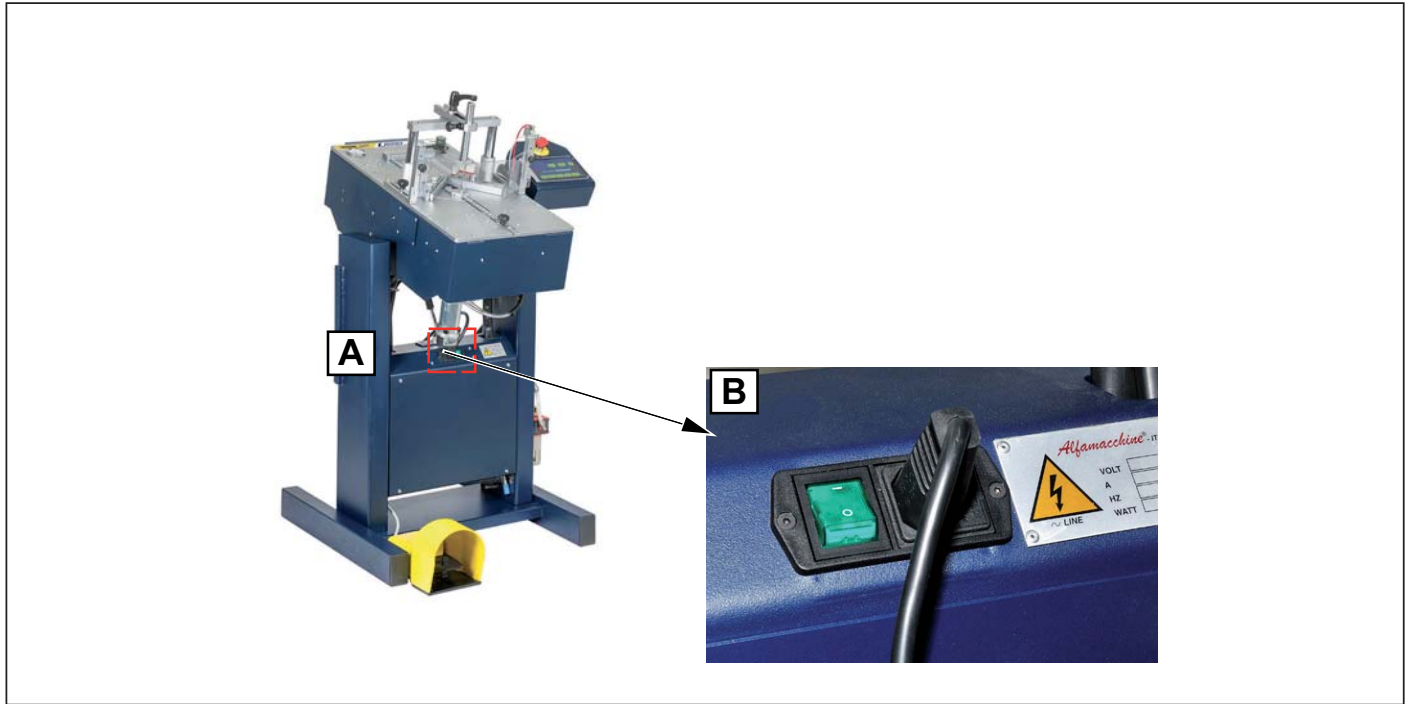

**Electrical power disconnect device**

In order to allow servicing to be carried out without the risk of electric shock or burns, a disconnect device has been installed for the electrical equipment.

The power supply disconnect device, as can be seen in the power circuit diagram supplied with the electrical equipment, is provided for the sole source of the machine power supply.

If the mains socket and the plug of the equipment are incompatible, have the socket replaced with a suitable socket by qualified maintenance personnel.

The power supply disconnect device makes it possible to separate (isolate) the machine's electrical equipment from the power supply so that servicing work can be carried out without risk of electrical shock.

The disconnect device contains two safety fuses, the characteristics of which are indicated in the wiring diagram. The fuses can only be taken out after the plug has been removed from the socket.



**0 or “disconnected”**  
electrical equipment cut off from the power supply (plug out)



**1 or “connected”**  
electrical equipment powered (plug in)



## Electrical equipment

During normal machine operation, the electrical enclosure door must be closed, locked, and kept that way. When the electrical enclosure is powered the door/s must never be opened or removed.

If the electrical equipment is put into storage for over three years, take into account the fact that the capacitors of the drives' intermediate circuits and other similar electrical components will maintain their original characteristics only if supplied with power within the first three years following the date of supply.

Before commissioning the machine, in the case of operation of an electrical enclosure which has remained in storage for such a long period of time, it is advisable to power the electrical enclosure for at least two hours in order to restore the original characteristics of the capacitors. For this purpose, supply power to the input terminals without applying the load on the output terminals. After performing this preparatory measure, the electrical equipment will be ready for installation without limitation.

### 3.4.2. Pneumatic supply

The compressed air supply must be maintained in compliance with the following technical prescriptions:

- The compressed air supply must be of the type and intensity specified on the first page of the "pneumatic diagram". If excessive pressure values are applied the components will be irreparably damaged.
- taking into account the fact that the machine's pneumatic system is construed as a component of the distribution network, in the context of protection against overpressure, a protection device must be installed coordinated with the machine's pneumatic circuit, in compliance with legislation and the legislative and regulatory provisions in force in the country of installation.
- The pneumatic system compressed air supply lines must be routed through the spaces provided by the user and must be adequately protected.
- The compressed air supply line must have a section and characteristics corresponding to the specifications shown on the first page of the "pneumatic diagram". Pipelines of different sections to those specified can alter pressure values and therefore impair correct operation of the machine.

The following units are incorporated in the compressed air inlet point:

- pressure regulator knob;
- supply pressure gauge;
- lubricant tank;
- condensate collection tank drainage point 1 and 2;
- compressed air inlet connection point with quick-fit coupler.

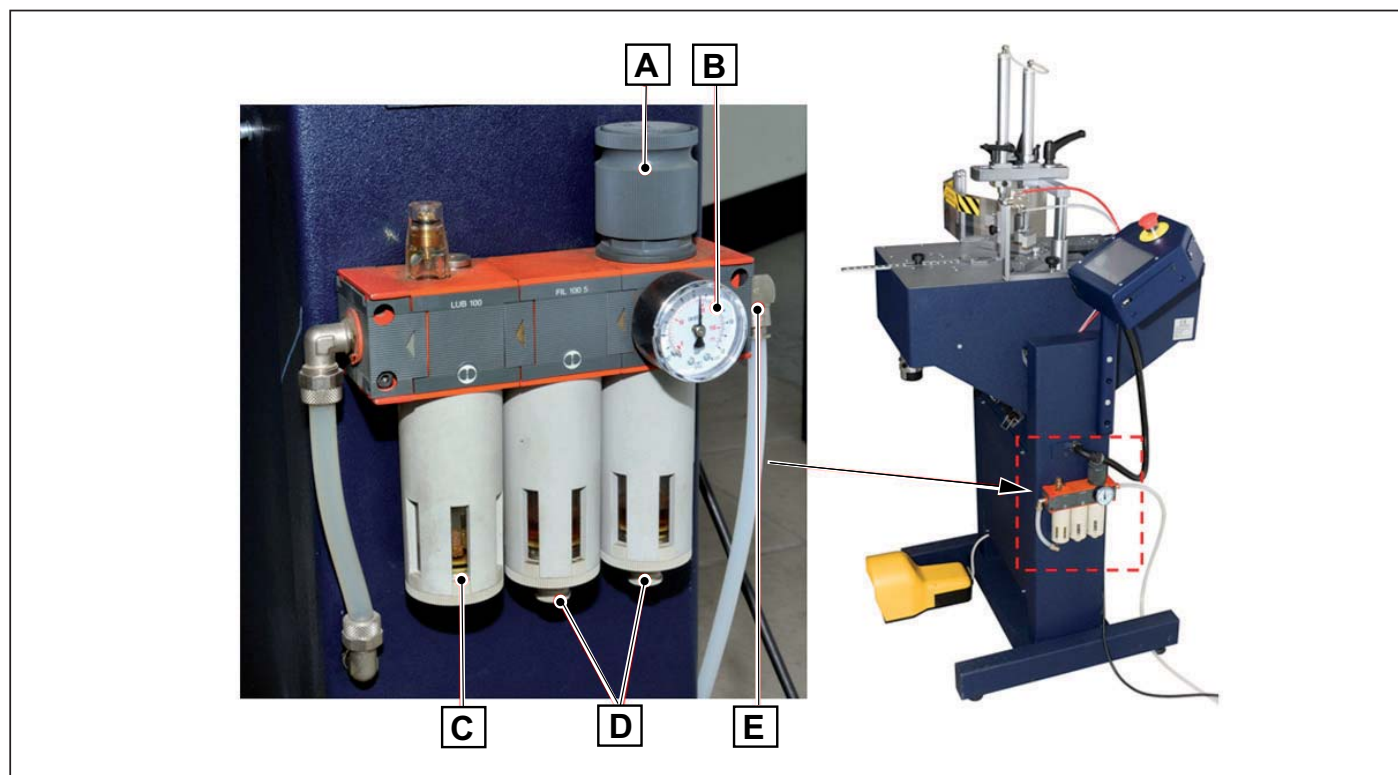

1. Before hooking up the compressed air supply to the filter unit, check that the compressed air line is of the right section for the required flow rate.
2. Make the pneumatic hook-up to the inlet of the filter/pressure reducer/lubricator assembly located inside the pneumatic casing.
3. Connect the compressed air supply line to fitting (E) and check the reading on pressure gauge (B) to ensure the value is approximately 6 bar; if this is not the case, adjust by acting on the control knob (A).

### User's compressed air production system

The compressed air production system must be designed, installed and maintained in compliance with the applicable prescriptions indicated in the safety regulations in force.

To high obtain quality compressed air, note that:

- maintenance and operation of the compressors, the auxiliary systems and the primary systems must be in compliance with the manufacturers' instructions and specifications;
- the lubricant must comply with the specifications given by the compressor manufacturer;
- the compressor or its suction line must be positioned in an area having the lowest possible level of pollution from vehicle exhausts, fumes exhaustion from industrial processes, etc.
- a filter should be installed on the compressed air line as close as possible to the user point.

#### **Air quality:**

- To obtain the best possible performance and the maximum lifetime of the pneumatic system use compressed air having a dew point between +2°C and + 10°C.
- use a separate air filter, installed as close as possible to the user point. Flush the line with compressed air before connecting it.

For correct use of compressed air, in general terms, consult the following reference standards:

- ISO 8573 – 1, this standard defines the industrial compressed air quality for general use without considering the quality of air at the compressor outlet.
- The compressed air quality level for special applications must be based on the value resulting from a large number of measurements taken during a specific time period and in clearly defined operating conditions.

For the required minimum pressure value, the nominal working pressure and the air consumption expressed as the average value for correct operation of the machine, refer to the heading "TECHNICAL CHARACTERISTICS".

### Compressed air isolation device

The compressed air isolation device, as can be seen in the "pneumatic diagram" supplied with the machine, is supplied for the sole source of the machine compressed air supply and is of the "isolating shut-off valve" type. This device is identified with the wording, visible in normal conditions of use, "PNEUMATIC SUPPLY ISOLATOR DEVICE".

The unit is located outside the machine's base.

---

## 4. INITIAL START-UP AND USE OF THE MACHINE

---



#### **DANGER - WARNING**

**THE MACHINE MUST ONLY BE OPERATED BY AUTHORISED AND DULY TRAINED PERSONNEL WITH ADEQUATE TECHNICAL EXPERIENCE.**

**MACHINE OPERATORS MUST BE AWARE OF THE FACT THAT KNOWLEDGE AND IMPLEMENTATION OF THE SAFETY RULES ARE AN INTEGRAL PART OF THEIR WORK.**

**UNQUALIFIED PERSONNEL MUST NOT BE ALLOWED ACCESS TO THE MACHINE'S OPERATING AREA WHILE IT IS IN USE.**

Before switching on the machine, operators should:

- carefully read all the technical documentation
- know which protective equipment and emergency devices are available on the machine, where they are located, and how they work

The partial removal of safety guards and warning signs is forbidden.

Unauthorised use of commercial parts and accessories belonging to safety guards and safety devices can result in malfunctions and the occurrence of hazardous situations for operators.

Before starting the production cycle, the operator must be thoroughly familiar with:

- The position, function and use of all controls.
- The position, function and use of all safety devices.
- The machine's characteristics.
- This manual, and know how to consult it.

The operator must also have been appropriately trained.



#### 4.1. WORKSTATIONS AND OPERATORS' TASKS

The machine described herein is designed to be run by 1 operator suitably trained and instructed with regard to residual risks. The operator must have the same skills, in terms of safety, as the maintenance technicians and adequate professional competence.

The normal work area of the operator and relevant tasks/assignments are:

- The manual introduction/removal of mouldings onto the working bench, with the fixed safety guards closed and locked.
- The manual loading of V-nails in the magazine, with the fixed safety guards closed and locked.
- The adjustments and tooling of the key units (head, frontal clamp, alignment fences, etc.) needed to operate the machine, using the relevant tools, with the fixed guards closed and locked.
- The manual removal of V-nails clogged in the magazine and/or nailing claw head, with the fixed safety guards closed and locked.
- Check operations (for example reading the data on the console panel and machine instrumentation). These are very simple tasks which can be carried out in total safety and clearly described in the Instruction Manual.
- Normal machine operation, i.e. stopping and starting the machine in normal conditions, and stopping it in emergency conditions.
- General monitoring of machine operation - for example checking the cleanliness of the machine, etc. In the event of a problem, the operator must not intervene, but simply call the Maintenance Service.
- Cleaning external and internal machine parts, and any other parts that may require cleaning (e.g. the upper/surrounding part of counter-rotating rollers) via the fixed safety guards, while these are closed and locked. Any cleaning of internal machine parts which requires the removal of the fixed guards must be performed by a qualified maintenance technician.

The operator is responsible for the operating process, and must control the machine by means of the command actuators located on the control panels.

Apart from normal machine operation, the operator must also start and stop the machine in normal conditions, and stop it in emergency conditions.

The operator must also carry out checks and general monitoring operations while the machine is running. In the event of a problem he/she must not intervene, but simply call the Maintenance Service.

All operations performed by the operator must be carried out with all protection devices activated, all guards in place, and all safety devices engaged in order to prevent the risk of injury to arms, legs and other body parts.

All handling operations, preparation, adjustments, installation and connection of power supplies, along with fine-tuning and operating checks, must be carried out by trained, skilled maintenance personnel.

All maintenance and control operations must be carried out by trained and skilled maintenance personnel.

All installation and hook-up operations must be carried out using suitable equipment and tools of an appropriate size (e.g. a flathead or Phillips screwdriver, hex wrenches, Allen keys, etc.), depending on the type of fasteners.

Before carrying out any installation or hook-up operation, the machine, the electrical equipment and any on-board components must be thoroughly cleaned.



#### **DANGER – CAUTION**

***Unless otherwise specified in the contract and clearly indicated in the technical specifications of this Manual, the machine is not suitable for use in environments different to those permitted and duly specified in this Manual.***

The main hazardous work areas of the machine, that may produce risks for the operator, are:

- The area beneath the double stopper, inside the magazine and near the head.
- The area inside the machine during adjustment, tooling and cleaning operations.

Schematic indications of the danger zones for machine fitters:

- A. the V-nail magazine
- B. vertical blocking;
- C. the V-Nail firing head.
- D. horizontal locking

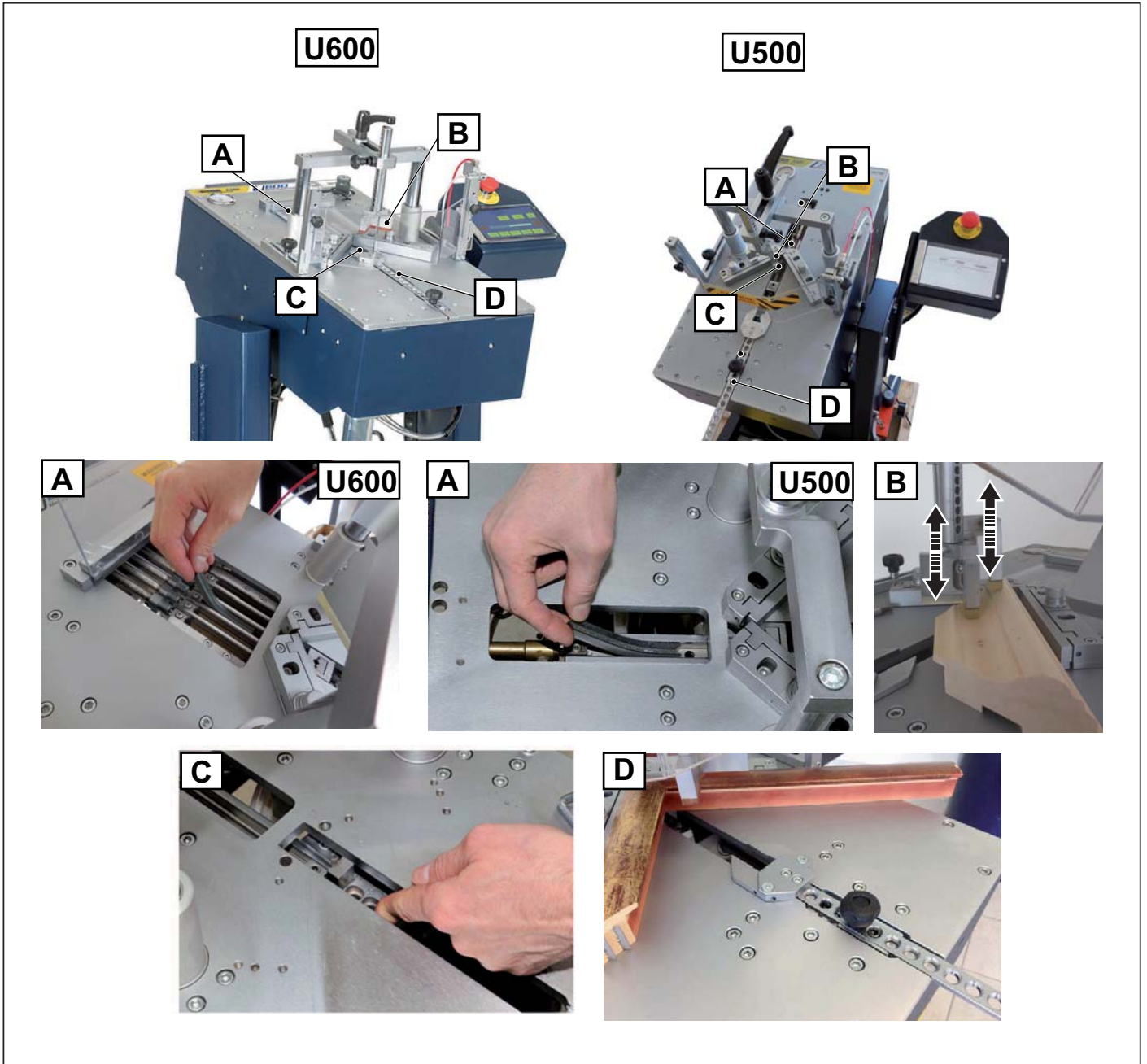

## 4.2. DESCRIPTION OF ACTUATORS, SIGNALS AND ALARMS

### 4.2.1. COMMAND AND SIGNALLING ACTUATORS

For the purpose of clear and unmistakable reference, a list of all the work and command stations (including those for emergency stops only) including their position is provided below, along with the relative references to the layout attached to the electrical diagram supplied with the machine.

#### LIST OF WORK STATIONS

- A. Control console with touch screen display.
- B. Electrical enclosure control panel with power socket and start switch.
- C. Pedal switch.

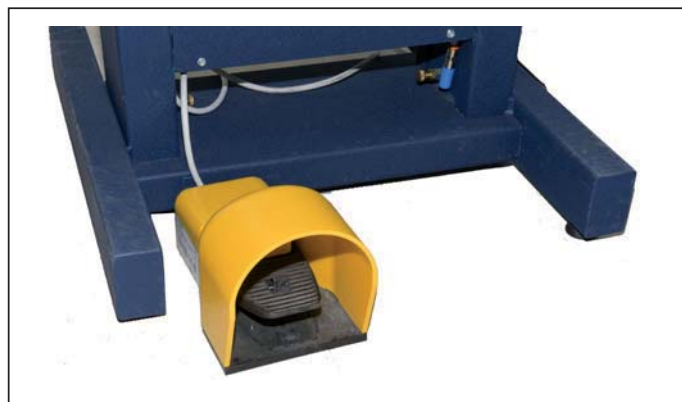
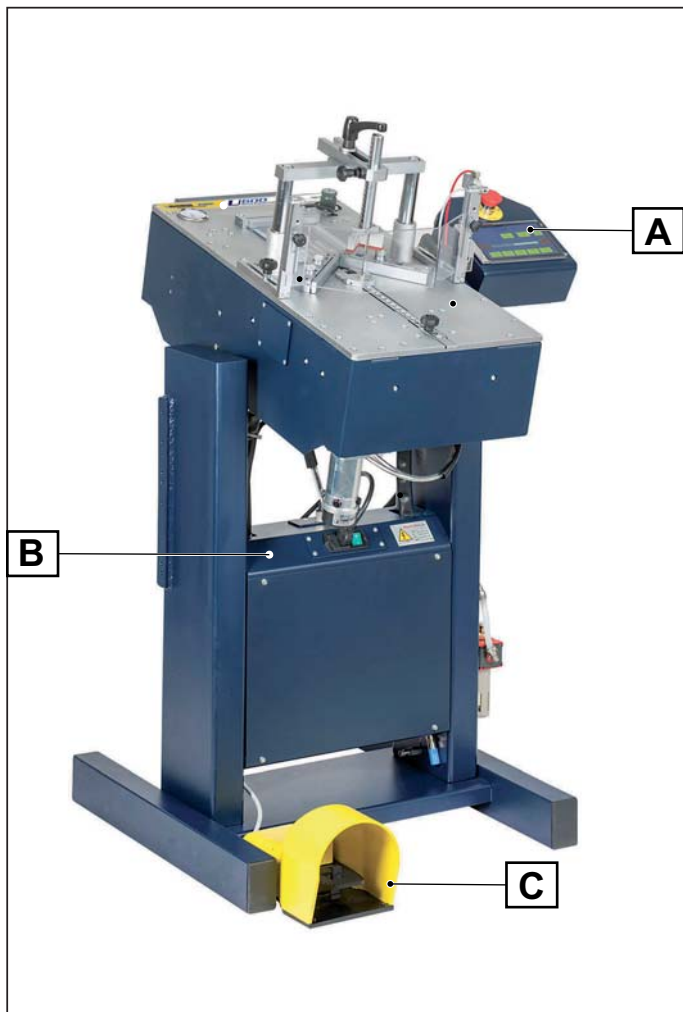

#### PEDAL SWITCH

The function of the foot-pedal switch depends on the configuration given during installation, see the heading "Customizations". Normally, pressing the pedal switch starts the machine's automatic work cycle.



#### CONTROL CONSOLE



REFERENCE COLOUR TYPE	REFERENCE - DESCRIPTION
Mushroom-head emergency stop button red 	<b>EMERGENCY STOP BUTTON</b> Control device used to activate the emergency stop function. To reactivate the possibility to reset the circuits, turn the red actuator in the direction of the arrow to release it. To restart the machine, re-enable the emergency stop button and follow the indications provided in the heading WORK CYCLE.
	<b>GUI TOUCHSCREEN</b> The operator terminal provides notifications and receives commands from the operator

The functions of the main command and information devices are described in the electrical diagram attached to this Manual.

#### 4.2.2. START-UP FUNCTIONS

All start-up functions operate only when the relevant circuit is powered .

Operation start-up is possible only if all safety devices are in place and operational. In control logic, appropriate interlocks are provided to ensure correct sequential start-ups.

The closure or reactivation of the interlocking guards and all other safeguards/interlocks does not automatically start machine movement or operation.

The actuators used to generate a start-up function or movement of the machine units are constructed and installed in such a way as to minimize the risk of inadvertent machine manoeuvres.

**! DANGER – CAUTION**  
*For all requirements, the operator shall never attempt to start the machine unless it is in its normal prescribed operative condition.*

#### START-UP FUNCTIONS

Start-up and activation of the semi-automatic work cycle:

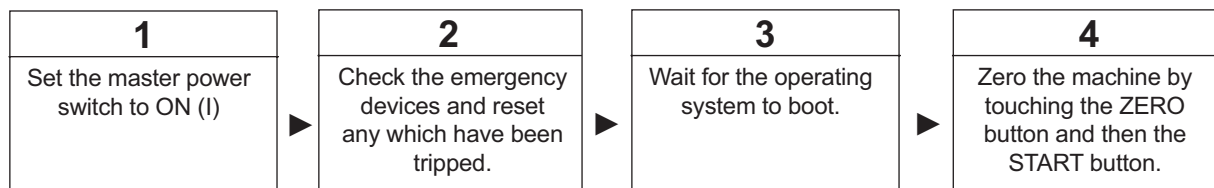

Start-up and activation in manual mode:

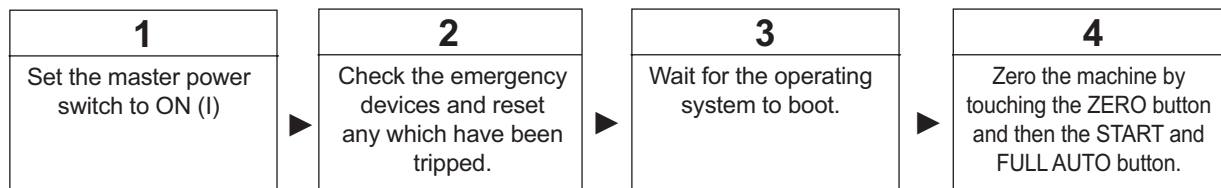

#### RESTARTING THE MACHINE AFTER AN EMERGENCY STOP

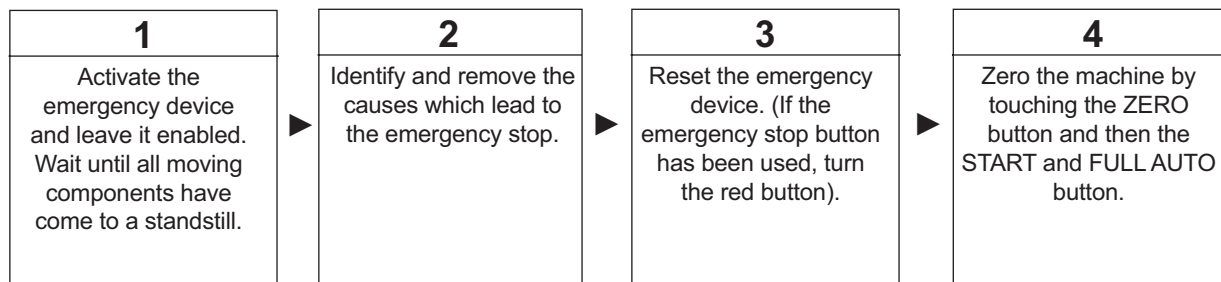

#### 4.2.3. STOP FUNCTIONS (TIMED AND SAFETY STOPS)

If any safety device (including an emergency stop device) is triggered/activated on the equipment/machine, it is necessary to:

1. Identify the cause of the stoppage.
2. Decide whether or not to set the machine to zero energy status.
3. After a stoppage caused by a power failure, inspect the equipment (the electrical panel and on-board system) to make sure there are no signs of damage to electrical equipment.
4. Contact the equipment supplier if the problem cannot be identified.
5. Once the problem has been rectified, check there are no operators, animals or objects in the machine's working area.
6. Check that no safety devices have been tampered with, deactivated, bypassed or used for purposes other than those prescribed by the manufacturer. Also check that they are reset and fully operational.
7. If the above checks give a positive result, restore the power supply to the equipment.
8. Press the reset button on the operator panel.

Do not zero/reset safety devices automatically by means of an external sequence without first checking and identifying the cause of the stoppage.

## **EMERGENCY STOP**

The emergency stop actuator is a red mushroom-head button on a yellow background. This is the most immediate way to completely and safely stop the moving machine in an emergency situation.

Activating this device (i.e. pressing the button) will immediately interrupt any operating cycle and causes a category 1 stop (a controlled stop maintaining the power supply to the machine actuators until the machine has stopped and then cutting off the power).

The emergency stop button must not be used for normal machine stops.

The command devices for activating the emergency stop function are located on the control panel.

## **STOP DUE TO POWER FAILURE**

A machine stop caused by a power failure will cause a Category 0 stop (a stop due to the immediate interruption of power supply to the machine actuators, i.e. an uncontrolled stop).

If the machine stops due to momentary or prolonged lack of power, all products/materials that were being processed must be removed before the equipment is restarted.

## **STOP DUE TO THE TRIGGERING OF THE OVERCURRENT PROTECTION DEVICES**

The overcurrent protection devices, located inside the electrical equipment casing, cause the machine to shutdown in a Category 0 stop. The intervention of one of these protection devices is caused by an overcurrent that may be an overload or a short-circuit.

## **STOP DUE TO THE MAIN CUT-OFF DEVICE**

The main disconnect devices on the external power supply generate Category 0 (zero) stops.

### **4.3. CHECKS, ADJUSTMENTS AND START-UP**

All functions/operations pertaining to operating modes must always comply with safety measures and the prescriptions for the protection against residual risks.



During normal production, the machine must only be used to process the products specified herein.

During the working cycle, it is essential to comply with safety measures and prescriptions for the protection against residual risks.

For details on the functions of each control and signalling device, refer to the layout and description of the control and signalling devices given in the electrical diagram provided as an attachment to this manual.

Please note that all users must attend a relevant training course.

### **4.4. START-UP**

<p><b>Manually CLOSE all interlocking moveable guards.</b></p>	
<p><b>Insert the power cable into the socket and press the switch to "ON/1".</b></p>	
<p>As soon as the machine is switched on, the PLC boots the operating system and the application for the graphic user interface (GUI). Touch the zero button to zero the machine and start production or programming operations.</p>	

#### **4.4.1. CHECKS ON CYCLE START-UP AND PERIODICAL INSPECTIONS.**

All regulation and adjustment operations which the operator needs to carry out to ensure correct and safe operation of the machine are indicated:

- in the specific sections on safety functions.
- in the "Maintenance" chapter
- in the specific sections regarding start-up.

Once the machine operator has ascertained that all the safety conditions indicated in this manual and described below have been duly observed, he may start the machine for ordinary production purposes.



## START-UP DIAGNOSTIC SCREEN

- A. As soon as the machine is switched on, the PLC boots the operating system and the application for the graphic user interface (GUI).
- B. During the booting phase, the following operations are performed:
1. Verification of communication with motor control electronic modules, inputs and outputs.
  2. Hardware and software check and any automatic firmware update.
  3. Verification of hardware configuration depending on selected machine model: U500 or U600.



## HOME PAGE

Once the self-diagnostic phase has been completed, the home page appears on the screen.

This initial display page will not appear if any alarm conditions are present, e.g. no air pressure or safety guards open.

## DESCRIPTION OF THE HOME PAGE CONTROLS

 Touch the "ZERO" button to complete the resetting sequence and go to the main page of the work program.

 Touch the "KEY" icon to access advanced, password-protected functions.

 Touch the "SERVICE" icon to access the maintenance section.

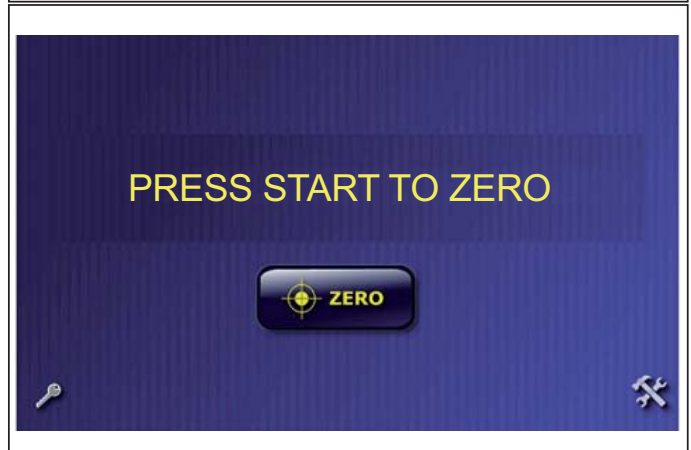

## MAIN WORK PAGE

 Touch the "ZERO" button to confirm machine reset, i.e. the automatic sequence in which the motors, head and magazine (the latter for U600 machines only), move to the mechanical stop for referencing their respective positions.

- If alarms are triggered during the resetting phase, the reset procedure will be aborted.
- Once reset has been completed, the main page appears showing the last working program in the memory.
- The machine is ready for joining, production changeover, making new programs or other activities.
- Press the pedal to adjust vertical locking and press "START" to start the stapling cycle (semi-automatic).
- To join continuously using only the pedal, switch from "Semi-Automatic" to "FULL AUTO" mode.

**Main work program**

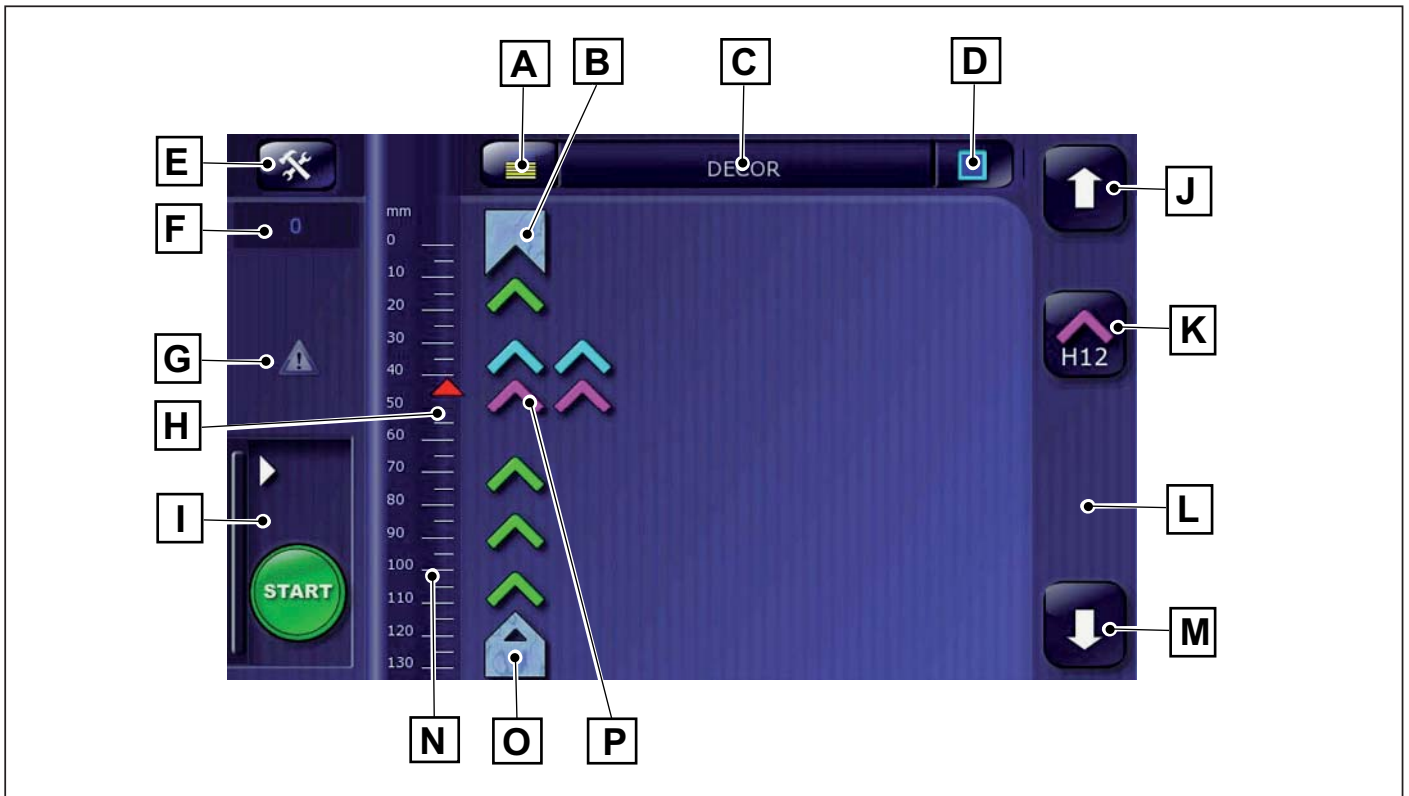

- A. Speed selection and blocking pressure
- B. Fence reference
- C. Program name
- D. Select number of frame sides
- E. Access to service and magazine pages
- F. Frame counter
- G. Alarms present
- H. Head position

- I. Operating mode
- J. Head direction
- K. V-Nail insertion and type
- L. Eliminates V-nail/initialises program
- M. Head direction
- N. Scale mm/inches
- O. Moulding max. reference dimension
- P. V-Nails positioning and type

**READY TO JOIN**

Standard operation of the machine is described below. Any operations different from those described are the result of a different configuration performed during the installation phase.

The work page shows the last stapling program;

- The different colour of the V-Nail symbol "A" indicates the relative height of the V-nail.
- The machine is immediately ready to assemble the frames.
- Press the pedal to start the cycle.
- In standard machine operation the pedal is a hold-to-run command and must therefore be pressed for the entire duration of the cycle.
- If the pedal is released before the work cycle has been completed, stapling operations will be stopped and the workpiece released.
- The stapling cycle will not start if the locking devices are not active.
- To insert the V-Nails in a certain position only, make the relative selection.

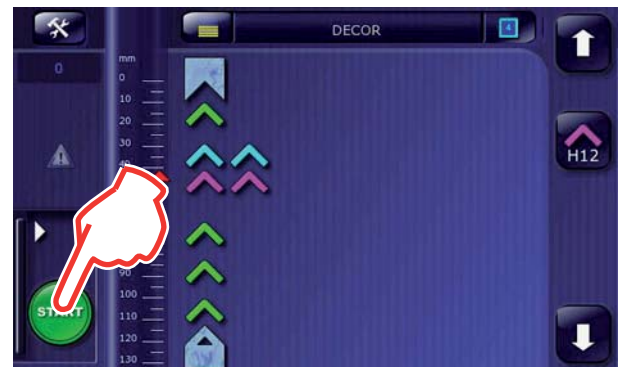

**Semi-Automatic mode:**

When entering the work program page, the machine is preset to SEMI-AUTOMATIC mode.

- Press the pedal to adjust the moulds blocking devices and check the angle of the join.
- Once angle and blocks have been set, press START in order to start the stapling cycle, keeping the pedal switch pressed.

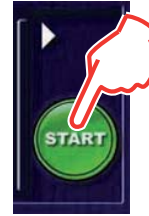
**Automatic mode:**

- Touch the arrow to hide the START button.
- The machine is now in AUTOMATIC mode.
- When the pedal is pressed the stapling cycle runs as soon as the mouldings have been blocked, without the need to activate any other manual controls.

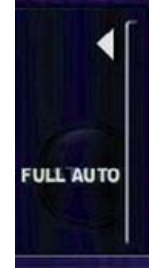

During the assembly cycle, the touch screen is disabled.

**4.4.2. PRODUCTION / PROGRAMMING PARAMETERS SETUP**

In order to achieve a well-made join some adjustments may need to be made while the machine is running:

- depending on the type and dimensions of the V-Nails,
- depending on production requirements,
- depending on the hardness and the dimensions of the materials being joined together.

A list of all the adjustment and control operations (based on the hardness and the dimensions of the materials being joined together) which the machine operator can carry out during the production cycle are indicated below.

Note: all safety measures and precautions against residual risks must be duly observed.

The steps for machine set-up, new production set-up or production changeover are outlined below.

**PROGRAM FILE MANAGEMENT**

Below you will find the procedures to:

- access the list of stored programs
- call up a program
- create a new program and store it in the memory
- create a new program from barcode
- modify a stored program

**ACCESSING THE LIST OF STORED PROGRAMS**

To access the list of programs, touch the "Program Name" field. The name of the active work program is highlighted in red.

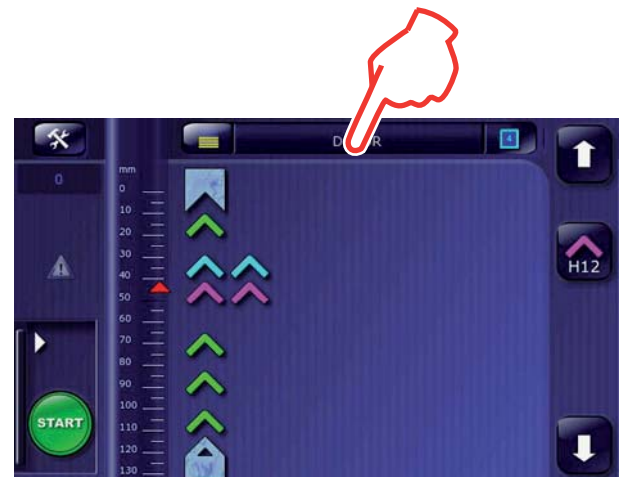

By selecting one of the programs in the list, the following options are displayed:





Change production search/select the program and confirm by pressing OK.



Reject the selection and return to the previous work program.



**Access information**



**Delete program**  
option not possible for the active program (highlighted in red).



**Block program**  
a password must be entered.



**Rename the program**  
this is the name displayed on the work page and the name available in the program search list.



**Frame counter reset**  
reset is only allowed for frames.



**Enter Barcode (via USB)**  
this is the name the search from the work page refers to. To enter the code simply read the barcode with a scanner and it will appear in the "name field" of the alphanumeric keypad. Press "OK" to confirm and memorize it.



**Stapling direction**  
- from the outside corner  
- from the inside corner



**Program copy**  
search / select a program from the list and touch the "+" button to copy it.



**Copy single program onto a USB flash drive.**  
Press on the "USB" icon to save the selected program on a flash drive.

## CALL UP A PROGRAM

Several thousand programs can be saved on the CPU board's memory.

When the cycle is not running, the work program can be changed quickly.

There are two ways to search for and save an existing work program:

1. By using a barcode scanner.
2. By searching for the name in the program list.

If you organize the archive by saving programs with their own barcode, using a scanner is the fastest search tool and can be performed from the same page as the active work program.



### Using a barcode scanner.

- Connect the scanner with a USB interface to one of the two USB ports on the control panel.
- From the main work page, read the barcode regarding the job order or the name of the program previously entered to start the search.
- If the program containing the code exists, it will immediately be uploaded and will replace the previous one.

### CAUTION!

For correct scanner configuration, adhere to the instructions provided in the barcode scanner programming manual.





abc

### Manual search from the programs list

- Touch the "Program Name" field to access the program list .
- The list of programs displays the active program name in red.
- Call up the keypad by touching the "Name" field at the bottom of the display and enter the Name or part of it in the field to start the search.
- The search procedure will start immediately, as soon as the first character has been entered, displaying all the names containing the characters entered on the keypad.
- Select and confirm the name of the program found to upload it to the work page.

### CREATE A NEW PROGRAM

It is possible to create a program for each type of moulding profile to join, depending on the hardness of the material, the size of the mouldings, the number and type of V-Nails to be inserted, etc..



Touch the "Program Name" field to access the program list .  
Call up the keypad by touching the "Search" field.

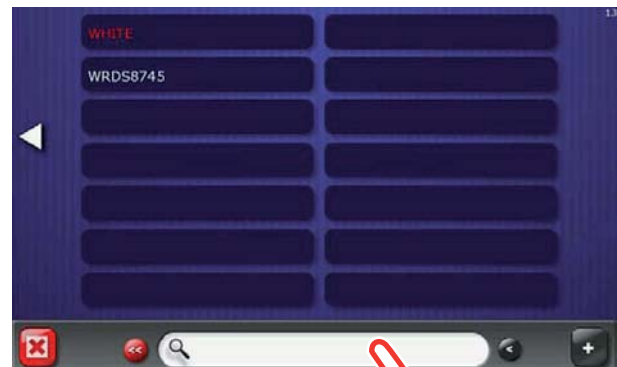

Type in the name of the program you want to create;  
(while typing, the system is in name search mode).

- Touch the "+" key to confirm the new Name entered and return to the work page to complete the program.



The newly created program is in "Auto-placement" mode and must be completed.





The “Auto-placement” system proposes V-nail arrangement and number depending on moulding dimensions:

- define moulding dimensions,
- add or remove positions,
- change V-nail type (height),
- change arrangement and number for each position,
- select the speed,
- press the pedal and assemble.

At the end, it is recommended to protect the program from subsequent modifications.

**V-nails auto-placement:**

as soon as the New Program has been created, the work page goes into “auto-placement” mode.

This mode is recognisable as the moulding maximum size and V-nail indicators are flashing.

The “Auto-placement” system proposes V-nail arrangement and number depending on maximum moulding dimensions.

Set the moulding size and determine the head position in line with the internal edge of the frame corner. To do this, proceed as follows:

1. Move the head by touching the direction arrows until you reach the desired moulding size.
2. Touch the part that indicates the current head position to set the new position using the numeric keypad.

As the head moves, the system recalculates the new positions and V-nail quantities along the assembly line.

The more accurate the size set (or acquired) for the moulding, the more accurate the proposed positioning of V-nails will be.

The proposed height of the V-nails will be the one used in the last program. To change the height, touch one of the flashing V-nails for at least 2 seconds, then select the new height from the list.

The new selected colour (V-nail height), will replace the flashing V-nail symbols.

Press the “ + ” or “ - ” keys to increase or decrease the V-nail positions.

For each amount set V-nail distance will automatically be evenly redistributed.

If the amount and type of V-nails is correct, touch the area where the V-nails are located to memorise their position.

At this point, if necessary, proceed to modify the program by acting on the single V-nail positions.

**NOTES:**  
To create a program from a barcode, see the details in “ANNEX A”.

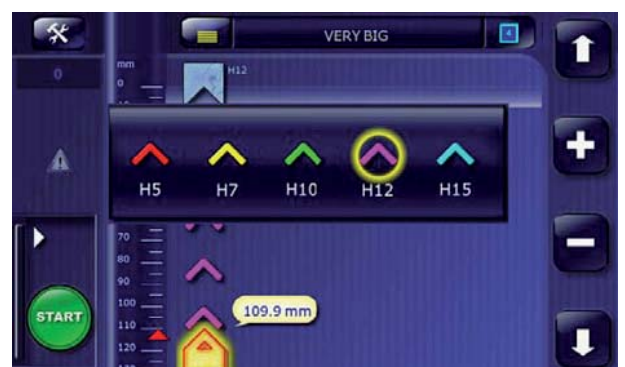
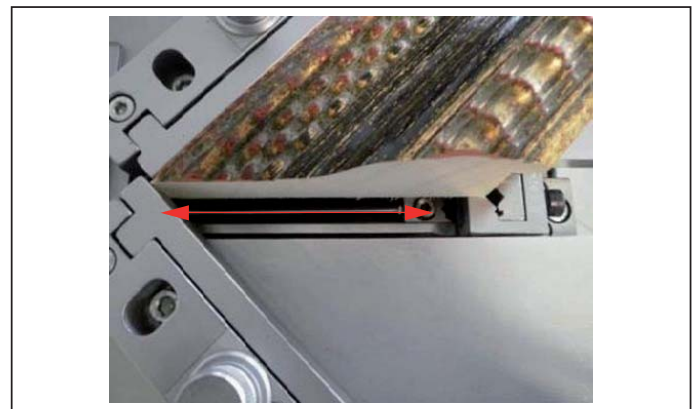

## MODIFY A PROGRAM

### Touch and select

- When the screen is touched, "Modify" mode is always active until the program has been protected.
- If the program is protected, all modifications controls are disabled.
- We recommend protecting the program to prevent unwanted modifications.
- To make modifications, first select the element you wish to alter.
- Select V-nail position to add other V-nails or to change the position itself.
- When selecting a V-nail position it will be highlighted in yellow and the relevant number will be shown.



### Eliminating the V-nail position.

- Select the position you wish to remove.
- Touch the "DELETE" button to eliminate it.



### Multiple V-nails per position

- Select the position in which you wish to add V-nails.
- Touch the "V-NAIL" button to add one V-nail.
- To insert V-nails of different heights in the same position, touch the V-nail selection/insertion icon for at least 2 seconds. Select the V-nail (colour) from the menu and then touch the "V-NAIL" icon again to enter it.

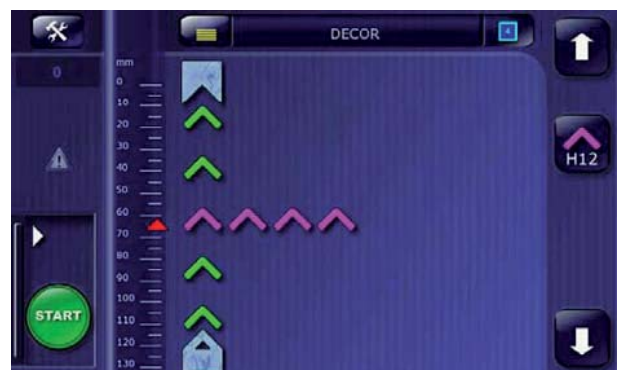

### Inserting a new position

- set the position with the numeric keypad or detect the new position of the head by touching the direction arrows.
- Touch the "V-NAIL" button to enter.
- To insert V-nails of different heights in the same position, touch the V-nail selection/insertion icon for at least 2 seconds. Select the V-nail (colour) from the menu and then touch the "V-NAIL" icon again to enter it.



### Changing the height of a V-nail

- Touch the V-nail position for at least 2 seconds and select the colour that identifies its height.
- The V-nail colour of the selected position will change.

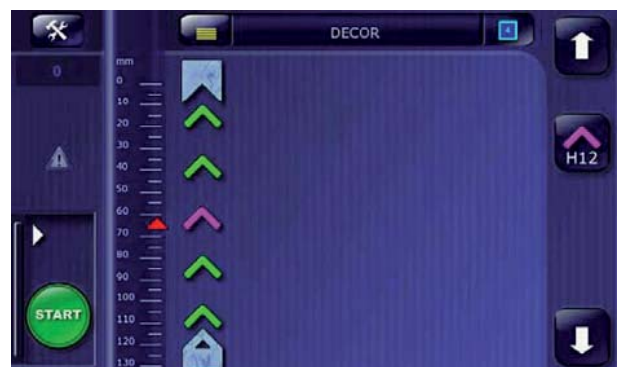

### Choosing V-nail height for a new position

- Touch the “V-NAIL” button for at least 2 seconds and select the new height.
- The “V-NAIL” button will take on the same colour that identifies the selected V-nail height.



### Speed selection

Stapling speed is defined as the activation time of the hammer which allows a V-nail and subsequent ones to be fully nailed into the material.

If the time is too short (i.e. very high speed), V-nail insertion may not be fully completed, thus causing jams in the expulsion and movement units.

Touch the “Speed selection” button to access the speed menu.



Choosing the correct speed depends on the hardness of the material (wood, plastic, MDF) and the sharpness of the V-nail used. The harder the material, the less sharp the V-nail should be and the speed must be low (red zone). If in doubt, always use a slower speed and gradually increase it until the V-nails continue to be fully inserted without any problems. An incorrect speed can cause jams, failure to insert the V-nail correctly and a poor quality join.

The list shows a scale of 9 different stapling speeds, divided into 3 different groups and colours, for easier selection according to material hardness and sharpness of the V-nails used:



**H** FAST – (#7-8-9 green zone) for Soft Wood.

**M** NORMAL – (#4-5-6 yellow zone) for Medium Wood.

**S** SLOW – (#1-2-3 red zone) for Hard Wood.





### Selecting the pressure of the clamping system, CAPS:

- touch the speed selection icon (A);
- select the clamping pressure for the mouldings by touching the value indicated on the graduated scale (B), bar/psi;
- the red dot indicates the pressure selected and stored in the program.

### Soft clamp:

- Touch "soft clamp" (C) to activate/deactivate this option;
- This function minimizes the impact of the vertical clamp unit against the surface of the moulding during the clamping operation.



### NOTES

A newly created or modified program:

- is saved in the memory if the cycle is performed at least once;
- is saved in the memory if the name appears in the programs list;
- is not saved in the memory if the machine is switched off after the program has been created or edited ("cancel").

### NOTES

For further information, please refer to "ANNEX A".

### Number of Frame sides

Touch the "Number of Sides Selection" button to access the menu for selecting the number of frame sides.

Using different shapes and colours, the menu displays the 3 frame models that can be assembled based on set-up of the alignment fences:

- 4 SIDES / 90° – (blue)**
- 6 SIDES / 120° – (red)**
- 8 SIDES / 135° – (yellow)**

Ensure that the correct number of sides is selected for the frame counter to work properly.

### CAUTION!



Once the program has been completed and tested, it is advisable to password-protect it (program block) to prevent any unwanted modifications by other users.

All changes made to the program are immediately saved.



### 4.4.3. MECHANICAL ADJUSTMENTS / MAINTENANCE

Carry out the operations detailed below using only the tools supplied with the machine.

All the adjustment and control operations which can be carried out by the machine operator during the production cycle are indicated below. Furthermore, all safety measures and precautions against residual risks must be duly observed.



**NOTES**

*In this section of the manual, the term “mechanical maintenance” does not refer strictly to interventions linked to specific maintenance operations which must be carried out exclusively by authorized maintenance personnel, but also covers interventions which the machine operator himself may perform. Said operations do however, require a certain amount of training, skill and knowledge of the machine.*

#### MAINTENANCE SERVICE



Touch the “TOOLS” button to access the maintenance controls page.

- These controls are not password-protected.
- Press the buttons to directly activate pneumatic devices (solenoid valves).
- Automatic movements of the Head or Magazine are not available as the machine still has not been reset.

#### MAINTENANCE CONTROLS PAGE

This page allows the operator to perform routine maintenance and cleaning on the machine V-Nail firing unit.



In/Out hammer activation control.



Control to open / close the V-nail pusher cylinder in the magazine (U600 model only).



Control to lock/release the V-nail magazine (U600 model only).



Press the “TOOLS” button again to return to the previous “START” page.

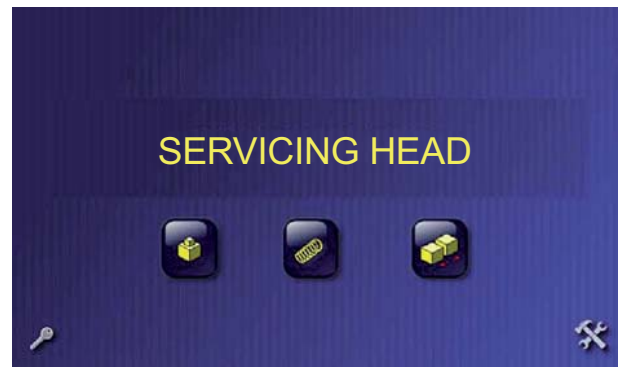

#### MAGAZINE SERVICE PAGE



In/Out hammer activation control.



Control to open / close the V-nail pusher cylinder in the magazine (U600 model only).



Control to lock/release the V-nail magazine (U600 model only).



Control to move the nailing head into the maintenance position.



Press the key button to access advanced functions (password-protected).



Head reset button.



Magazine reset button.



Selection of the sequence of blocking devices.



**NOTES**

*For further information, please refer to “ANNEX A”.*

### Filling the magazine in the U500 model

In the U500 model, single magazine loading requires manual activation of the PLV valve (A).

The V-nail detection sensor is not present, therefore the full magazine signal is given by opening the PLV valve (A).

The "Magazine Empty" alarm signal is given by the V-Nail Counter.

Insert the V-Nails as follows:

1. Act on the PLV valve (A).
2. The magazine is automatically positioned in the filling position and the V-nail pusher cylinder is opened.
3. Put the V-nails in the magazine (B), taking care to make sure the sharp part (glue-edge side) is facing upwards.
4. Turn the PLV valve back to the initial position.

### CAUTION!

Since the magazine in the U500 machine is not equipped with a V-nail presence sensor, the empty magazine signal (V-nail counter) operates based on the concept that it is filled completely (200 V-nails) every time it is opened.

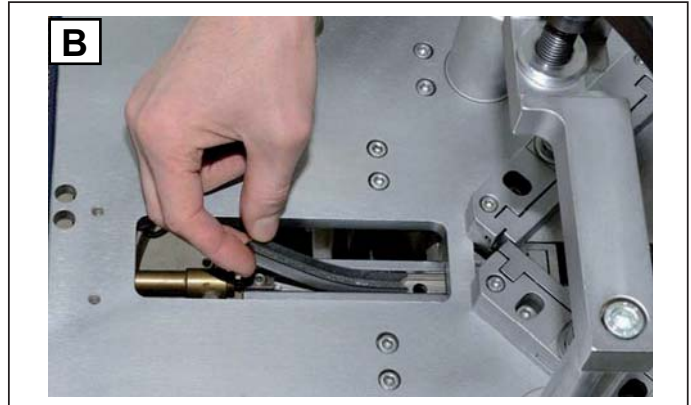

### Head replacement

#### NOTES

In the U500 model, the nailing head has to be changed over whenever a different size of V-nail is used.

In both the U600 and U500 models, the head must be replaced in the event of wear.

The measure U500 corresponding to the size of the V-nail to be used (C) 5-7-10-12-15, is stamped on the body of the U500 nailing head. To replace the head, proceed as follows:

#### NOTES

The procedure to replace the nailing head is identical for both the U600 and U500 models.

1. Unscrew the head fixing screw (D) on the L-block support using the relative tool provided.
2. Remove the head from the support.
3. Insert the new head making sure it is aligned with the hammer (E).

See the heading "HEAD ALIGNMENT"

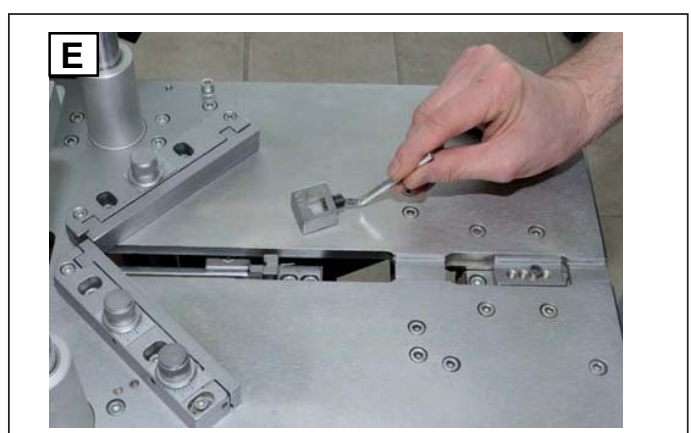
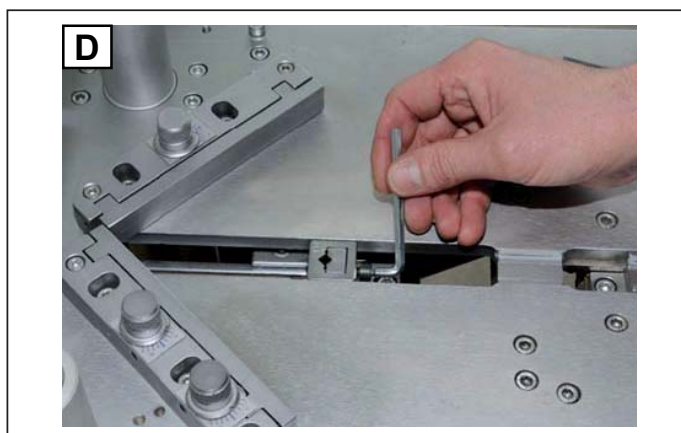
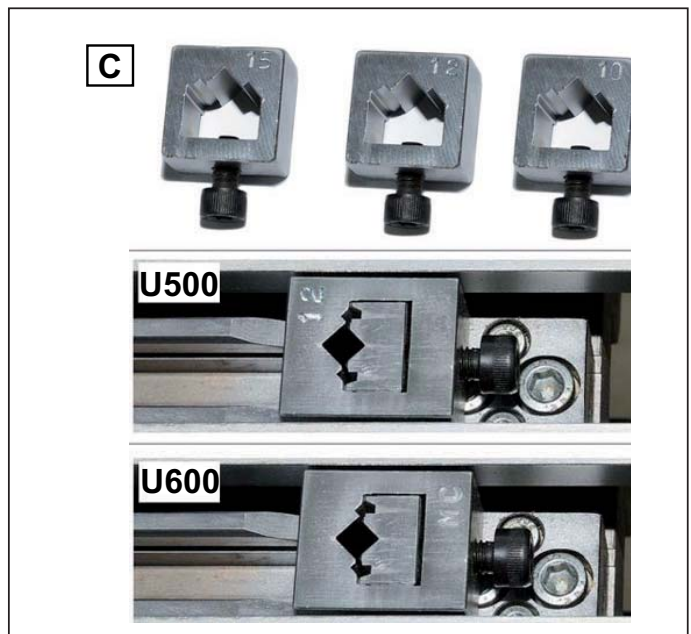

### **Filling the magazine in the U600 model**

In the U600 model, multiple magazine loading is performed by automatic positioning of the magazine.

Each magazine has a V-nail detection sensor and a “No V-Nails” alarm.

Insert the V-Nails as follows:

1. Lift the protection panel (A); the magazine automatically goes to the V-nail loading position. Opening of all the V-nail pusher cylinders is commanded (magazine open).
2. Check that the height of the V-nails matches the slot in the magazine. V-nail height is indicated on each magazine slot (B).
3. Put the V-nails in the magazine (C), making sure the sharp part (glue-edge side) is facing upwards and the top of the stick is pointing towards the pusher.
4. Close the protective panel to close all the V-nail pusher cylinders (magazine closed).

### **Customization of the configurable magazine (U600):**

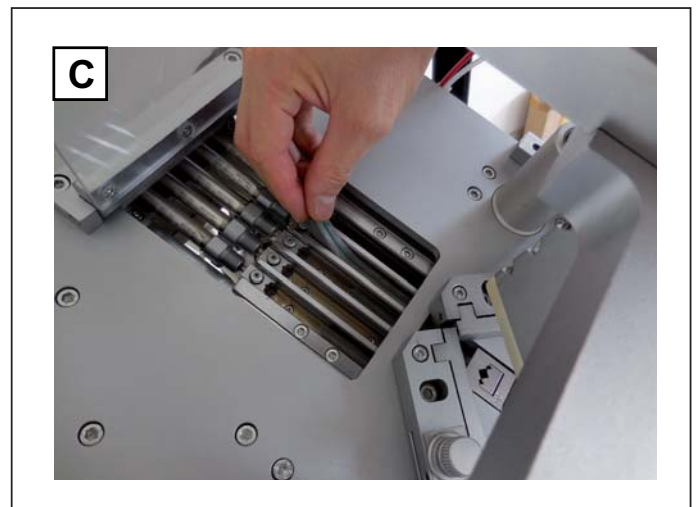
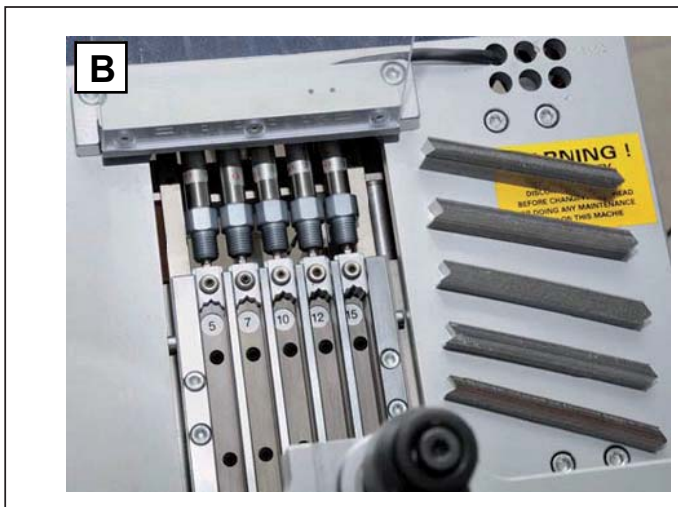
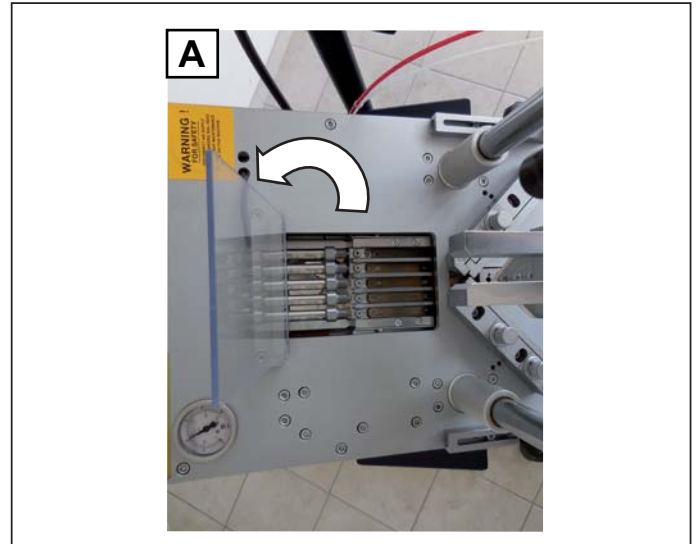

Use of the configurable magazine (U600) is only possible if the machine has been mechanically designed for that purpose.

It allows the user to customize the entire magazine assigning a V-Nail height to each of the 5 channels to meet any given preference. By interchanging the special adapters as required (D), it is possible, for example, to have a magazine with all 5 channels set to take the same height of V-nails or other combinations of heights.

The standard supply arranges the magazine with 5 channels of different height.

Configuration of the magazine is only possible if the operation is enabled by the machine setup.

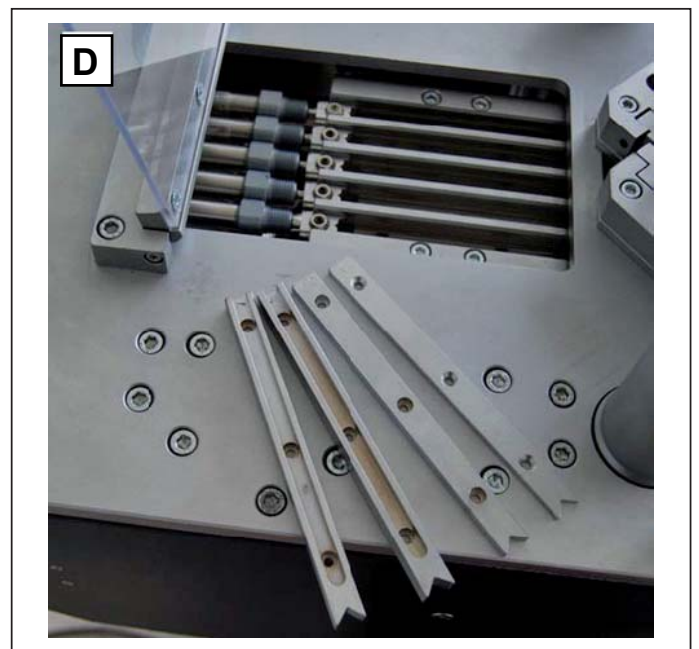

### **NOTES**

For further information, please refer to “ANNEX A”.



Replace the magazines as follows:

1. Lift the protection panel (A); the magazine automatically goes to the V-nail loading position. Opening of all the V-nail pusher cylinders is commanded (magazine open).
2. Pinpoint the channel you wish to assign a different V-nail height to and position it by touching the corresponding channel on the screen "B".
3. Remove the 3 socket head or Torx type screws (C) and remove the adapter (F) from the magazine.
4. Choose one of the marked adapters (F) depending on the V-Nail height required (5-7-10-12) and insert it in the magazine (D). Secure in place with the special screws (C).
5. Repeat the previous operations to modify the other V-nail magazines as required.
6. Once the mechanical operations to customize the magazine have been completed, access the display page (E) to program the new magazine configuration.
7. Touch the stick of the modified channel for at least 2 seconds to call up the menu for selecting the V-nail type (G).
8. Select the V-nail type (colour) for which the magazine channel has been configured.
9. Once configuration of the magazine has been completed, the display screen (E) graphically shows the new arrangement of the magazine, e.g. magazine H7 replaced by another H10 one.
10. Proceed to load with V-nails by following the instructions provided in the heading "Filling the magazine in the U600 model".
11. Once the magazine has been filled, the display page (E) indicates the presence of the replaced magazine. The example in the figure shows the presence of two H10 magazines.

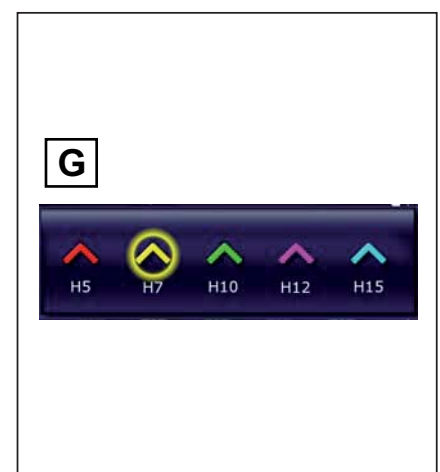
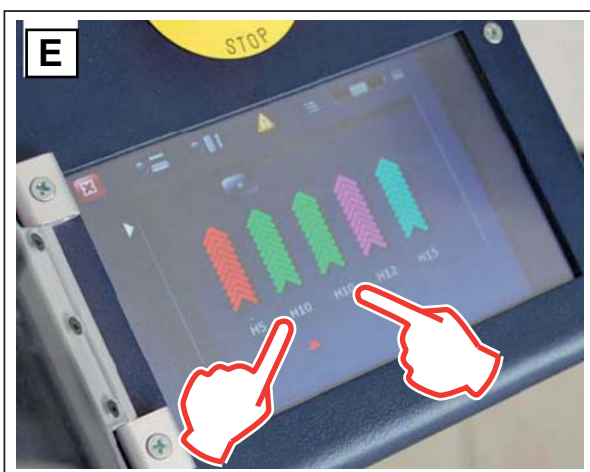
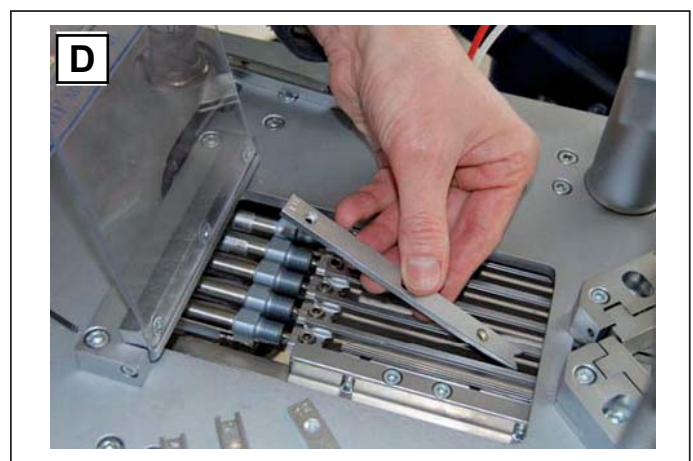
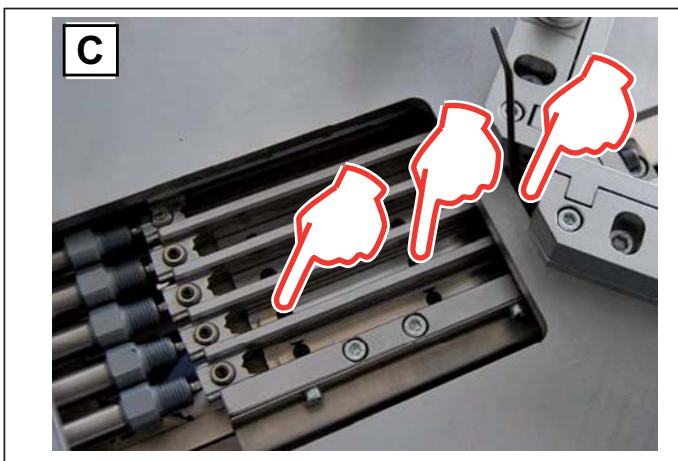
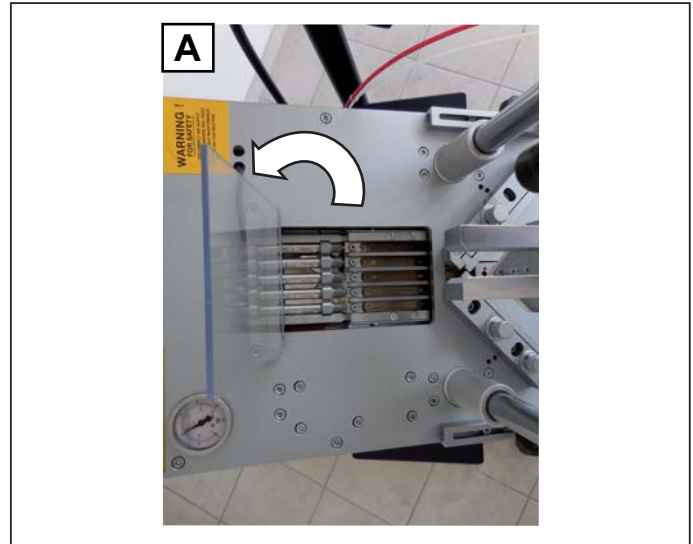



## V-Nail firing unit alignment

U500 model:

### NOTES

*This operation must be performed by an authorized maintenance mechanic or an adequately trained operator who has the right skills and adequate understanding of the machine.*

Alignment of the head with the hammer and magazine may need to be performed due to loosening caused by the operating cycle or wear on the components.

To align the head, proceed as follows:

1. Dismantle the vertical clamp unit (A).
2. Remove the head from the support, as described in the heading "Head replacement".
3. Loosen the L-block support (B).
4. Remove the L-block support (C).
5. Check that the hammer, in the high position, is aligned with the magazine (D). There must be no play between the hammer and the magazine.
6. Remove the alignment fences from the working bench (E) to free the holes below and gain access to the screws which hold the magazine in place.
7. Loosen the magazine fixing screws (F) and align the magazine with the hammer, then retighten the screws.
8. Replace the L-block support moving it up against the hammer and tighten the screws (G).
9. Replace the head by tightening the screw (H).

U600 model:

1. Alignment of the V-nail firing unit in the U600 model is the same as for the U500 model except that there is no need to take off the alignment fences (point 6) to release the magazine.
2. To move the magazine away, simply activate the relative command or disconnect the compressed air supply to the machine.
3. Slacken and adjust the L-block support only after moving the magazine away.
4. To correct the positions of the magazine channels, refer to the heading "U600 magazine adjustment".

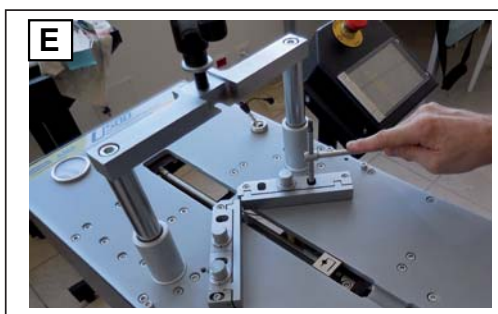

### Alignment guides adjustment

#### NOTES

*This operation must be performed by an authorized maintenance mechanic or an adequately trained operator who has the right skills and adequate understanding of the machine.*

*The alignment fences must be secured in position taking into account the linear movement of the head.*

*To check correct positioning you can ask Alfamacchine to provide you with the transparent right-angle set square on which the height is shown by a serigraph line.*

*If the alignment fences are correctly positioned, the stroke of the head runs perfectly aligned with the line of the guides.*

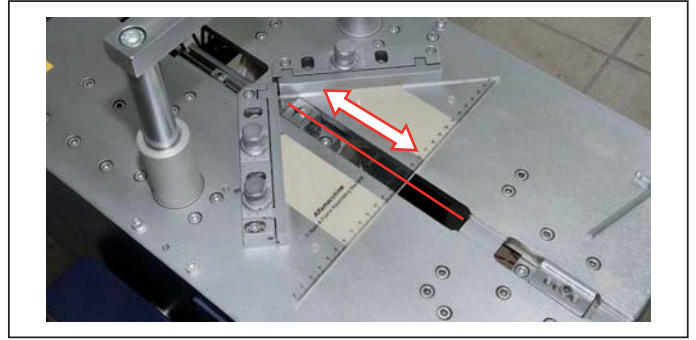

The alignment fences can be adjusted to compensate for small tolerances in the cut of the mouldings.

Move the mouldings up against the guides as indicated in figure (A), if the joint between the mouldings has any small gaps on the inside or outside of the corner, act on the knobs to close them.

To adjust the degree of the angle between the alignment fences, turn the knob on the oscillating guide as indicated in figure (B).

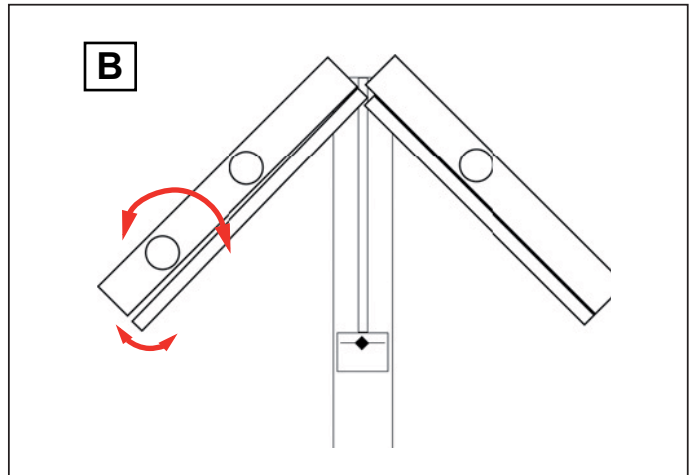
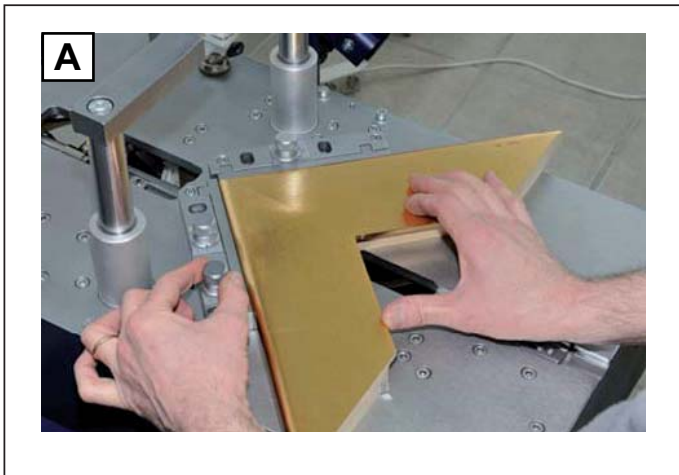

The mouldings may have an outer edge which slants slightly. To achieve better contact between these mouldings, the slant along the contact edge of the guides can be adjusted.

Turn the knobs as shown in figure (C) to achieve the correct contact edge gradient.

As well as being able to make 90° joins (4-sided frames) the machine can also be used to make 120° joins (6-sided frames) or 135° joins (8-sided frames) by positioning the alignment fences accordingly. On the working bench there are 4 holes for each alignment guide (D). One hole acts as a pivot (for the left/right guide ends) and 3 holes are used for setting the various angles.

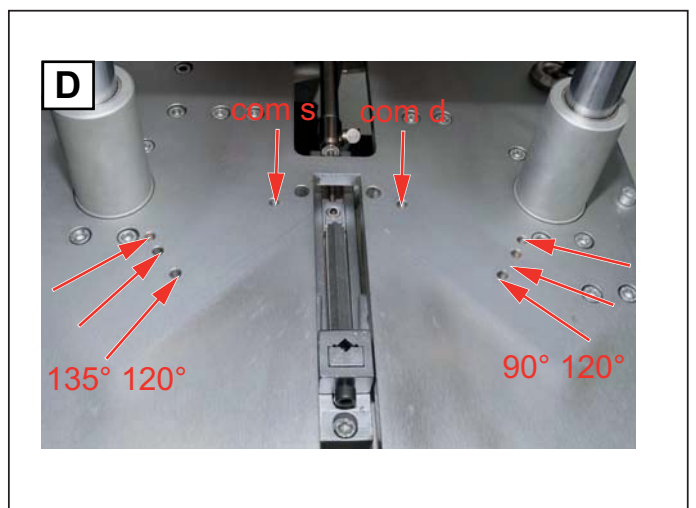
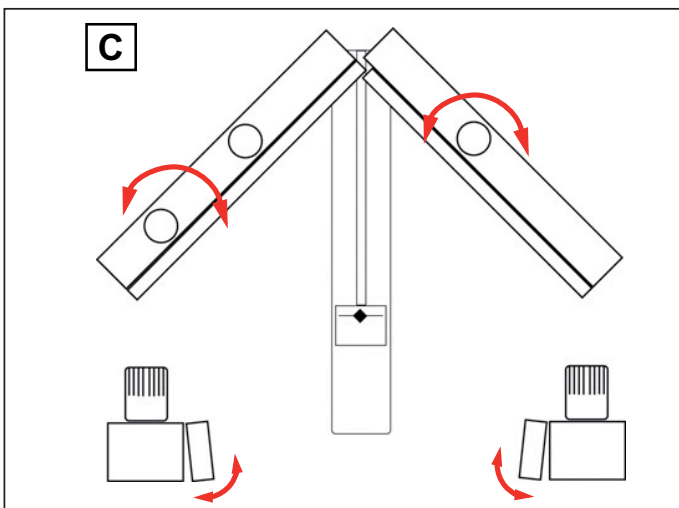



### Double hydraulic topper adjustment (optional accessory)

To carry out adjustments, proceed as follows:

1. Position the mouldings on the working bench.
2. Loosen the screw on the bottom of each cylinder using an appropriate tool (A) and lift/lower the cylinder body to the required height.
3. If the corner is narrow and you wish to use one cylinder only, close the handle on the cylinder you wish to block (B). In this way the stem remains stationary.
4. If the frame is wide, loosen the knob on the cylinder support (C) and move it so that the stopper is perpendicular to the stapling point.

#### **CAUTION!**

**Avoid lifting the stoppers with your hands: after slackening the two handles, activate the down command of the vertical blocking device, placing a spacer under the stopper you wish to lift or inhibit.**

**Tighten the handles to keep the stoppers still and exclude self-lifting.**

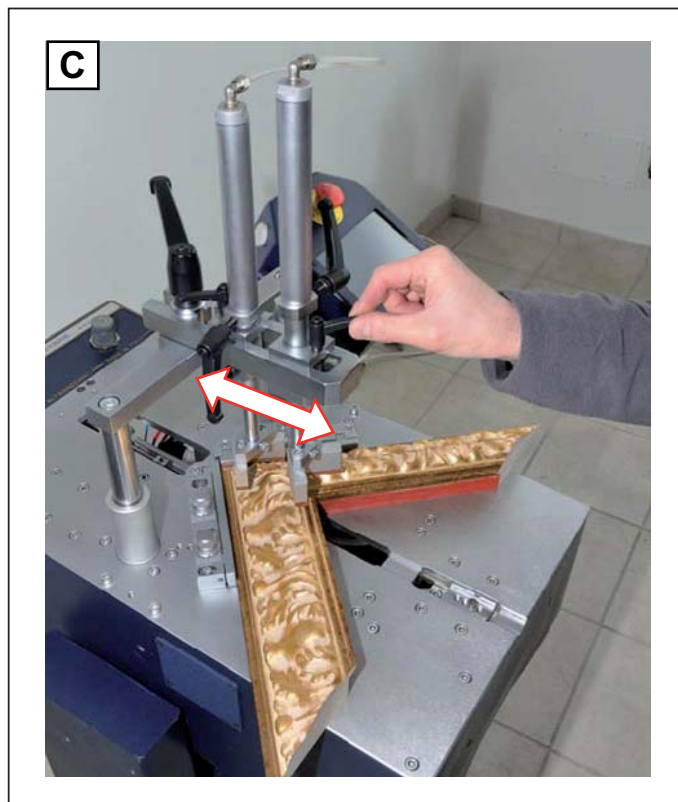
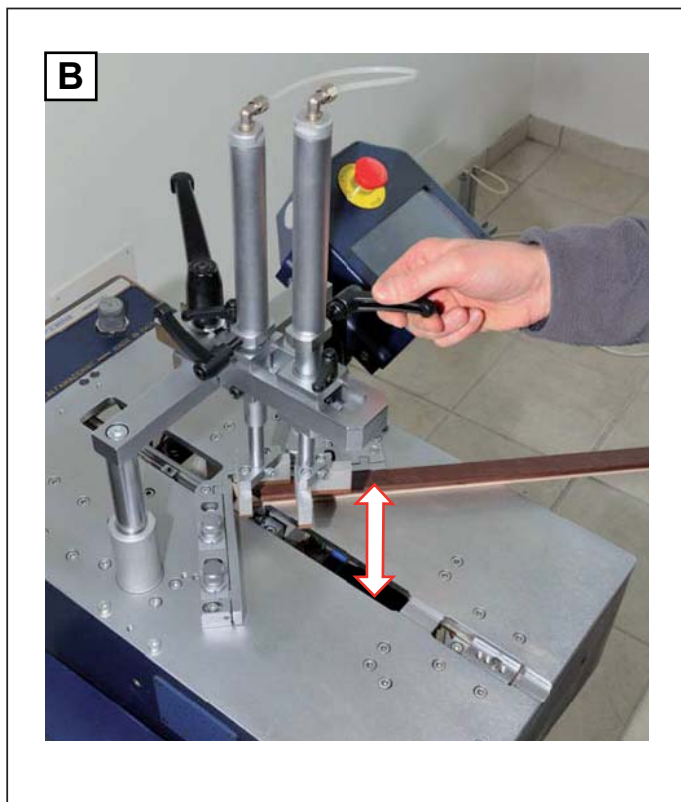
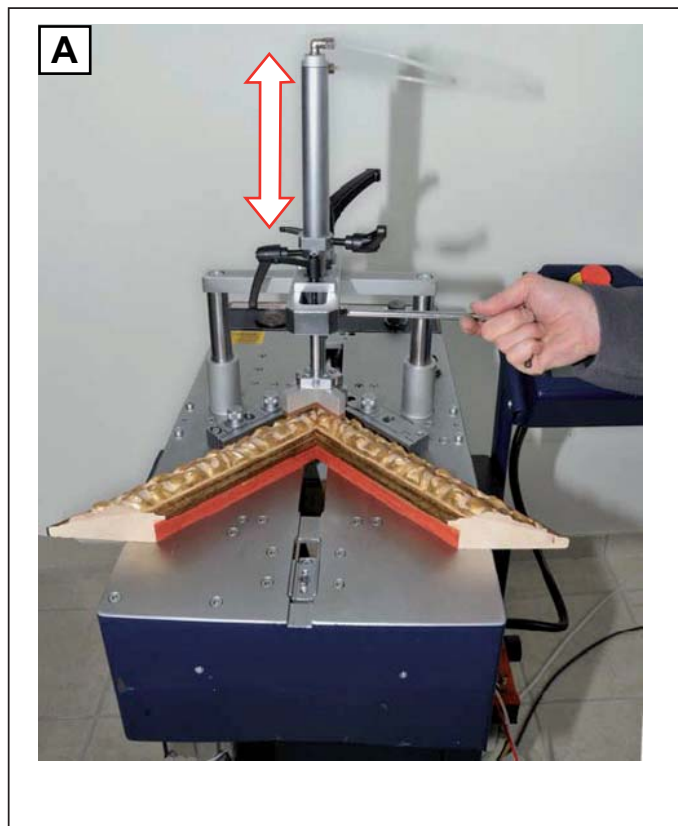

### Replacing the vertical clamp unit

To use one or the other of the vertical clamp units, proceed as follows.

#### Single stopper insertion

To insert and adjust, proceed as follows:

1. Loosen the locking handle on the vertical clamp unit (A) and lift it out.
2. Insert and position the single vertical clamp unit, securing it in place by tightening the locking handle (B).

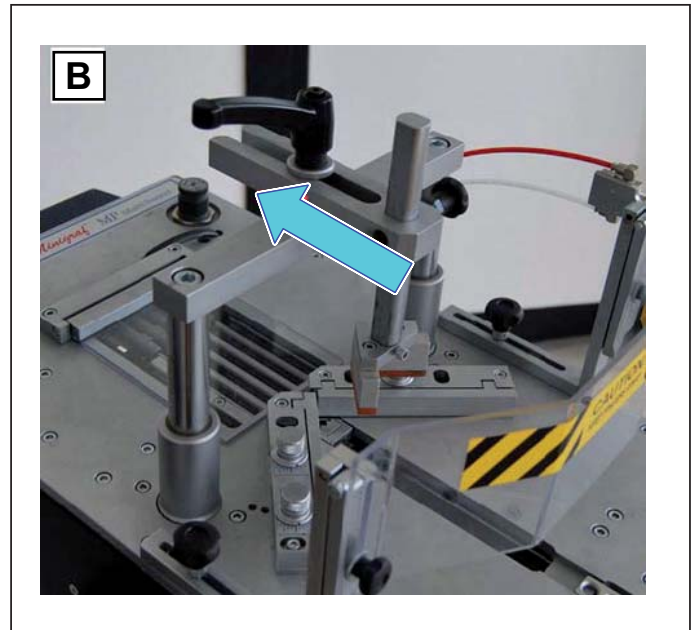
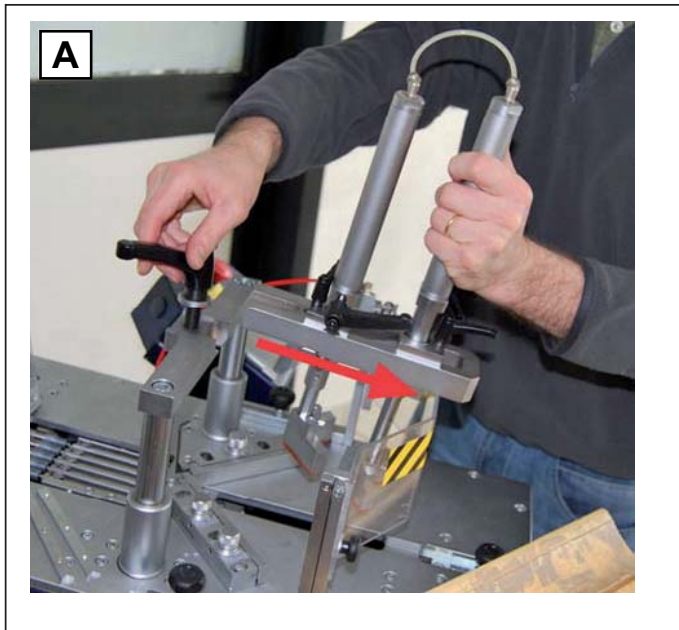

#### Single stopper adjustment

1. Act on the locking handle to loosen the single stopper's fork support.
2. Slide the fork support horizontally in order to position it above the corner to be joined and lock.
3. Slide the stopper rod and by acting on the relative click knob, adjust the vertical position of the stopper (C).

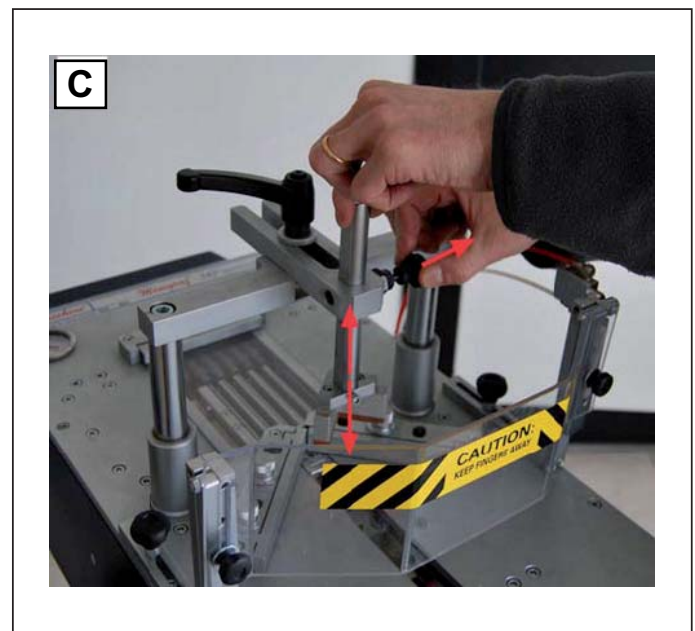

#### NOTES

It is advisable to adjust the height of the stopper at a distance of at least 1 cm (1/2 in) over the corner to be joined to allow for the corner to be moved.

#### Interchangeable stoppers

D	Interchangeable rubber stoppers: Soft (blue) Medium (yellow) Hard (black)
E	Double stopper holder
F	Single stopper holder

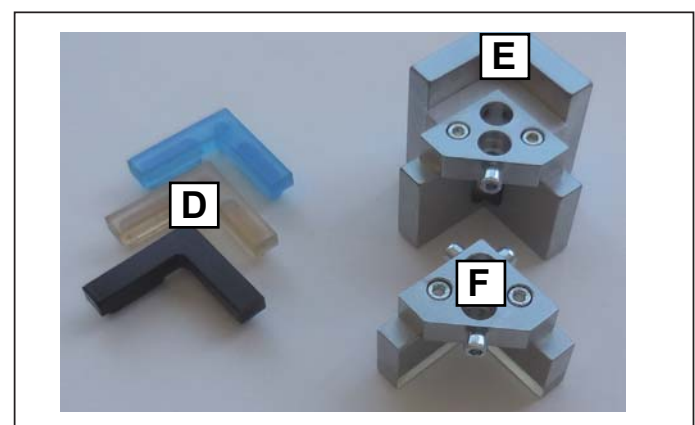



### **Installation of interchangeable stoppers**

The interchangeable stoppers (A), based on work requirements, may be applied to:

- Single stopper holder
- Double stopper holder
- Magnetic stopper holder

Install the stopper (A) for the required hardness in the stopper holder, positioning it under the slot and manually pressing it in place.

To remove the stopper (A) simply pull it out with your hand by gently taking hold of one of the two sides.

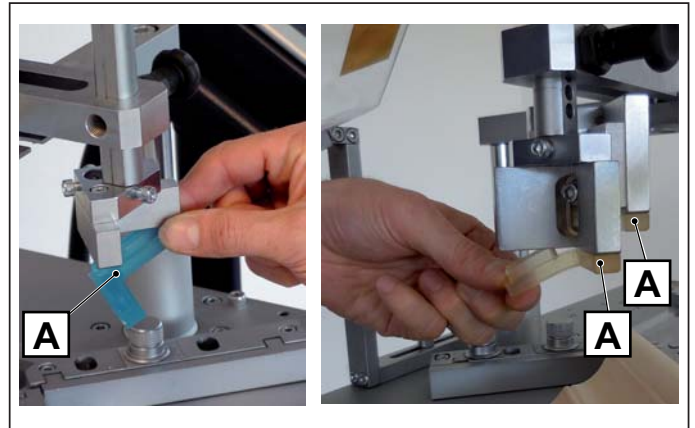

### **Adjusting the tilt of the workbench**

Depending on the operator's needs, the workbench can be tilted.

To carry out adjustments, proceed as follows:

1. Loosen the handle underneath the working bench (B).
2. Slowly tilt the working bench to the required position (C).
3. Re-tighten the handle once the required position has been achieved.

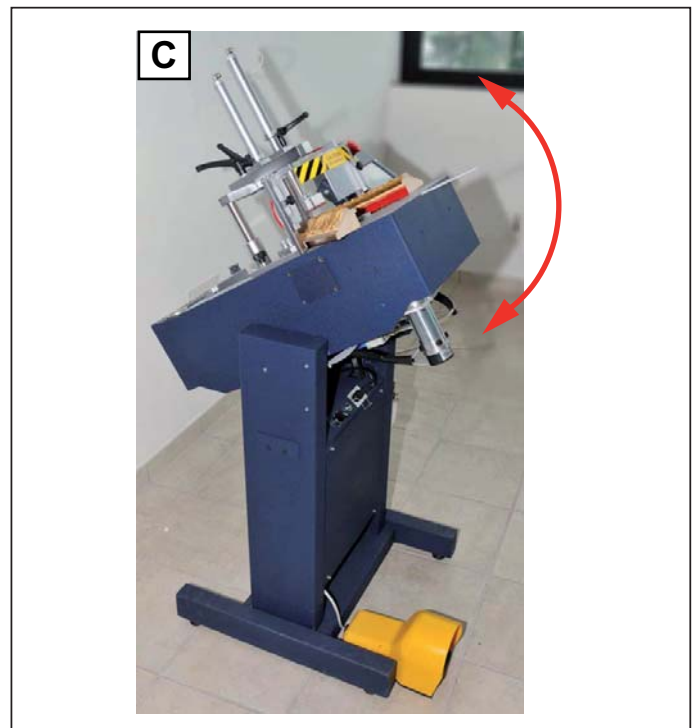
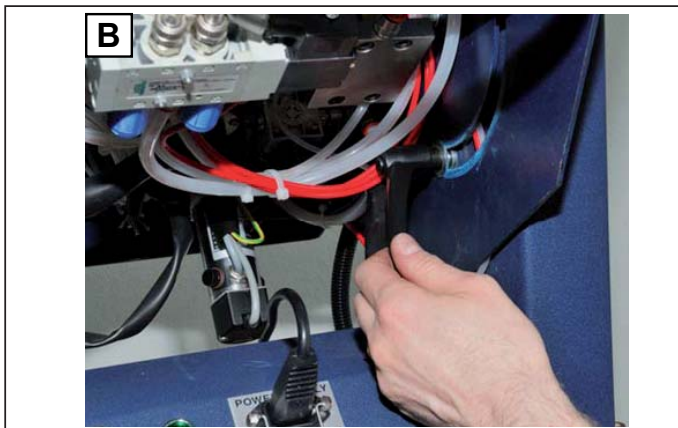

**Operating pressure regulation**

The machine runs at 2 operating pressures:

1. Nailing pressure:  
This is the pressure used by the V-nail firing unit to insert the V-nails in the frame and corresponds to the line pressure. This pressure is regulated by acting on the main pressure regulator with filter (installed on the side of the support stand) to a value of between 5 - 7 bars, depending on the hardness of the wood being handled.
2. Pressure of the devices designed to block the mouldings:  
This is the pressure used by the vertical and horizontal stoppers during V-nail insertion. This pressure is shown on the pressure gauge located on the top surface of the machine (A).
3. Select the most suitable pressure values for the materials being handled: low pressure for soft materials, high pressure for hard materials (see table B).



B.

Durezza / Hardness	Pressione consigliata / Air Pressure
Bloccaggio Soffice Soft Clamp	2 bar / 30 psi
Soft Wood Soft Wood	3 bar / 43 psi
	4 bar / 58 psi
Legni Medi / Medio-Duri Medium/Hard Wood	5 bar / 72 psi
	6 bar / 87 psi
Legni Molto Duri Very Hard Wood	7 bar / 100 psi
	8 bar / 115 psi

**NOTES**  
Increase the pressure by about 10 - 20% for H15 or overlapping V-Nails.

**How to adjust the clamping pressure**

**1. BY MEANS OF MANUAL REGULATOR:**

To alter the operating pressure, proceed as follows (C):

- Lift the knob by about 3-4mm.
- Turn it clockwise to increase the pressure, or anticlockwise to reduce the pressure.
- Press the knob to lock it back in place.

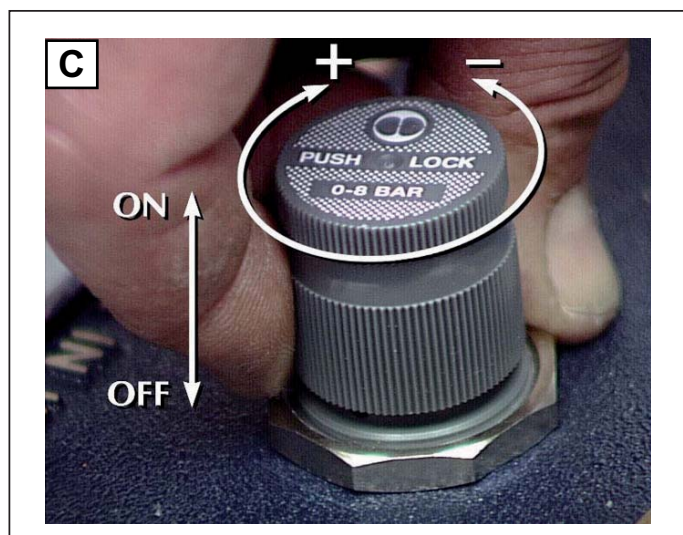

## 2. AUTOMATIC ADJUSTMENT, CAPS:

The electronic pressure regulator (CAPS) is a device which automatically adjusts the clamping pressure removing the need for manual interventions by the operator.

The pressure is set and memorized in each program by means of the special interface on the screen.

### CAPS Activated

The pressure is selected on the display and stored in the work program.

The icon with two columns shows the set speed and pressure levels.

### CAPS not activated

The clamping pressure is adjusted manually using the pressure regulator on the pneumatic panel.

The icon with 1 column shows the speed level.

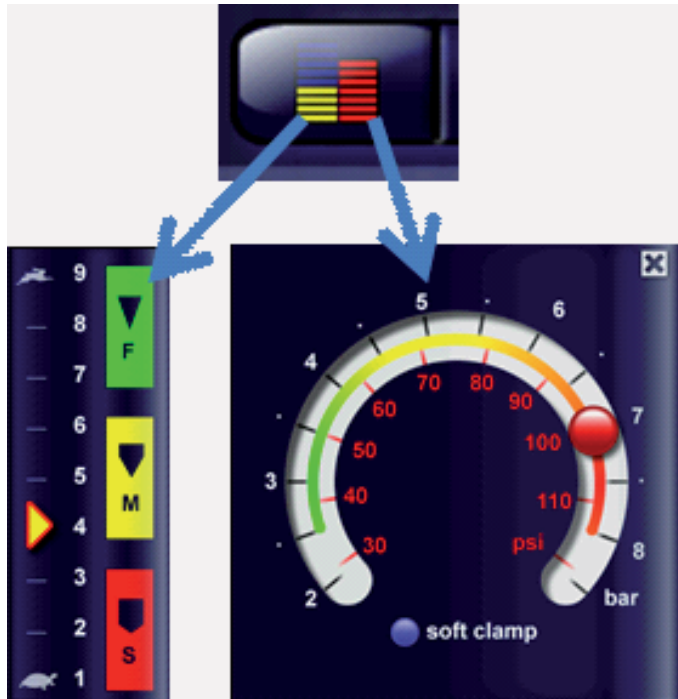

### “Soft Clamp” function

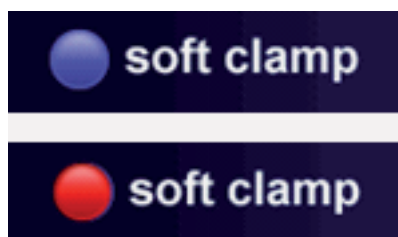

Soft clamp not enabled: the pressure is not reduced during clamping.

Soft clamp enabled: the pressure is reduced during clamping.



#### NOTES

For further information, please refer to “ANNEX A”.

**Adjusting V-Nail positioning**

The machine is equipped with a mobile V-Nail expulsion unit, assembled on an electrically-controlled carriage which determines the exact V-Nail insertion point with extreme precision. The maximum stroke of the carriage is 145 mm. Various insertion points (A) can be defined within this range.

The various points are determined in the program which the operator must enter for each work cycle. To create programs and define insertion points see the PRODUCTION PARAMETERS SETUP chapter.

- This picture shows 4 V-nails inserted along the corner join (A).
- Depending on the thickness and profile of the moulding (B), several V-Nails can be inserted in the same point.

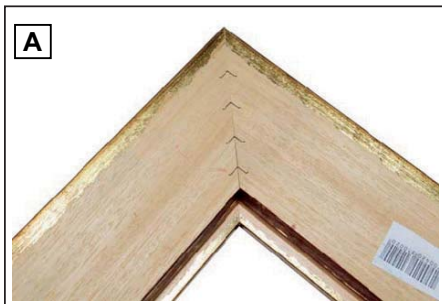

**SUGGESTIONS FOR MAKING PERFECT JOINS**

1) V-nail types

In order to ensure that the machine can make top quality joins using a wide variety of materials, different V-nails are available with different degrees of sharpness suitable for use with different hardness values and characteristics of the materials being handled. V-Nails can be divided up into the following categories:

Material	Recommended sharpness
Soft woods and plastic	SW transparent stick
Medium wood	MW brown stick
Hard wood	HW green stick
Very Hard Wood and MDF	HS red stick

 It is advisable to carry out a check on the material in question for selecting the most suitable sharpness.

2) Stapling positions

The following guidelines are designed to help you get the best results in terms of quality joins:

- Avoid inserting V-nails close to the moulding edge. The minimum recommended distance from the outer edge is at least 10mm.
- When creating a join with just one V-Nail, position the V-Nail on the centre line of the frame.
- If you wish to insert 2 or more V-Nails for each join, it is advisable to insert the outer V-Nail at 1/3 from the outer edge and the inner V-Nail 1/4 from the inner edge.
- Position the vertical stopper as shown in the figure.

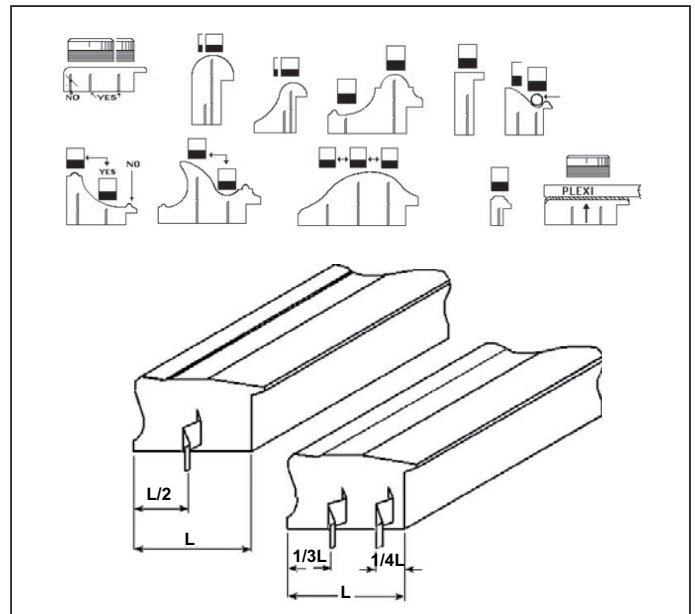



#### 4.4.4. RESERVED PAGES

The following paragraphs summarise the steps required to access the reserved pages where advanced machine settings can be entered or modified.



Press the “KEY” icon to access the advanced functions. For security reasons, access to advanced functions is password-protected. Enter the valid access code using the numeric keypad.



The main advanced features available upon entering the access code are described below:

- **Machine maintenance and setup.**
- **Utility and program management.**
- **GUI diagnostics .**

CONTACT YOUR LOCAL DISTRIBUTOR OR SERVICE CENTRE TO REQUEST THE ACCESS CODES.

#### MACHINE MAINTENANCE AND SETTING

The machine is supplied already fully adjusted ,but in the event of the replacement of a component or after mechanical maintenance, it may be necessary to create new adjustments or perform new checks.

The menu offers a choice of low-level areas required for the machine adjustment.

Select to perform the following adjustments:

- A. Head adjustment
- B. U600 V-nail magazine adjustment (control not available on the U500 version).
- C. Barcode
- D. Pressure regulation
- E. Diagnostics;
- F. Customizable parameters.
- G. Counters.

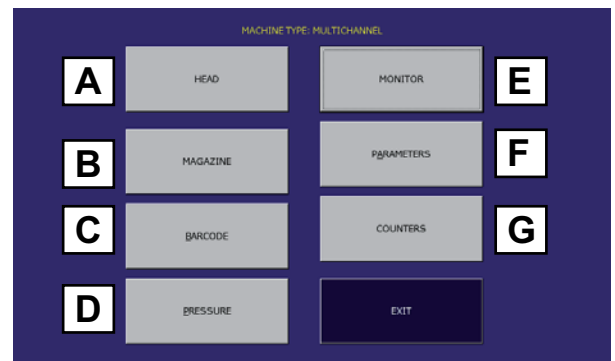

#### U600I head adjustment

- H. Frees motor control so the V-Nail firing unit can be moved by hand.
- I. Controls the motor to run machine zeroing by searching for a mechanical stop as a reference for positions.
- L. Memorises the current head position as a point of origin in relation to the position of the alignment fences.
- M. Direction and movement controls to move the head; the movement is performed by keeping the button pressed.
- N. Displays the position of the head (mm/inch) in relation to the alignment fences; used to move the head to a new position.

Adjustment of head origin in relation to the alignment guide positions (ORIGINS):

- The V-nail firing position in the program refers to the distance between the head and the alignment fences intersection point, called Zero Origin. Zero Origin must be acquired.
- Touch the “ZERO” button to zero the machine’s V-nail firing unit.
- Move the head using the JOG+ and JOG- buttons or set the motor to “FREE RUN” to accurately position the head under the alignment fences.
- Refer to the head “V” from which the V-nails are fired so that it is positioned at the intersection of the alignment fences, i.e. at the outer edge of the frame.
- Touch the “ORIGIN” button to memorise the new “ZERO” position to which the V-nail firing positions of all programs will refer.

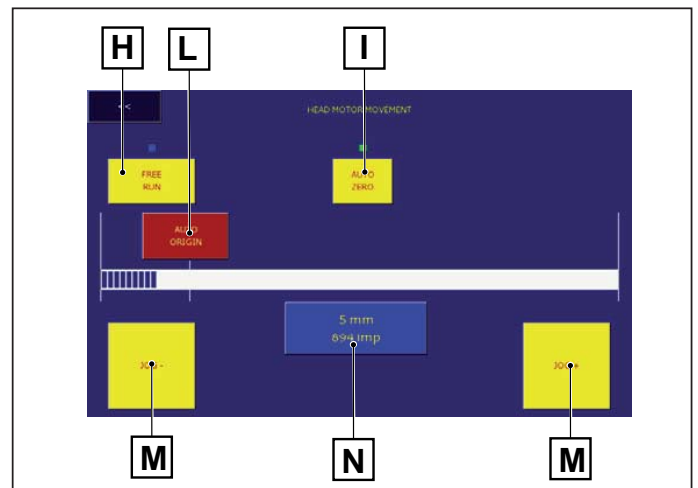

**U600 magazine adjustment**

- A. Controls the solenoid valve that activates the magazine release cylinder.
- B. Controls the V-nail pusher cylinder opening/closure solenoid valve.
- C. Controls the motor to run machine zeroing by searching for a mechanical stop as a reference for positions.
- D. Memorises the mechanical position of the first magazine channel, V-nail H5.
- E. Positions;
- F. Memorises the mechanical position of the last magazine channel, V-nail H15.

- Mechanical adjustment of the V-nail magazine channel positions.
- The position of each magazine channel must perfectly match the conical seats of the L-block support from which V-nails are fired by the hammer, to avoid mechanical jams.
  - Only the two outer positions of the magazine need to be acquired; the program will automatically calculate the others.
  - Press "ZERO" in order to zero the magazine in relation to the mechanical stop.
  - Press the "INDEX" button to release the magazine so that it can be moved manually to the two positions to be acquired.
  - Position the magazine in such a way that the H5 V-Nail channel is in front of the L-block support, position #1.
  - Block the magazine, using the "INDEX" button, until the channel enters into the L-block support seat. Force it by hand to make sure it engages perfectly.
  - Touch the "AUTO MIN" button to memorize position #1 (H5).
  - Release the magazine again to move it until the H15 V-Nails channel is in front of the L-type support, Position # 5;
  - Block it so the channel enters the L-block support. Make sure it is correctly engaged and then memorise the position using the "AUTO MAX" button.
  - Press "Position #" keys to check the correct positioning of all the other magazine channels.

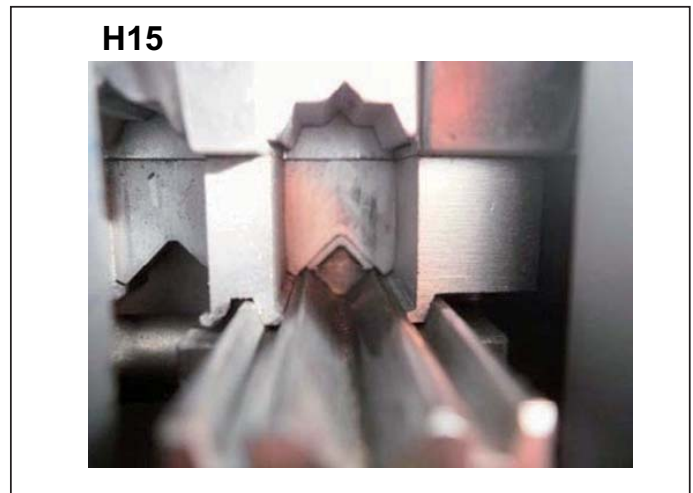
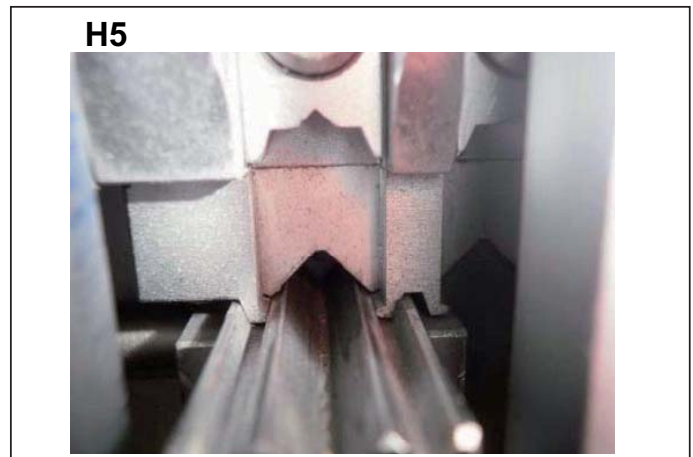
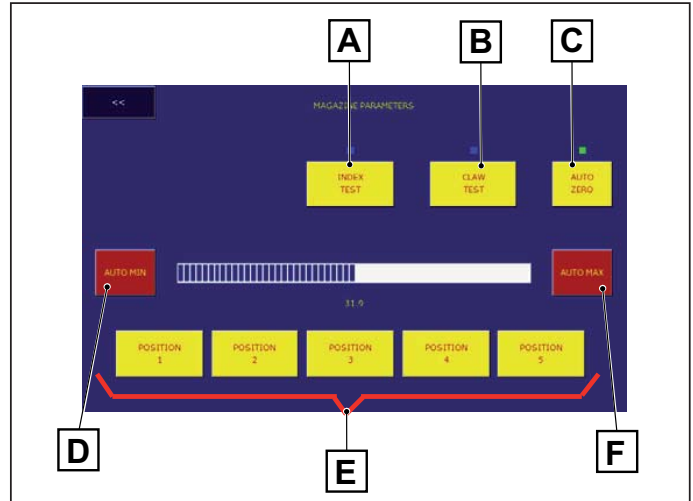

**Diagnosics**

- G. Commands for output forcing (solenoid valves); touch the button to turn the output on/off.
- H. Displays the switch status of the outputs connected to the electronic card (solenoid valves): "red" when the output is active;
- I. Displays the logic status of the input devices connected to the electronic card: red when the input is active.
- L. Displays power supply presence for controlling the "M" and "H" motors and the voltage level.

**Machine customization**

*NOTE - Information on "Machine Customization" can be found in document "APPENDIX A" supplied with this manual.*



**UTILITY**

Most utilities can be accessed using a password.  
Contact your Distributor or Service Centre to request the access codes.

**Program Backup (saving)**

- Insert a USB flash drive into one of the available USB ports located on the side of the operator panel.
- Enter the password (copyToUsbPassword) to start copying all the programs from the CPU memory onto the USB flash drive.



**Importing programs**

Enter the password (copyFromUsbPassword) to import the contents of the USB flash drive into the CPU memory.



**Program Transfer**

- Programs can be transferred from one machine to another by exporting and importing them via a USB flash drive.
- Make sure the USB flash drive is the right way up before inserting it into the port. Do not force it into the port as you may damage both port and flash drive.



**Daily production reports**

**Displays daily production figures**

It is possible to consult a daily production report which covers a minimum of 1 to a maximum of 45 days. Ten-day memorizing is set as a default value. By reducing the number of days to be memorized, i.e. the content of the database which includes the total number of days already memorized, part of the data will be deleted thus increasing space available for storing programs.

- 1) Act on the "KEY" button to enter the password on both the "Home" page and "Service" menu.
- 2) Enter the password 990099 of the "productionDataPassword" to access the "Production Record" page.
- 3) The production record page holds the daily production data depending on the "last ## days" setting. Act on the "UP" and "DOWN" buttons to consult the whole register.
- 4) Enter the "(last ## days)" field to modify the number of days' reports you wish to keep stored in the memory (minimum 1 day - maximum 45 days).
- 5) Press the "USB" icon to download the whole report onto a USB flash drive as a "production\_data.csv" file which can be imported into Excel.
- 6) An example of a .csv file imported into Excel is provided below with the meaning of the individual column headings. The column headings are not automatically loaded.

 Always download the production registers onto a USB flash drive before updating the software as this operation will delete the entire contents of the database.

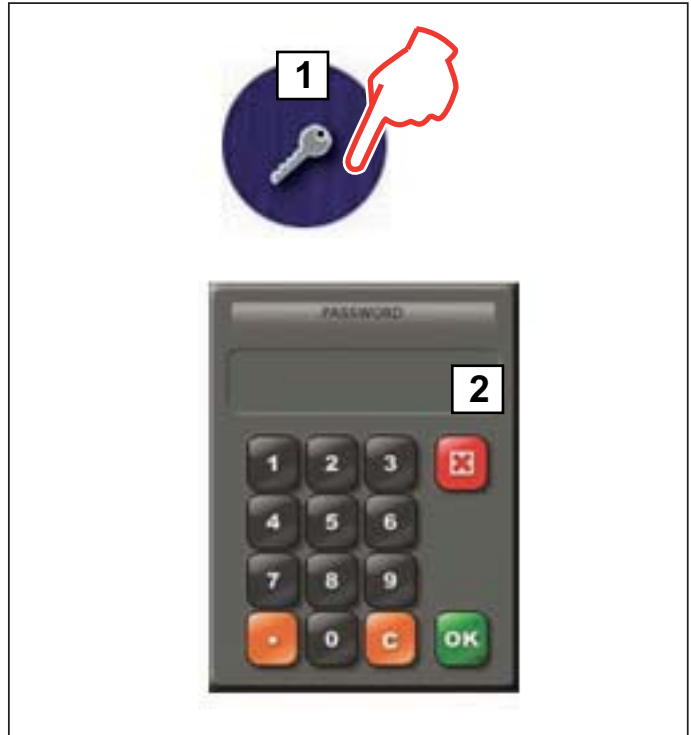

Production Data Password 990099

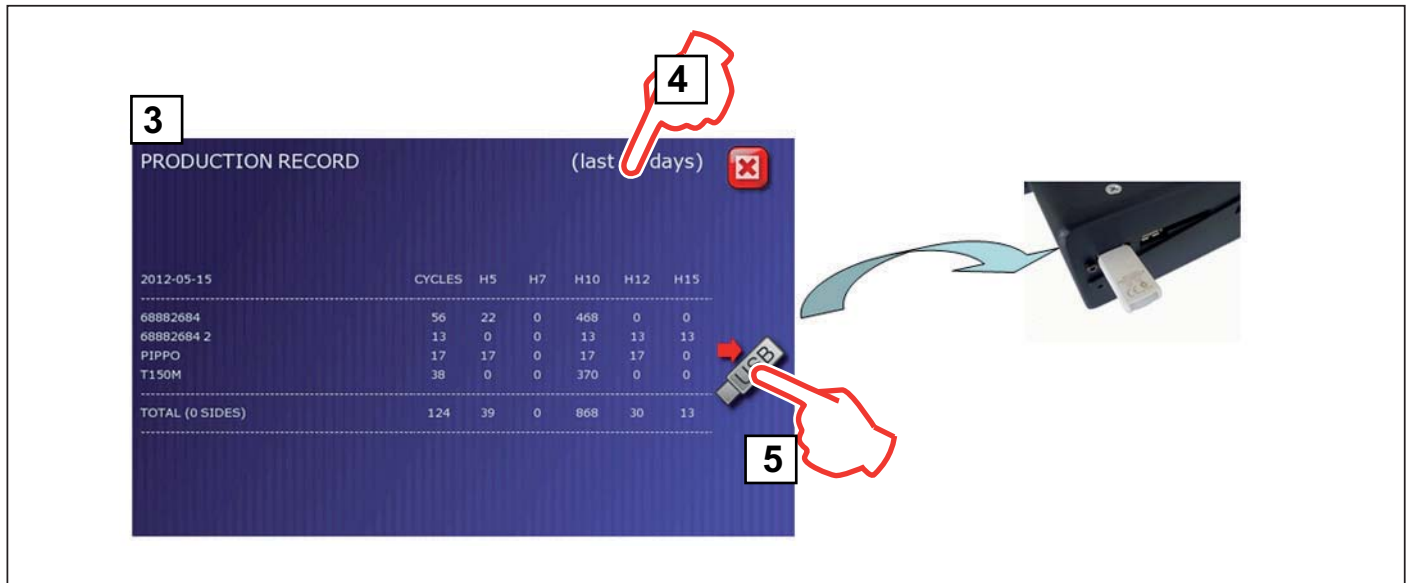

**6**

Reference data	Program	Date	Sides	Cycles	H5	H7	H10	H12	H15
4517	PLUTO	14/05/2012	4	14	28	0	28	14	28
4517	PLUTO	14/05/2012	6	8	16	0	16	8	16
4517	PLUTO	14/05/2012	8	22	44	0	44	22	44
4517	T150M	14/05/2012	4	23	0	0	115	0	0
4518	68882684	15/05/2012	4	56	22	0	468	0	0
4518	PIPPPO	15/05/2012	4	17	17	0	17	17	0
4518	T150M	15/05/2012	4	38	38	0	370	0	0
4519	68882684	16/05/2012	4	11	11	0	11	11	11
4519	T150M	16/05/2012	4	5	5	0	25	0	0



## GUI DIAGNOSTIC

Upon machine start-up, during the system booting sequence, a diagnostic procedure is performed to check the machine model for which the Graphic User Interface (GUI) has been programmed (i.e. U500 or U600).

The GUI application is exactly the same for U500 and U600 machines, but it has been configured for either one or the other for obvious operating differences.

Therefore, GUI settings are operational only if the GUI application is connected to the machine model it was intended for.

In the event of replacing the control console with a new one or one with a different setup, the technical assistance centre may be authorized to reset the “machine model” as long as the access code for said operation is known to them (“changeModelPassword”).

The GUI application will start only when the required hardware matches the original setting.

The procedure to follow to resolve an incompatible setting (GUI installed on a U600 machine but set up for a U500 model) is described below:



1 Hardware check or communication error.

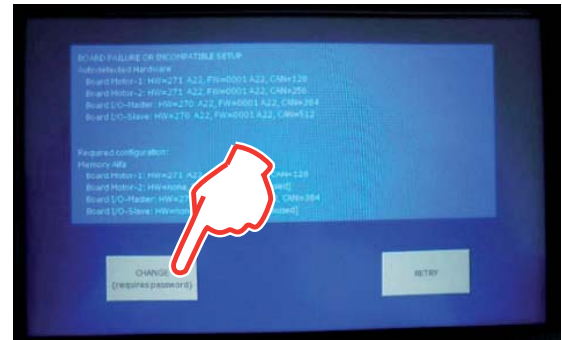

2 Diagnostic page for hardware incompatibility.



3 Enter password to “change machine model”.

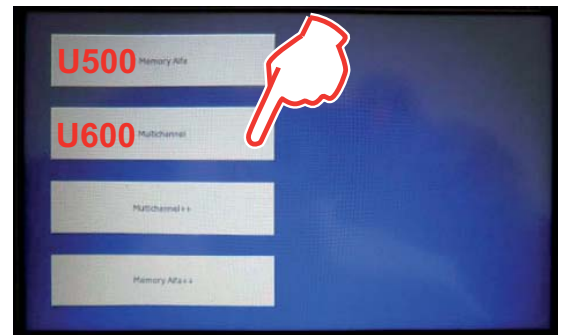

4 Machine model selection page.

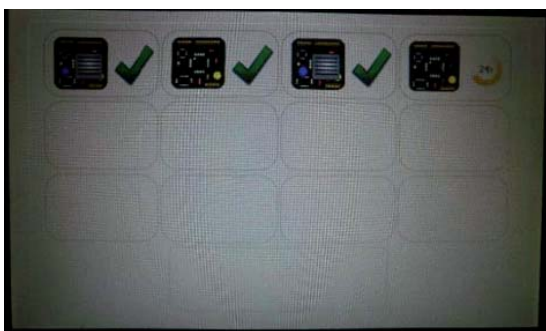

5 Selected machine model correct diagnostics.

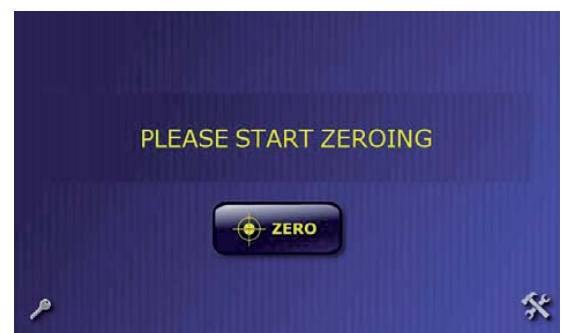

6 Machine OK >> Home page.

#### 4.5. WORKING CYCLE

 **DANGER – CAUTION**  
*During normal use, the machine must only process the products/materials indicated in this manual.*

Safety measures and the indications on residual risks must always be observed during machine operation.

For details on the functions of each control and signalling device, refer to the “Layout and description of the control and signalling devices” given in the electrical diagram provided as an attachment to this manual.

Check the V-Nail magazine is full and the head is installed correctly; reset any emergency conditions and close the mobile guards.



Insert the plug in the socket and switch the illuminated green power switch to ON/1.



Wait for the operating system to boot; when the home page appears, press the zero button to set the machine.

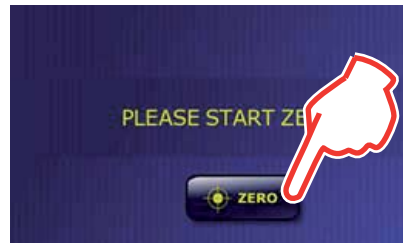

The machine is ready to commence operations. Start by placing the mouldings on the working bench.



Press the vertical lock pedal and then press the start button on the touch-screen.



#### 4.5.1. CYCLE STOP

If, during the automatic operating cycle, you need to stop the machine in an emergency, press the “EMERGENCY STOP BUTTON”.

Activating this device causes the machine to stop immediately, whatever the operation in progress.

When the Emergency Stop Button has been pressed, an alarm message indicates the machine’s state of inactivity and all controls on the touch screen are disabled until the system has been reset.

An emergency stop or intervention of any safety device stops the machine in the precise condition it finds itself in and consequently interrupts the production cycle underway.

#### 4.5.2. SWITCH-OFF



#### DANGER - WARNING

**ALWAYS WAIT UNTIL THE MACHINE WORKING CYCLE HAS ENDED BEFORE SWITCHING OFF THE MACHINE. BEFORE SWITCHING OFF THE EQUIPMENT, MAKE SURE NO WORKPIECES ARE LEFT ON IT.**

At the beginning of each cycle, all machine moving parts must be placed in their original starting position.

To do this, use the operating control devices on the operator panel (see this Operating Manual).

The cut-off devices for external power sources must be turned to “OFF” or “CLOSED”.

1

Place the switch on OFF / 0 and remove the power cable plug from the socket.



2

Remove the compressed air line from the machine.



## 5. MAINTENANCE, TROUBLESHOOTING, AND CLEANING

### 5.1. MAINTENANCE TECHNICIAN REQUIREMENTS

The term "maintenance" does not just cover periodical controls of normal machine operation, but also the analysis and consequent rectification of any of those problems which for any reason stop the machine from working properly or not at all.

Specifically, personnel appointed to perform the servicing, cleaning, replacing of parts and troubleshooting, must work in compliance with the following aims:

1. limit the deterioration of wear parts.
2. reduce accidents to the absolute minimum.
3. reduce costs arising from faults.
4. limit the number and duration of interventions.
5. work in collaboration with the line operators to improve the efficiency of the plant.

### 5.2. WORK STATIONS AND MAINTENANCE TECHNICIAN DUTIES

The maintenance technician duties are:

- to perform tooling operations and adjust mobile parts on the machine,
- to calibrate, adjust and clean internal machine parts,
- to clean the inside of the machine (disassembling parts if necessary), carry out maintenance, lubrication, assistance operations, troubleshooting and the replacements of worn or damaged parts or structural elements.

The work zones that may present risks for the machine's maintenance technician are the following:

- the area relative to tooling, calibration, adjustment, lubrication, troubleshooting, worn and broken part replacement operations, as indicated in this instruction manual,
- the areas in and around the machine during the movement of mobile parts,
- the areas around electrical enclosures, electrical cables and compressed air lines,
- the areas around the fixed guards.

Schematic indications of the danger zones for machine maintenance technicians:

- A. the V-nail magazine
- B. the double stopper
- C. the V-Nail firing head.
- D. horizontal locking

Useful references that aid in the traceability and identification of electrical components are provided in the relative diagrams, tables, etc.. all the aforementioned documents are supplied together with the machine.

In addition, all the operating and maintenance documents of the safety components (which must be referred to for maintenance tasks), are supplied with the machine.

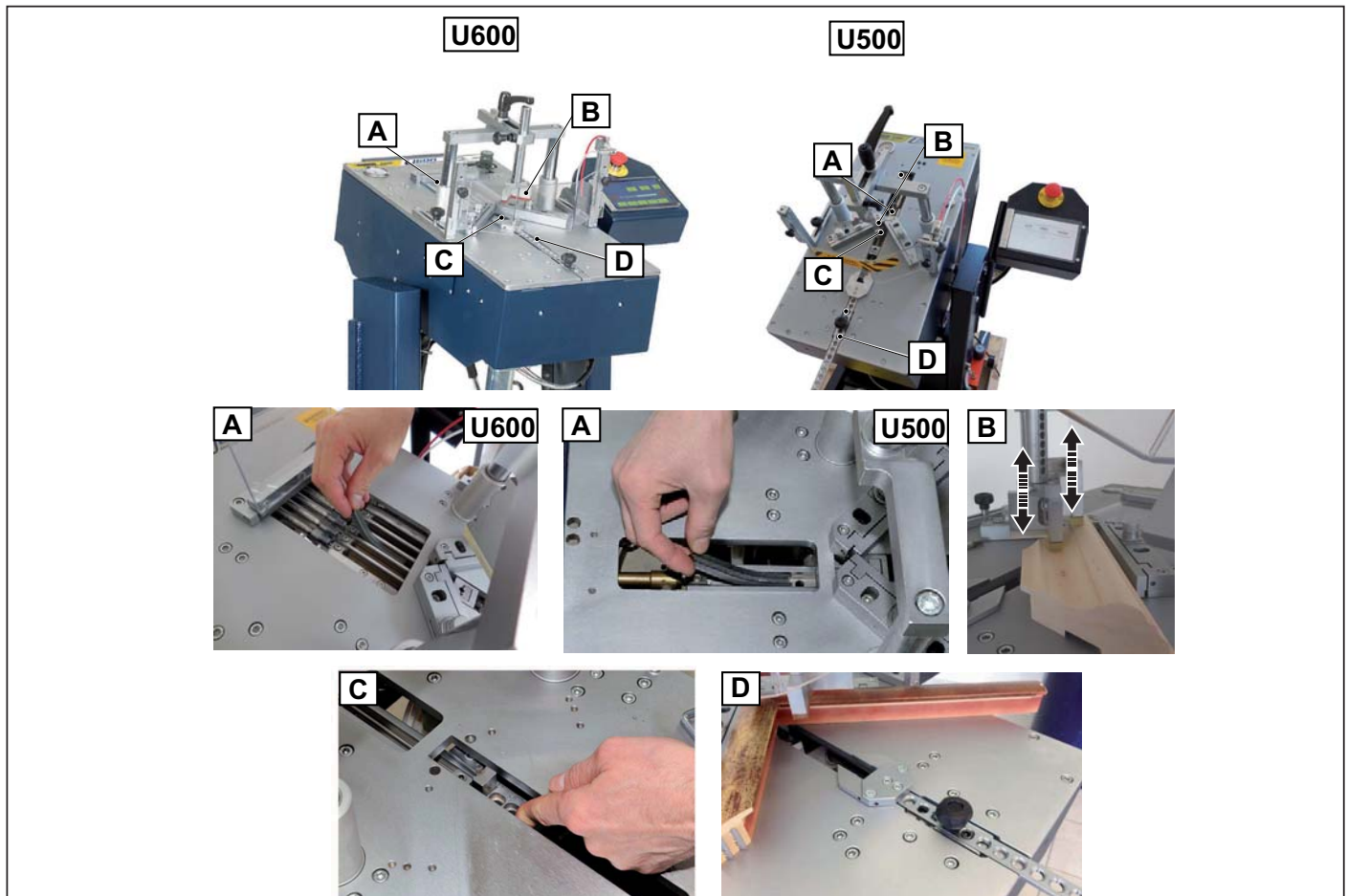



### 5.3. MAINTENANCE PRESCRIPTIONS

**DANGER - WARNING**

**ALL THE MAINTENANCE, CLEANING AND PARTS REPLACEMENT MUST BE CARRIED OUT SOLELY AND EXCLUSIVELY WITH THE MACHINE DISCONNECTED FROM ALL POWER SUPPLIES.**

It is prohibited to perform any maintenance work on parts that are in motion.

### 5.4. GENERAL WARNINGS

**DANGER - WARNING**

**BEFORE PERFORMING ANY MAINTENANCE, CLEANING, REPLACEMENT OF PARTS AND TROUBLESHOOTING PAY THE UTMOST ATTENTION TO THE DECALS AFFIXED TO THE MACHINE AND TO THE ELECTRICAL EQUIPMENT. DURING ALL ACTIVITIES DO NOT TAMPER WITH OR DEACTIVATE ANY OF THE SAFETY DEVICES FOR ANY REASON, EITHER TO CREATE BYPASSES OR TO USE THEM FOR PURPOSES OTHER THAN THEIR INTENDED USE AS PRESCRIBED BY THE MANUFACTURER.**

After performing any of the above tasks on the machine, reset and reactivate all the safety devices.

Do not tamper with or deliberately damage the protective screens nor remove or conceal the warning notices. In the event of deterioration or illegibility of the safety decals immediately order replacements from the electrical equipment supplier.

**DANGER - WARNING**

**BEFORE PROCEEDING WITH MAINTENANCE, CLEANING AND/OR THE REPLACEMENT OF PARTS, ALWAYS PUT UP A SIGN WHICH IS CLEARLY VISIBLE INDICATING THAT MAINTENANCE OPERATIONS ARE UNDERWAY AND THAT THE MACHINE CAN ONLY BE RESTARTED AFTER HAVING DULY ASCERTAINED THAT ALL OPERATIONS HAVE BEEN COMPLETED AND ALL SAFETY GUARDS HAVE BEEN REPLACED.**

**BEFORE PERFORMING ANY MAINTENANCE, CLEANING, REPLACEMENT OF PARTS AND TROUBLESHOOTING PAY THE UTMOST ATTENTION TO THE DECALS AFFIXED TO THE MACHINE AND TO THE ELECTRICAL EQUIPMENT.**

After performing any of the above tasks on the machine, reset and reactivate all the safety devices.

Do not tamper with or deliberately damage the protective screens nor remove or conceal the warning notices. In the event of deterioration or illegibility of the safety decals immediately order replacements from the electrical equipment supplier.

## 5.5. ISOLATION FROM EXTERNAL ENERGY SOURCES

During maintenance, cleaning and replacement of parts, the machine must not be used and no commands must be transmitted. Before performing any maintenance, lubrication, cleaning and replacement of parts etc. external energy supplies must be disconnected. All disconnecting devices must be padlocked in the "0" (OFF) position.



Place the switch on OFF / 0 and pull the power cable plug out of the socket.



Turn the knob to discharge residue pressure from the pneumatic system and disconnect the compressed air line.

## 5.6. ROUTINE MAINTENANCE

Personnel responsible for carrying out the operations described in this chapter must have read, understood and consequently observe all the safety prescriptions, in particular:

1. waiting for the stopping times, before inserting limbs or parts of the body into the machine danger areas,
2. the adequate use of personal protective devices and safety accessories needed to perform cleaning operations inside the machine's danger areas,
3. It is prohibited to perform any repair or adjustment work on moving parts,
4. before performing any maintenance, cleaning and replacement of parts, the machine must be isolated from all energy supplies.

Furthermore, all general rules must be observed to keep the machine in perfect working order:

1. keep the machine clean and tidy,
2. avoid all damage,
3. avoid a situation wherein make-shift or urgent repairs become commonplace,
4. do not perform work on the machine which produces swarf; for example, should it be necessary to drill holes, carefully check that no residues end up in machine parts,
5. for disposal of worn or replaced materials, observe the relative legislation in force.

## 5.7. TASKS THAT CAN BE PERFORMED BY THE OPERATOR

A list of all the periodical checks/inspections, adjustment and control operations and ROUTINE MAINTENANCE operations which can be carried out by the machine operator is provided below.

The position of the machine components is shown in the layouts provided as an appendix to this manual.

FREQUENCY	CHECK	METHODS AND RESULTS
<b>Before each shift</b>	<p>Working area:</p> <ul style="list-style-type: none"> <li>• must be clean and free from dust</li> </ul>	<p>The work station and all the parts outside the machine must be cleaned and all dust and objects must be removed which could impede correct operation and/or compromise the machine's original safety conditions.</p> <p>Remove all shavings from the machine with a jet of compressed air and lint-free cloths.</p> <p>For any type of intervention or to replace parts, call in the maintenance service.</p>
<b>Before each shift</b>	<p>Check operation:</p> <ul style="list-style-type: none"> <li>• of the emergency stop device;</li> <li>• of the command/control devices relative to safety;</li> </ul>	<p>All devices and circuits indicated must perform the function they were designed for. Directly command the devices to ensure they bring about the expected function (e.g. stopping, etc.).</p> <p>At the first sign of problems it is necessary to remedy the situation by implementing an inspection procedure to check the correct electrical and mechanical operation of the devices.</p> <p>The actuators and all parts must in any case be replaced at the first sign of wear or breakage.</p> <p>For any type of intervention or to replace parts, call in the maintenance service. Parts must always be replaced using original spare parts or at least parts which provide equivalent quality and safety .</p>
<b>Before each shift</b>	<p>Visual inspection of the condition:</p> <ul style="list-style-type: none"> <li>• of fixed guards</li> </ul>	<p>All fixed guards must perform the function they were designed for. Check their integrity, both internally and externally and make sure there are no signs of wear or breakage.</p> <p>For any type of intervention or to replace parts, call in the maintenance service.</p>
<b>When necessary</b>	<p>Visual inspection:</p> <ul style="list-style-type: none"> <li>• blocked V-nails</li> </ul>	<p>During operation it is possible that V-nails come out of the magazine and remain in circulation near the nailing head. Remove them using the magnetic pen provided.</p> 
<b>At least once a week</b>	<p>Visual inspection of the condition:</p> <ul style="list-style-type: none"> <li>• of all dataplates</li> </ul>	<p>If they become unreadable new ones must be requested from the manufacturer or they must be replaced by the user with others carrying the exact same information.</p>

Parts must always be replaced using original spare parts or at least parts which provide equivalent quality and safety .

The instructions concerning the replacement are not given in this manual and they must therefore be explicitly requested from the machine manufacturer, which reserves the responsibility for the replacement interventions.

**5.8. TASKS THAT CAN BE PERFORMED ONLY BY MAINTENANCE TECHNICIANS**

The ROUTINE MAINTENANCE operations which must be performed by a maintenance technician are indicated below.

The instructions concerning the replacement are not given in this manual and they must therefore be explicitly requested from the machine manufacturer, which reserves the responsibility for the replacement interventions.

FREQUENCY	CHECK	METHODS AND RESULTS
Every 1,000,000 V-nails inserted	Check / replace: • gaskets and hammer	Proceed to dismantle the hammer to replace the gaskets only or the whole piston as follows:

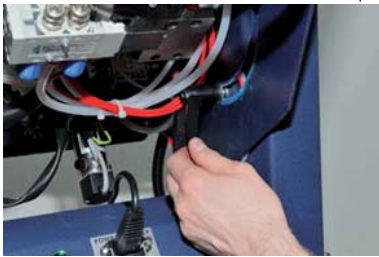

Loosen the knob to tilt the working bench.



Remove the screws which hold the pneumatic cylinder in place.

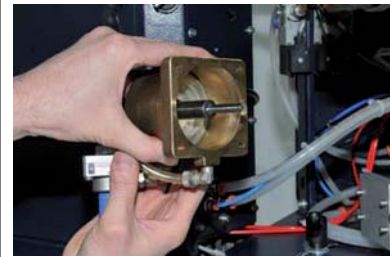

Remove the pneumatic cylinder and check the level of internal wear.



Replace the external flange seal.



Replace the internal flange seal.



Replace both piston seals. If the hammer is worn out, proceed to replace the whole piston.



on the left the U600 type, to the right the U500



Lubricate and reinstall the piston.



NB: align the hammer with the high part pointing towards the magazine.



Lubricate and reinstall the cylinder.

Once the operation has been completed, proceed to align the V-Nail firing unit, head, magazine, etc..



FREQUENCY	CHECK	METHODS AND RESULTS
Every 5,000,000 V-nails inserted	Check / replace the "L" support block	Proceed with disassembly by following the instructions in the heading MECHANICAL ADJUSTMENTS / MAINTENANCE
At least once a month	Inside of the casing - motor housing	All the parts inside the casings and in the machine housings where the motors are installed, must be kept clean and dry. Use suitable and normally available tools and equipment (e.g. vacuum cleaners and dry brushes to remove dust and absorbent cloths for removing moisture) to keep said areas of the machine in a suitable operating condition.
At least once a month	Check the effectiveness: <ul style="list-style-type: none"> <li>of the mechanical connections</li> </ul>	Use suitable tools and equipment to check the tightness of terminals, screws, nuts, bolts and connections in general on both the equipment and the machine.
At least once every 3 months	Check reliability and operation: <ul style="list-style-type: none"> <li>of the micro-switches and proximity switches;</li> <li>of the raceways and cables</li> </ul>	Carry out a visual inspection to ascertain the state of the solenoid valves, the microswitches and proximity sensors as well as the cable ducts and the wiring inside and outside the enclosures. If these, including single core and/or multicore cables, are not in perfect condition, they must be replaced in order to ensure correct operation. <b>Check the correct clearance of cams for the activation of microswitches.</b> If the cams are missing or are no longer in their original positions, stop the machine immediately and contact the machine manufacturer.
At least once every 3 months	General checks: <ul style="list-style-type: none"> <li>of the electrical equipment</li> </ul>	Check all the electrical equipment, electrical enclosure and systems on board the machine, to ensure continuity of service and correct operation. Also check the efficiency of all the visual and audible signalling devices belonging to the safety functions and the cycle functions of the equipment itself. Check all parts of the electrical equipment subject to wear, e.g.; <b>make sure all cables and all the command actuators activated by operators</b> are intact and in good working order. If this is not the case they must be replaced.
At least once every 3 months	Check reliability and operation: <ul style="list-style-type: none"> <li>of fixed guards</li> <li>of the safety devices.</li> </ul>	All guards, devices and circuits indicated must perform the function for which they were designed. Command the devices directly to make sure they activate the intended function/indication. Further useful indications on how to carry out checks and inspections are provided in the manuals accompanying the relative components supplied with the electrical equipment.  <b>The necessary inspections concern:</b> <ul style="list-style-type: none"> <li>loss or damage to any part of the safeguards, especially if this entails a reduction in the safety function it is designed to perform, for example a reduction in resistance to impact caused by scratches/damage to Plexiglas panels.</li> <li>replacement of wear parts;</li> <li>correct operation of interlocks;</li> <li>deterioration of joints or fixing points;</li> <li>deterioration due to corrosion, temperature variations or chemical effects;</li> <li>satisfactory operation and lubrication of moving parts, if necessary;</li> <li>modification of safety distances and size of openings;</li> <li>deterioration of the acoustic performance, if applicable.</li> </ul> Replacement must be carried out when one of the components indicated displays anomalous wear and at the first sign of cracking, erosion or breakage. Parts must always be replaced using original spare parts or at least parts which provide equivalent quality and safety . Contact the manufacturer directly.

FREQUENCY	CHECK	METHODS AND RESULTS
At least once every six months	<b>Check the effectiveness:</b> <ul style="list-style-type: none"> <li>of electrical insulation of the motors.</li> </ul>	Using suitable instruments the resistance of the insulation on the motors must be measured and checked to make sure that the measured values fall with the limits of acceptability defined by the installation standards and in accordance with the regulations in force in the place of installation.
At least once every six months	<b>Instrumental checks:</b> <ul style="list-style-type: none"> <li>power absorption in the individual phase conductors of users and motors.</li> </ul>	Use suitable instruments to measure the power absorption on each supply conductors of users and motors. If the values detected during normal machine operation do not fall within a 10% range of the values indicated in the power supply and command/control electrical diagrams, alert the maintenance service and get all the other characteristics of the user/motor checked as it may be on the point of breaking down.
At least once a year	<b>Check the effectiveness:</b> <ul style="list-style-type: none"> <li>of the connections and the electrical components inside and outside the enclosures.</li> </ul>	Check to ensure there are no loose connections. If any loose connections are found, tighten them with adequate torque as shown directly on the electrical components.  The check must also concern: <ol style="list-style-type: none"> <li>The good condition of the junction boxes, the enclosures, the pushbutton panels and the protective sheaths on the electrical cables</li> <li>Functionality of all control and power actuators.</li> </ol>

Parts must always be replaced using original spare parts or at least parts which provide equivalent quality and safety .  
THE INSTRUCTIONS CONCERNING THE REPLACEMENT ARE NOT GIVEN IN THIS MANUAL and they must therefore be explicitly requested from the machine manufacturer, which reserves the RESPONSIBILITY FOR THE REPLACEMENT INTERVENTIONS.

### 5.9. CLEANING

 **DANGER – CAUTION**  
*It is prohibited to manually clean, oil or grease moving machine parts and elements unless this is strictly necessary for some specific technical requirement. If this is the case all suitable measures must be taken to prevent hazards. Workers must be informed by means of clearly visible warning signs. Cleaning operations which can be performed by maintenance technicians are indicated below.*

Normally, some cleaning operations can be performed by the machine runner; i.e., in the case of normal operations on the outside of the machine that call for the use of simple personal protective equipment.  
Cleaning operations of the internal parts of the machine must be performed by the maintenance service.

To avoid inadvertent untimely and hazardous activation of the machine or unwanted and inadvertent modifications of any kind, cleaning operations should be carried out by the same personnel who usually work on the machinery rather than personnel from a cleaning company who may not observe all the recommendations indicated herein.

All cleaning operations must be carried out only after the machine has been cut off from external power supplies and all accumulated energy has been discharged.

 **DANGER – CAUTION**  
*Never use petrol, solvents or other inflammable and/or corrosive fluids to clean the machine, the electrical equipment or the machine components. Use exclusively commercial, approved non-flammable and non toxic solvents.*

Comply with the methods of use and use all the necessary personal protective equipment specified by the supplier of such substances.

The machine, its electrical equipment and its on-board components must never be washed with water, especially not in the form of jets of any type or intensity; i.e. it must not be washed using buckets, hoses, or even sponges.  
For the identification of the components mentioned and details on their position, refer to the “mechanical components” layout and the layout attached to the electrical diagram provided with the machine.

Fixed guards must be removed in order to gain access to some of the parts requiring lubrication.  
Fixed guards are identified by the following sign:



Once all cleaning operations have been completed, all the fixed guards must be refitted and secured in place.

### 5.9.1 CLEANING THE TOUCHSCREEN

The touchscreen is the sensitive part of the display which transmits commands to the system even when gloves are worn.

To guarantee optimum operation and sensitivity it is important to keep the touchscreen clean at all times and to avoid touching it with sticky fingers.

Daily cleaning of the touchscreen can be carried out by gently wiping the surface of the screen with a microfibre cleaning cloth, like the ones used to clean glasses.

If the screen is very dirty you may also use a damp cloth (with water) or buy a special detergent solution suitable for removing greasy marks from the screen.

To avoid irreparably damaging the touchscreen making it unusable, observe the following recommendations:

- DO NOT use chemical products, ammonia or alcohol- or other solvent-based detergents.
- DO NOT use scrapers or any metal tools.
- DO NOT use abrasive cloths or paper towels or tissue paper or paper napkins which could scratch the surface of the screen.
- NEVER use a lot of water. The microfibre cloth may only be slightly dampened.
- DO NOT push down on the screen too hard when cleaning it.
- Turn the screen off to clean it.

### 5.9.2 REPLACING THE PROTECTIVE FILM ON THE DISPLAY

- With the supplier check that the touchscreen is covered with a protective film.
- Use only genuine protective film to avoid changing the sensitivity of the touchscreen.
- Never use metal, pointed or sharp tools to remove the film as these may damage the screen.
- The protective film must be replaced by expert personnel as it is necessary to disassemble the display panel inside the metal casing.



### 5.10. LUBRICATION

During lubrication operations:

1. Avoid bringing oil and/or grease into contact with the skin.
2. During oil and/or grease changes use protective gloves.

Both spent and fresh lubricants are highly polluting: for disposal of lubricants consult your lubricant dealer or contact a specific toxic waste disposal company.

All lubrication operations must be performed:

1. after first cutting off all external energy supplies,
2. strictly observing the safety indications given in the "safety datasheets" provided with each individual lubrication product used.

The lubrication operations which must be performed by maintenance technicians are indicated below.

To obtain high performance and faultless operation, it is important to lubricate moving parts of the machine on a regular basis.

The position of machine components which need lubricating is shown in the layout provided as an appendix to this manual.

For the disposal of spent oil and grease, observe the relative legislation in force.

Do not disperse spent oil in the environment. Consign it to specifically authorised collection centres.

#### NOTES



- Fixed guards must be removed in order to gain access to some of the parts requiring lubrication.*
- Fixed guards are identified by the following sign:*

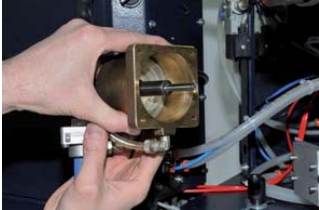

Once lubrication operations have been completed, all the fixed guards must be refitted and secured in place.

FREQUENCY	LUBRICATION	METHODS AND RESULTS
Every 200 service hours	Hammer piston	Lubricate the hammer piston by following the instructions provided in the heading ROUTINE MAINTENANCE.  

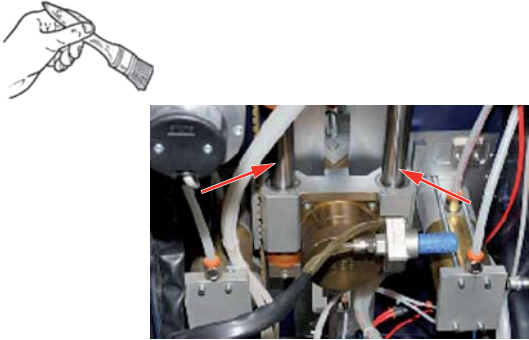

FREQUENCY	LUBRICATION	METHODS AND RESULTS
<p>At least once every six months</p>	<p>Carriage guides</p>	<p>Lubricate the carriage guides located under the working bench.</p>  <p>To gain access and perform lubrication the maintenance technician must:</p> <ol style="list-style-type: none"> <li>1. Isolate the machine from external power supplies.</li> <li>2. Remove the fixed guards when necessary.</li> <li>3. Using a brush, manually spread a layer of lubricant on the upper part of the sliding guides.</li> <li>4. Refit and secure the fixed guards.</li> </ol> <p><b>For lubrication, use SHELL grease.</b></p>
<p>When necessary</p>	<p>Pneumatic actuators</p>	<p>Automatic lubrication of the pneumatic actuators. Make sure there is oil in the reservoir of the filter unit.</p>  <p>Top up, if necessary, with CASTROL MAGNA GC 32 oil or equivalent.</p>

## 6. TROUBLESHOOTING AND RELEASE OF MOVING PARTS

If any of the moving parts becomes jammed, in order to release it in conditions of safety the machine operator must first stop the machine (also by pressing one of the emergency stop pushbuttons if present) and then inform the persons in charge of maintenance, if he has not been authorised to release jammed parts beforehand.

The following section describes operations for troubleshooting and releasing moving parts that can be performed by maintenance technicians.

Before performing any work or investigations:

1. Install a sign indicating that maintenance is in progress on the machine
2. Make sure that the upline and downline connected machines do not constitute a source of danger or an impediment to the maintenance work; switch off said machines using the designated procedures.
3. Before restarting the machine, make sure there are no personnel still performing cleaning and /or maintenance operations on it.
4. For electrical checks and minor repairs have the work performed exclusively by professional licensed electricians and/or electro-technicians with all the necessary authorisations.
5. For mechanical repair work, always seek the assistance of the manufacturer.
6. Always consult the machine manufacture in accordance with the methods specified on the initial pages of this manual.
7. Do not zero/reset the safety devices automatically by means of an external sequence without first checking and identifying the cause of the stoppage.

By observing any types of information that the machine control system provides, machine faults can be identified and interpreted. All information devices (visual, audible) aimed at avoiding potential ergonomic hazards, with the relative explanations and the type of information the operator/s will receive are described in chapters 3 and 4.

Depending on the type of information, action must be taken to eliminate the cause that led to/generated the visual or audible alarm signal.

The PROBLEMS OR FAULTS which could lead to a MACHINE STOPPAGE are:

PROBLEM / FAULT	POTENTIAL CAUSE(S)	METHODS AND ANCILLARY NOTES
Power loss	<p>General blackout.</p> <p>Tripping of the short circuit protection device or any other device upline of the electrical equipment power supply circuit</p> <p>Activation of an emergency stop device or a safety device</p>	<p>Contact the electricity provider.</p> <p>After having rectified the causes that led to tripping of the device in question, reset the device. It is advisable to open all the protection/interruption/disconnecting devices of the loads and then close them one at a time.</p>
Interruption of production	<p>Tripping of a protection device inside the electrical enclosure.</p> <p>Unidentifiable cause(s)</p> <p>Power loss.</p> <p>Disconnecting devices set to "OFF".</p>	<p>After having rectified the causes that led to tripping of the device in question, reset the device. It is advisable to open all the protection/interruption/disconnecting devices of the loads and then close them one at a time.</p> <p>After having rectified the causes that led to tripping of the device in question, reset the device. If fuses blow, replace them with the same model of fuse, identically rated and with the same delay curve. It is advisable to open all the protection and sectioning devices of the loads and then close them one at a time.</p> <p>Contact the manufacturer directly.</p>
The machine fails to operate	<p>One or more emergency/safety systems has tripped.</p> <p>Fuses blown or circuit breakers not working.</p>	<p>Check and restore electrical supply.</p> <p>Set sectioning devices to "ON".</p> <p>Reset emergency systems and check efficiency if necessary.</p> <p>Change blown fuses and check the status of the magnetothermal circuit breakers.</p>

PROBLEM / FAULT	POTENTIAL CAUSE(S)	METHODS AND ANCILLARY NOTES
Machine runs noisily.	Machine moving parts are not well lubricated.	Check for any jamming of moving parts and/or perform lubrication as required.
Motors fail to start	Power loss.  Disconnecting devices set to "OFF".  One or more emergency/safety systems has tripped.  Fuses blown or circuit breakers not working.	Check and restore electrical supply.  Turn sectioning devices to "ON".  Reset emergency systems and check efficiency if necessary.  Change blown fuses and check the status of the magnetothermal circuit breakers.

**Machine operating problems:**

PROBLEM / FAULT	POSSIBLE SOLUTIONS
Insufficient operating pressure	1. Check that the minimum pressure value for the system is over 3 Bar. 2. Check that the pressure value indicated on the gauge is 1.5-2 Bar.
Interruption of production	1. Check that the sharpened part (edge with glue) is pointing up. 2. Check the position of the V-nails and that the "V" of the nails is pointing towards the outside of the machine. 3. Check that the V-nails show no signs of faulty gluing, uneven profiles, etc., replace if necessary.
Insufficient thrust on the V-nails from the pusher	Check that the pressure of the reduction valve which supplies the V-nail pusher cylinder is at least 2 Bar. If necessary increase by 10%.
Faulty V-nails	1. Replace the V-nails 2. Use the V-nails in smaller sections
Faulty or clogged valves	1. Remove oil and/or condensate as described in point c. 2. Replace the pedal valve. 3. Replace the control valve.
Pedal valve or position valves blocked	Disconnect or replace the pedal valve.

---

## 7. REINSTALLATION AND REUSE

---

 **CAUTION - DANGER**  
**MOVING AND REINSTALLING THE MACHINE IN A DIFFERENT LOCATION ARE HIGHLY DELICATE OPERATIONS WHICH CALL FOR SIGNIFICANT EXPERIENCE. CONSEQUENTLY TO ENSURE THAT THE OPERATIONS ARE CARRIED OUT WITHOUT ANY RISKS FOR PERSONNEL OR THE MACHINE, THESE OPERATIONS MUST BE CARRIED OUT SOLELY AND EXCLUSIVELY BY PERSONNEL APPOINTED DIRECTLY BY THE MACHINE MANUFACTURER OR AUTHORISED BY THE SAME.**

---

## 8. EXTINGUISHING MEDIA

---

The indications on extinguishing media are of fundamental importance as any operations/interventions which are not carried out in compliance with the indications provided below or are not foreseen, may damage the machine, its internal components, the power supply system, the product being handled/produced not to mention injury to operators. Failure to observe the indications will also nullify the warranty.

 **CAUTION - DANGER**  
**ALL OPERATIONS TO PUT OUT A FIRE MUST BE CARRIED OUT BY PERSONNEL WHO ARE ADEQUATELY INFORMED AND TRAINED CONCERNING THE RISKS AND HAZARDS THAT MAY ARISE DURING EXECUTION OF SAID ACTIVITIES. THEY MUST HAVE READ AND UNDERSTOOD THE SAFETY PRESCRIPTIONS PROVIDED IN THIS INSTRUCTION MANUAL AND BE IN GOOD PSYCHO-PHYSICAL SHAPE.**

In the event of a fire affecting the electrical equipment, other parts of the machine, or the processed product, always use a type "C" CO<sub>2</sub> extinguisher.

A fire extinguisher of this type must be kept next to the machine work station at all times.

---

## 9. SCRAPPING AND DISPOSAL.

---

 **DANGER - WARNING**  
**IF YOU DECIDE NOT YOU NO LONGER WISH TO USE THE MACHINE DESCRIBED IN THIS MANUAL BECAUSE IT HAS BECOME OBSOLETE AND/OR IRREPARABLY DAMAGED OR WORN TO A POINT WHERE ANY FORM OF REPAIR WOULD NOT BE AN ECONOMICALLY VIABLE SOLUTION, IT MUST BE PUT OUT OF SERVICE AND RENDERED INOPERATIVE AND FREE FROM ALL POTENTIAL HAZARDS.**

Decommissioning of the machine must be carried out by specialised and suitably equipped personnel.

If the client does not have the right personnel or tools to be able to proceed with demolition of the machine in total safety and in such a way as to safeguard the operators involved, he must seek the assistance of the machine manufacturer's technical staff.

Before starting the scrapping procedures display signs informing persons in the area that work is in progress.

### 9.1. SCRAPPING

 **NOTES**  
*To be able to perform the necessary tasks in maximum safety, the areas around the machine, for a whole 360° and over a distance of at least 2000 mm, must be free of walls, other machinery, equipment or other elements, such as support pillars, which might get in the way.*

The main sequential stages for dismantling and scrapping include the following (the list is provided as a guideline and is not exhaustive): disassemble all machine components and consign them to an authority or company for differentiated collection in compliance with the relative legislation in force.

All operations to disconnect the machine must be carried out using suitable equipment and tools of an appropriate size (e.g. a flathead or Phillips screwdriver, hex wrenches, Allen keys, etc.), depending on the type of fasteners.

During dismantling procedures do not enter the interior of the machine or climb under or on top of it for any reason: always work while standing alongside the machine.

Before disassembling parts and/or disconnecting and/or loosening any joining elements, take steps to ensure that the connected parts cannot subsequently fall on top of yourself or other exposed persons.

This must be achieved also using ancillary supports or restraints, or approved and certified lifting devices in compliance with statutory legislation in force in your country.

Never carry out dismantling procedures single-handedly. Always make sure there is someone there to provide assistance and/or help in the event of accidents. Said assistant must have the professional training of a maintenance technician or higher.

Pay attention to any decals affixed to the components to be disconnected and next to terminal boxes.

When the machine has been fully dismantled all the identification plates of the machine and electrical equipment and all documents referring to the machine must be destroyed.



## 9.2. DISPOSAL

**⚠ DANGER - WARNING**  
**DISPOSE OF THE MACHINE COMPONENTS AND ALL IT ELECTRICAL EQUIPMENT IN ACCORDANCE WITH OPERATING METHODS WHICH OBSERVE THE MAIN REGULATIONS GOVERNING SAFETY AND ENVIRONMENTAL PROTECTION IN THE COUNTRY OF DISPOSAL.**

The machine can be disposed of without having to reduce it to small pieces; simply separate the main units it is made up of and load them onto a lorry for transfer to a scrap merchant.

Clearly, this operation must be performed using adequate lifting and handling equipment including forklifts, hoists, A-frames, overhead travelling cranes, etc., all of which must be approved and certified in compliance with statutory legislation and applicable regulations.

Proceed with disposal operations in accordance with the relative legislation in force by contacting the relative bodies and/or specialized waste disposal companies authorized to handle industrial machinery and/or waste disposal to make sure that all plastics, metal materials and electrical components which must be disposed of separately are duly sorted.

The employer must be aware of all the statutory legislation in force in the country of disposal and must operate in compliance with the relative provisions.

It is prohibited to dump the machine and its electrical equipment in environment. All violations are punishable by law.

### IDENTIFICATION DATA

#### MANUFACTURER

ALFAMACCHINE S.r.l.

Address

Via Selva, 23/25 - 47122 FORLI

Tel. +39 0543 783301 Fax +39 0543 783302

E-mail: customerservice@alfamacchine.com

Name general / commercial	<b>FRAME ASSEMBLING MACHINE</b>
Function	<b>ASSEMBLY OF FRAMES BY INSERTION OF METAL V-NAILS</b>
Model	U500-U600 (previous version MP - MC)
Type	
Serial number	
Year of manufacture	

### DOCUMENT

#### INSTRUCTIONS MANUAL

No. of volumes: 1

Date: 04/11/2015

Revision: 02

© Copyright 2011 - ALFAMACCHINE S.r.l.

Unless expressly authorized in writing by ALFAMACCHINE S.r.l., this manual nor any part of it, may be copied in any form, modified, transcribed, translated into any language, made available to third parties or in any way used in a manner which could have a negative impact on the interests of ALFAMACCHINE S.r.l..

**All violations of the foregoing prescriptions are subject to penalties in compliance with the law and the rules of copyright.**

### APPENDICES / ANNEXES

# PNEUMATIC DIAGRAM U500

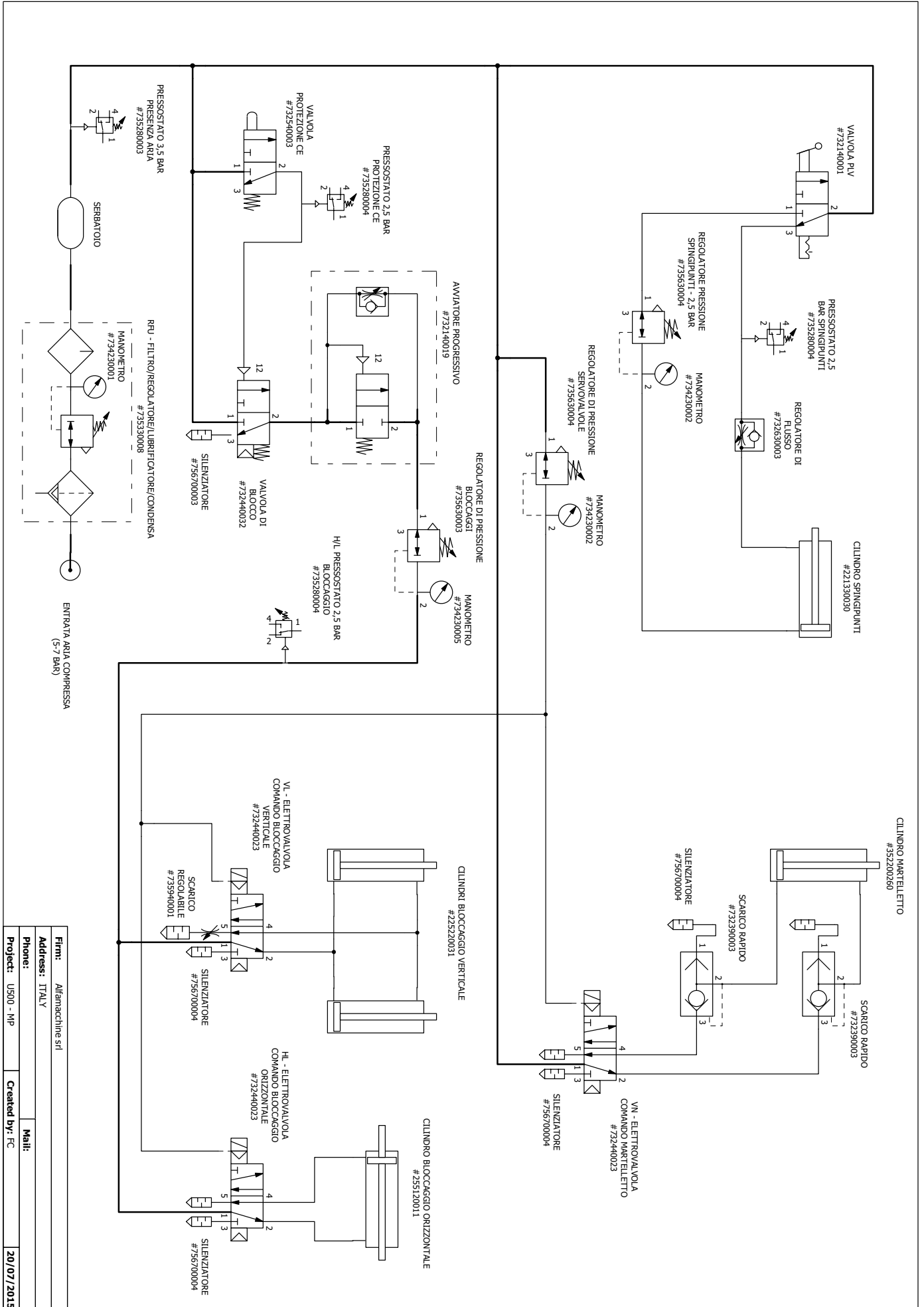

Firm:	Alfamacchine srl
Address:	ITALY
Phone:	
Project:	U500 - MP
Created by:	FC
Date:	20/07/2015

**PNEUMATIC DIAGRAM U600**

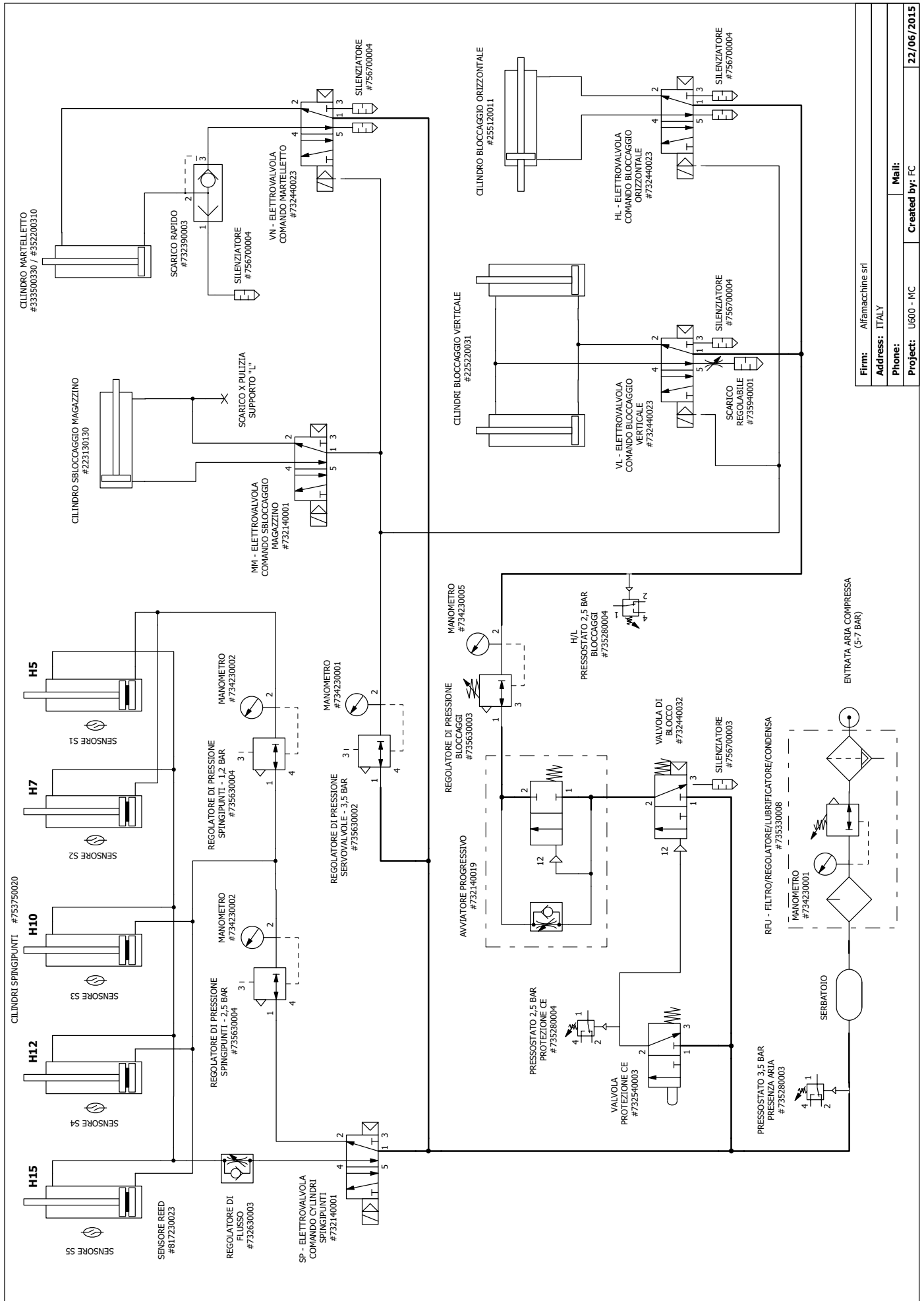

<b>Firm:</b> Alfamacchine srl
<b>Address:</b> ITALY
<b>Phone:</b>
<b>Project:</b> U600 - MC
<b>Created by:</b> FC
<b>Date:</b> 22/06/2015

**CAPS PNEUMATIC DIAGRAM**

**C.A.P.S.  
PNEUMATIC SCHEME MODIFICATION TO INSTALL THE ELECTRONIC PRESSURE REGULATOR  
FOR CLAMPING SYSTEM**

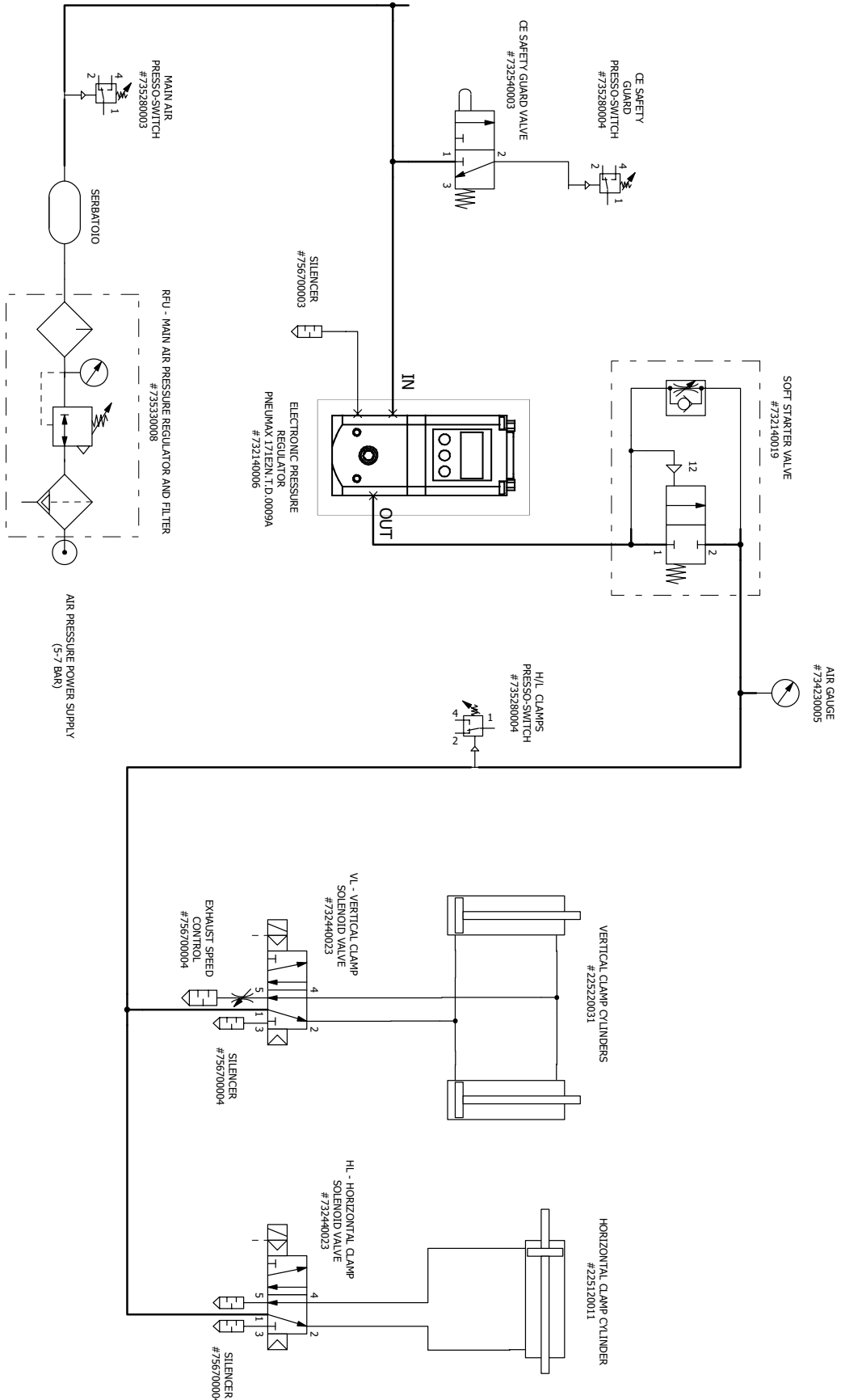

Firma:	Alfamacchine srl
Address:	ITALY
Phone:	
Project:	CAPS - U500/U600
Created by:	FC
	20/07/2015



**WIRING DIAGRAM U500**

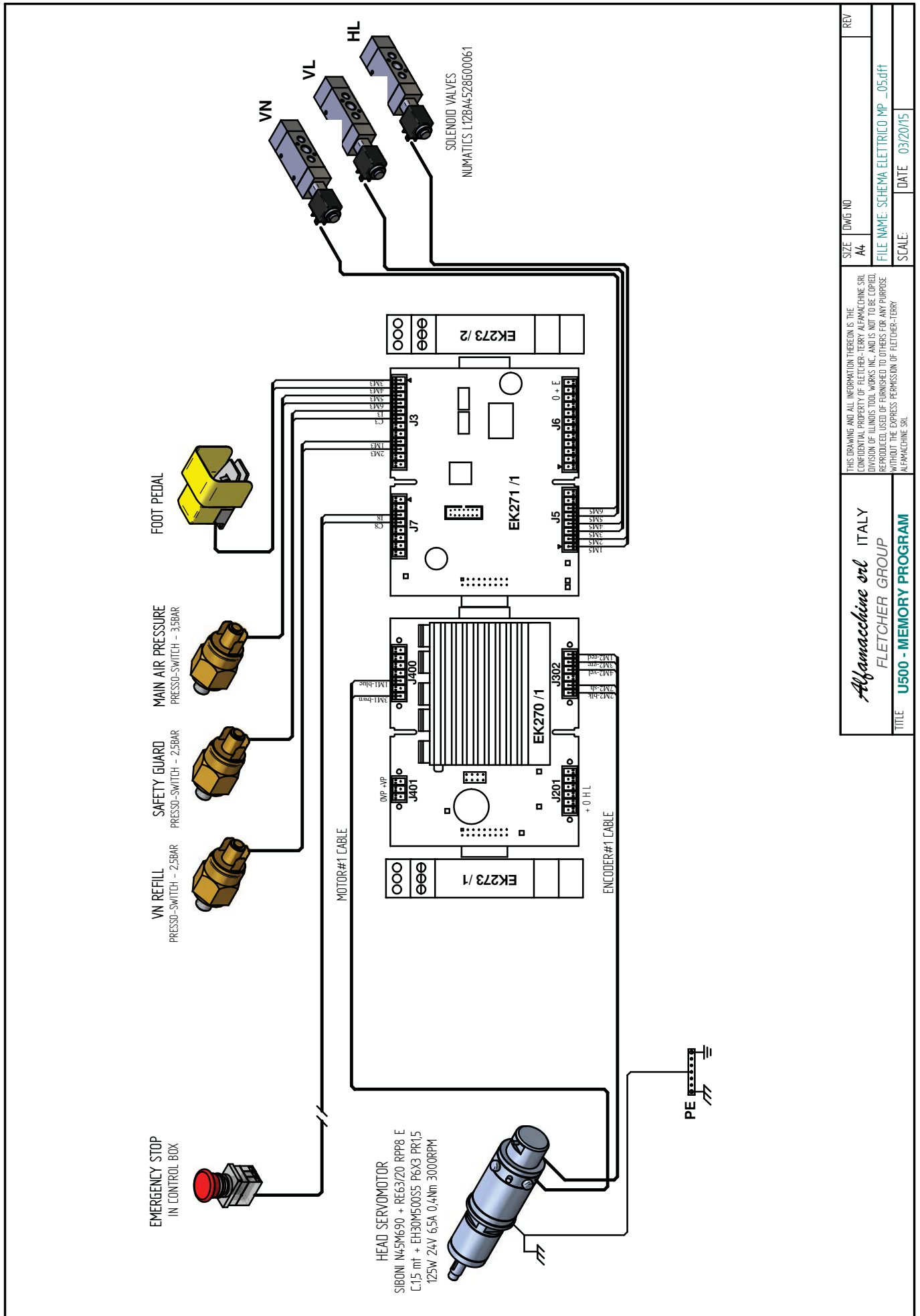

<p>THIS DRAWING AND ALL INFORMATION THEREON IS THE CONFIDENTIAL PROPERTY OF FLETCHER-TERRY ALFAMACCHINE SRL. DIVISION OF LUNIGIA TOOL WORKS INC. AND IS NOT TO BE COPIED, REPRODUCED, USED OR FURNISHED TO OTHERS FOR ANY PURPOSE WITHOUT THE EXPRESS PERMISSION OF FLETCHER-TERRY ALFAMACCHINE SRL.</p>	
<p>Alfamacchine srl FLETCHER GROUP</p>	<p>SIZE DWG NO A4</p>
<p>TITLE U500 - MEMORY PROGRAM</p>	<p>FILE NAME: SCHEMA ELETTRICO MP _05.dft</p>
<p>DATE 03/20/15</p>	<p>SCALE:</p>
<p>REV</p>	<p>REV</p>

**WIRING DIAGRAM U600**

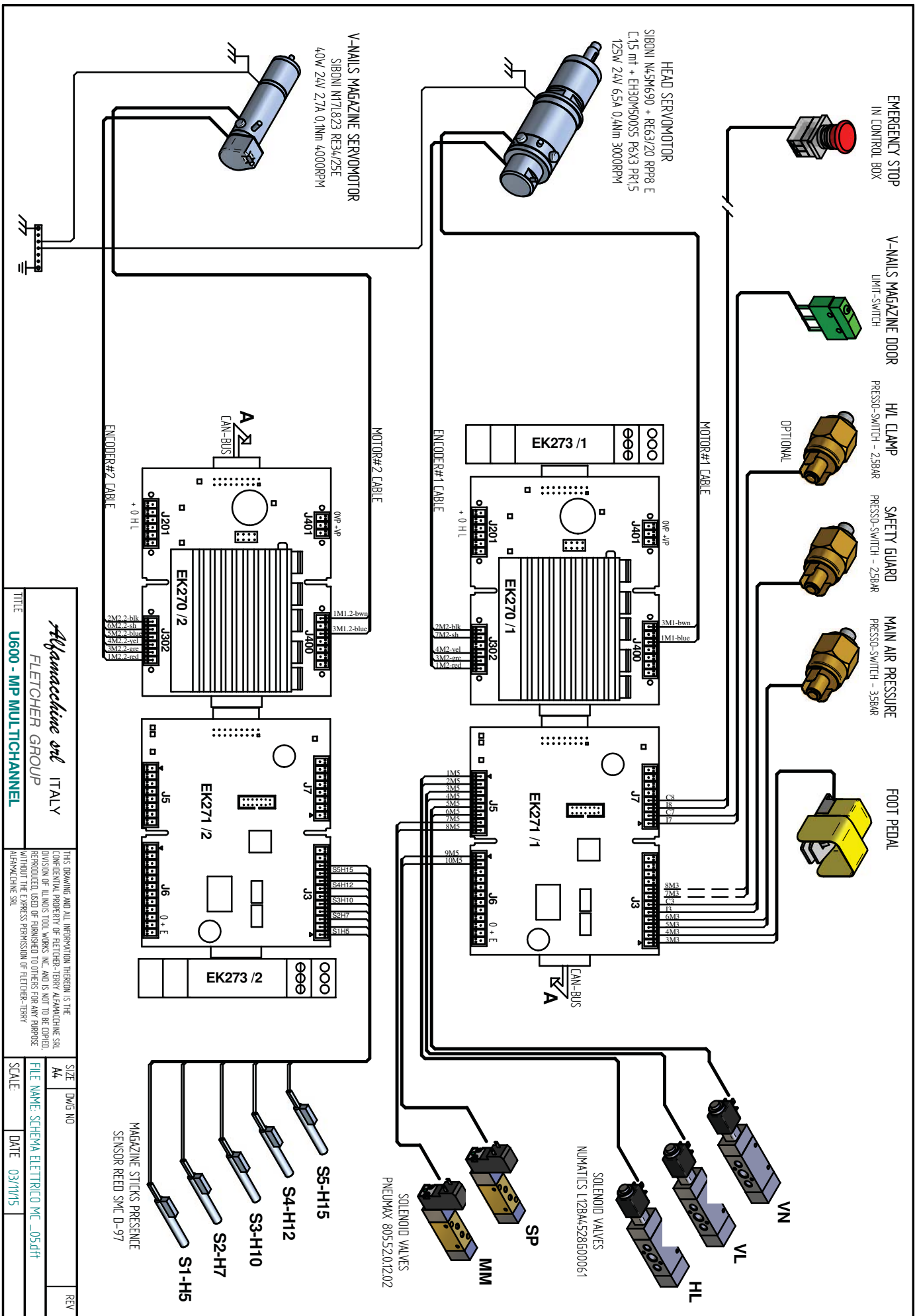

*Alfamacchine srl*  
FLETCHER GROUP  
ITALY

TITLE  
**U600 - MP MULTICHANNEL**

THIS DRAWING AND ALL INFORMATION THEREON IS THE CONFIDENTIAL PROPERTY OF FLETCHER-TERRY ALFAMACCHINE SRL. DIVISION OF ILLINOIS TOOL WORKS INC. AND IS NOT TO BE COPIED, REPRODUCED, USED OR FURNISHED TO OTHERS FOR ANY PURPOSE WITHOUT THE EXPRESS PERMISSION OF FLETCHER-TERRY ALFAMACCHINE SRL.

SIZE	DWG. NO.	REV.
A4		
FILE NAME	SCHEMA ELETTRICO MC_05.dft	
SCALE	DATE	03/11/15

**CAPS WIRING DIAGRAM**

**U500/MP - U600/MC - AUTOMATIC AIR PRESSURE REGULATOR  
ELECTRICAL CONNECTIONS**

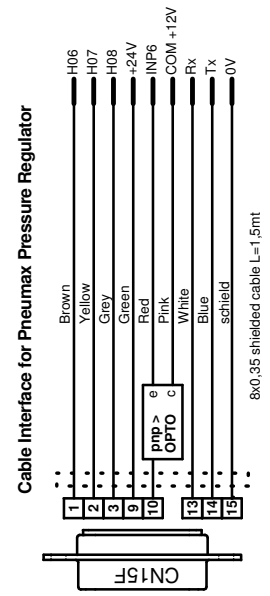
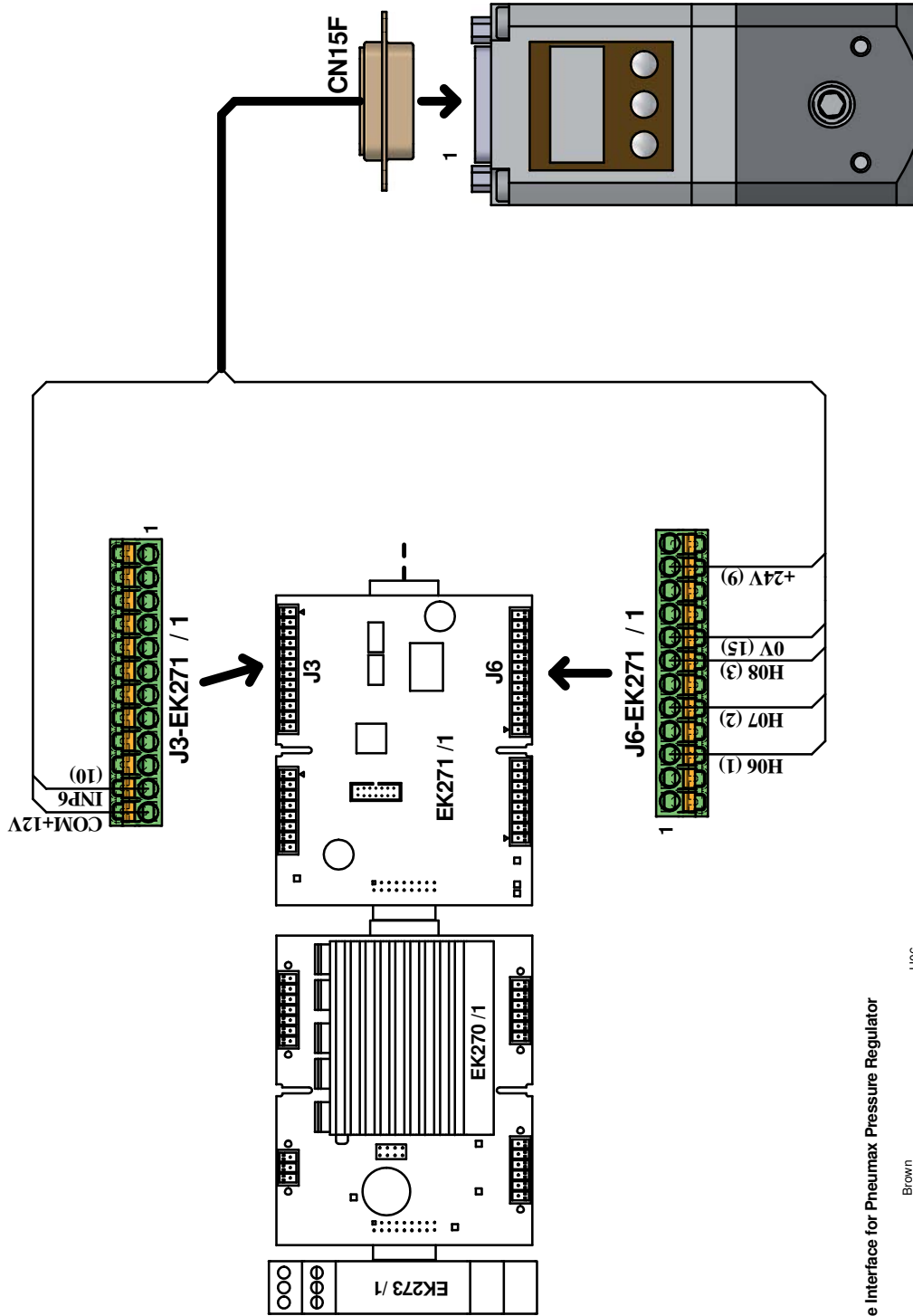

**PNEUMAX  
171E2N.T.D.0009A**

<p><i>Alfamacchine srl</i> ITALY FLETCHER GROUP</p>		<p>SIZE   DWG NO A4</p>	<p>DATE   03/11/15</p>
<p>TITLE   CAPS</p>		<p>SCALE:</p>	
<p>THIS DRAWING AND ALL INFORMATION THEREON IS THE CONFIDENTIAL PROPERTY OF FLETCHER-TERRY ALFAMACCHINE SRL DIVISION OF ILLINOIS TOOL WORKS, INC. AND IS NOT TO BE COPIED, REPRODUCED, USED OR FURNISHED TO OTHERS FOR ANY PURPOSE WITHOUT THE EXPRESS PERMISSION OF FLETCHER-TERRY ALFAMACCHINE SRL.</p>			
<p>FILE NAME: SCHEMA ELETTRICO MC _05.dft</p>		<p>REV</p>	

**EXPLODED-VIEW DRAWINGS U600-U500**

Numero oggetto	Numero documento	Commenti	Quantità
2*		HORIZONTAL CLAMP CYLINDER CILINDRO BLOCCAGGIO ORIZZONTALE - 225120011	1
4*		HORIZONTAL CLAMP SUPPORT SUPPORTO BLOCCAGGIO ORIZZONTALE - 384200020	2
5*		VERTICAL CLAMP CYLINDER CILINDRO BLOCCAGGIO VERTICALE - 225220031	2
6*		3 KNOBS/FENCES SQUADRA A 3 PUNELLI - 243160030	1
7*	TAB.2	CONFIGURABLE EMAGAZINE GROUP ASSEMBLY MONTAGGIO GRUPPO MAGAZZINO CONFIGURABILE	1
8*	TAB.3	MAGAZINE MOTOR GROUP ASSEMBLY MONTAGGIO GRUPPO MOTORE MAGAZZINO	1
9*	TAB.4	MAGAZINE SLIDE GROUP ASSEMBLY MONTAGGIO GRUPPO SLITTA MAGAZZINO	1
10*	TAB.5	HEAD GROUP ASSEMBLY MONTAGGIO GRUPPO TESTA	1
11*	TAB.6	HEAD MOTOR GROUP ASSEMBLY MONTAGGIO GRUPPO MOTORE TESTA	1
12*	TAB.7	MAGAZINE PROTECTION ASSEMBLY MONTAGGIO PROTEZIONE MAGAZZINO	1
13*	TAB.10	VERTICAL CLAMP GROUP ASSEMBLY GRUPPO BLOCCAGGIO VERTICALE	1
14*	TAB.12	CE SAFETY GUARD PROTECTION COMPLETE PROTEZIONE CE COMPLETA - 248960010	1
18		LEFT SIDE PANEL CHIUSSURA LATERALE CARCASSA 391600540	1
19		SOLENOID VALVES SUPPORT STAFFA PIGNA ELETTROVALVOLE - 384400100	1
21		BACK SIDE CASSETTE MC FRAME CARRIER SPRING UNIT MC - 291880050	1
22	TAB.8	FRONTAL CLAMP ASTA A FOGLIA BLOCCAGGIO ORIZZONTALE - 242170120	1
23		KNOB D.33 POMELLO 30 - 753320001	1
24		AIR PRESSURE GAUGE MANOMETRO - 288310040	1
26		METAL FRAME CARCASSA - 29177010	1
28		UNO TOP BENCH PIANO DI LAVORO U600 - 391250390	1

U600 TAB.0 MACHINE ASSEMBLY EXPLODED VIEW - VISTA ESPLOSO DELLA MACCHINA

Alfamacchine  
10.2015



Alfamacchine  
10.2015

U500 TAB.1 MACHINE ASSEMBLY EXPLODED VIEW - VISTA ESPLOSO DELLA MACCHINA

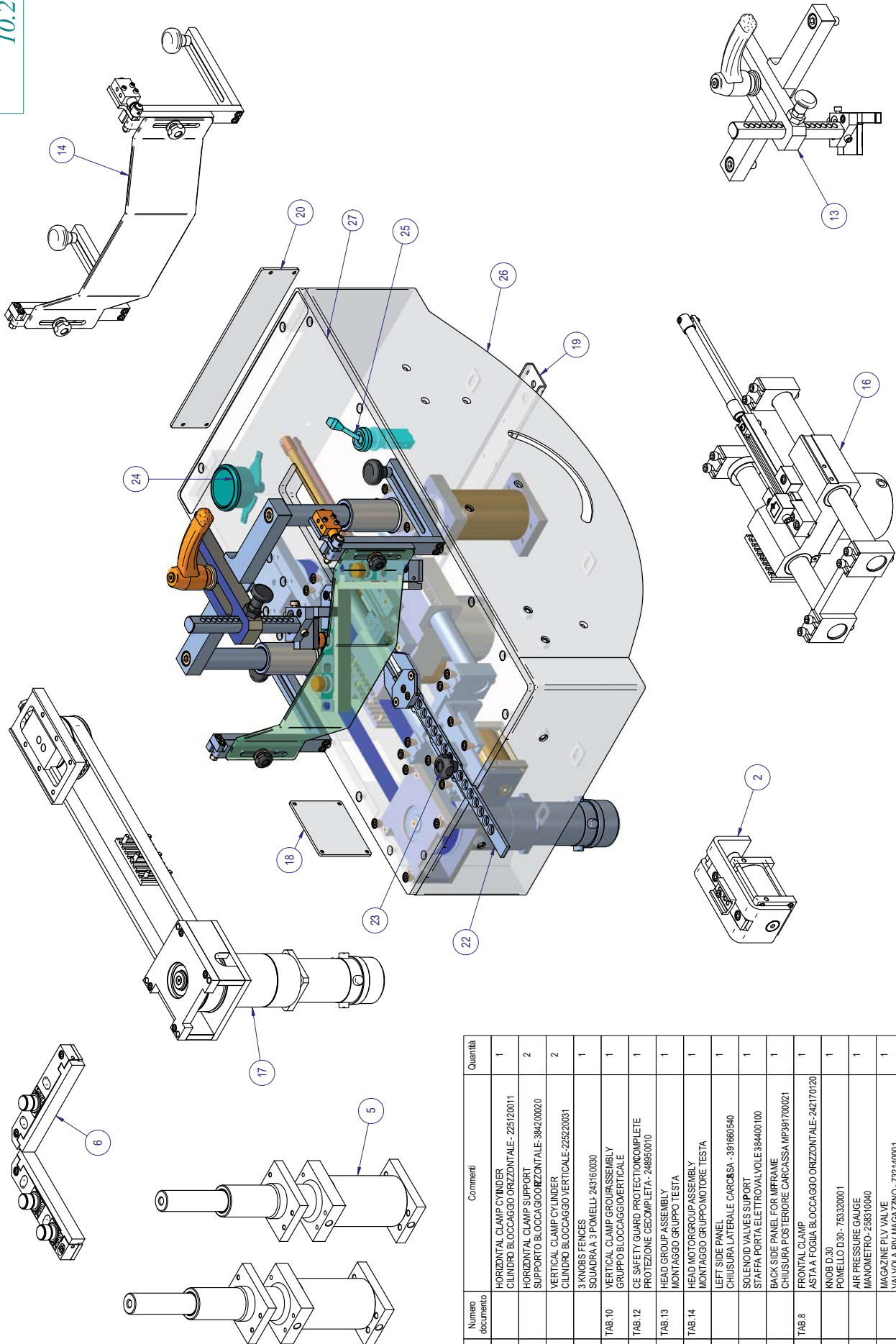

Numero oggetto	Numero documento	Commenti	Quantità
2*		HORIZONTAL CLAMP CYLINDER CILINDRO BLOCCAGGIO ORIZZONTALE - 225120011	1
4*		HORIZONTAL CLAMP SUPPORT SUPPORTO BLOCCAGGIO ORIZZONTALE - 384200020	2
5*		VERTICAL CLAMP CYLINDER CILINDRO BLOCCAGGIO VERTICALE - 225220031	2
6*		3 KNOBS FENCES SQUADRA A 3 PANNELLI - 243160030	1
13*	TAB.10	VERTICAL CLAMP GROUP ASSEMBLY GRUPPO BLOCCAGGIO VERTICALE	1
14*	TAB.12	CE SAFETY GUARD PROTECTION COMPLETE PROTEZIONE CE COMPLETA - 248850010	1
16*	TAB.13	HEAD GROUP ASSEMBLY MONTAGGIO GRUPPO TESTA	1
17*	TAB.14	HEAD MOTOR GROUP ASSEMBLY MONTAGGIO GRUPPO MOTORE TESTA	1
18		LEFT SIDE PANEL CHIUSURA LATERALE CARCASSA - 391600540	1
19		SOLENOID VALVES SUPPORT STAFFA PORTA ELETTROVALVOLE 384400100	1
20		BACK SIDE PANEL FOR MIFRAME CHIUSURA POSTERIORE CARCASSA MP391700021	1
TAB.8		FRONTAL CLAMP ASTA A FOGGIA BLOCCAGGIO ORIZZONTALE - 242170120	1
23		KNOB D.30 POMELLO D.30 - 753320001	1
24		AIR PRESSURE GAUGE MANOMETRO - 258510040	1
25		MAGAZINE PLY VALVE VALVOLA PV MAGAZZINO - 732140001	1
26		METAL FRAME CARCASSA - 291710010	1
27		U500 TOP BENCH PIANO DI LAVORO U500 - 391250191	1

U600 TAB.2 MAGAZINE GROUP - GRUPPO MAGAZZINO

Alfamacchine  
10.2015

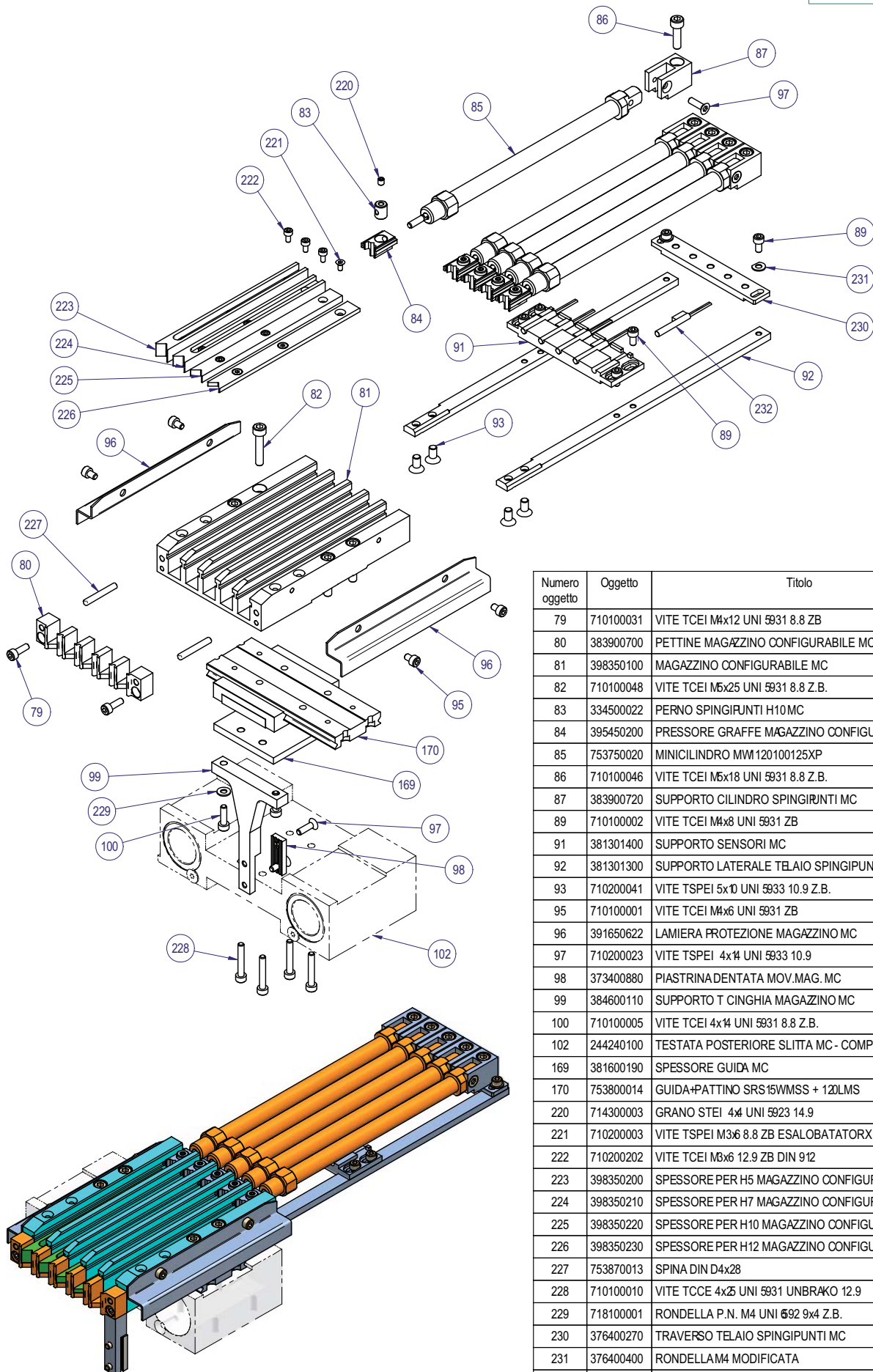

Numero oggetto	Oggetto	Titolo	Quantità
79	710100031	VITE TCEI M4x12 UNI 5931 8.8 ZB	2
80	383900700	PETTINE MAGAZZINO CONFIGURABILE MC	1
81	398350100	MAGAZZINO CONFIGURABILE MC	1
82	710100048	VITE TCEI M5x25 UNI 5931 8.8 Z.B.	4
83	334500022	PERNO SPINGIPUNTI H10 MC	5
84	395450200	PRESSORE GRAFFE MAGAZZINO CONFIGURABILE MC	5
85	753750020	MINICILINDRO MW120100125XP	5
86	710100046	VITE TCEI M5x18 UNI 5931 8.8 Z.B.	5
87	383900720	SUPPORTO CILINDRO SPINGIPUNTI MC	5
89	710100002	VITE TCEI M4x8 UNI 5931 ZB	6
91	381301400	SUPPORTO SENSORI MC	1
92	381301300	SUPPORTO LATERALE TELAIO SPINGIPUNTI MC	2
93	710200041	VITE TSPEI 5x10 UNI 5933 10.9 Z.B.	4
95	710100001	VITE TCEI M4x6 UNI 5931 ZB	4
96	391650622	LAMIERA PROTEZIONE MAGAZZINO MC	2
97	710200023	VITE TSPEI 4x14 UNI 5933 10.9	7
98	373400880	PIASTRINA DENTATA MOV.MAG. MC	1
99	384600110	SUPPORTO T CINGHIA MAGAZZINO MC	1
100	710100005	VITE TCEI 4x14 UNI 5931 8.8 Z.B.	2
102	244240100	TESTATA POSTERIORE SLITTA MC - COMPLETA	1
169	381600190	SPESSORE GUIDA MC	1
170	753800014	GUIDA+PATTINO SRS'15WMSS + 120LMS	1
220	714300003	GRANO STEI 4# UNI 5923 14.9	5
221	710200003	VITE TSPEI M3x6 8.8 ZB ESALOBATORX	3
222	710200202	VITE TCEI M3x6 12.9 ZB DIN 912	9
223	398350200	SPESSORE PER H5 MAGAZZINO CONFIGURABILE MC	1
224	398350210	SPESSORE PER H7 MAGAZZINO CONFIGURABILE MC	1
225	398350220	SPESSORE PER H10 MAGAZZINO CONFIGURABILE MC	1
226	398350230	SPESSORE PER H12 MAGAZZINO CONFIGURABILE MC	1
227	753870013	SPINA DIN D4x28	2
228	710100010	VITE TCCE 4x25 UNI 5931 UNBRAKO 12.9	4
229	718100001	RONDELLA P.N. M4 UNI 692 9x4 Z.B.	2
230	376400270	TRAVERSO TELAIO SPINGIPUNTI MC	1
231	376400400	RONDELLA M4 MODIFICATA	2
232	817230023	REED SENSOR SMC D-97	5

U600 TAB.3 MAGAZINE MOTOR GROUP - GRUPPO MOTORE MAGAZZINO

*Alfamacchine*  
10.2015

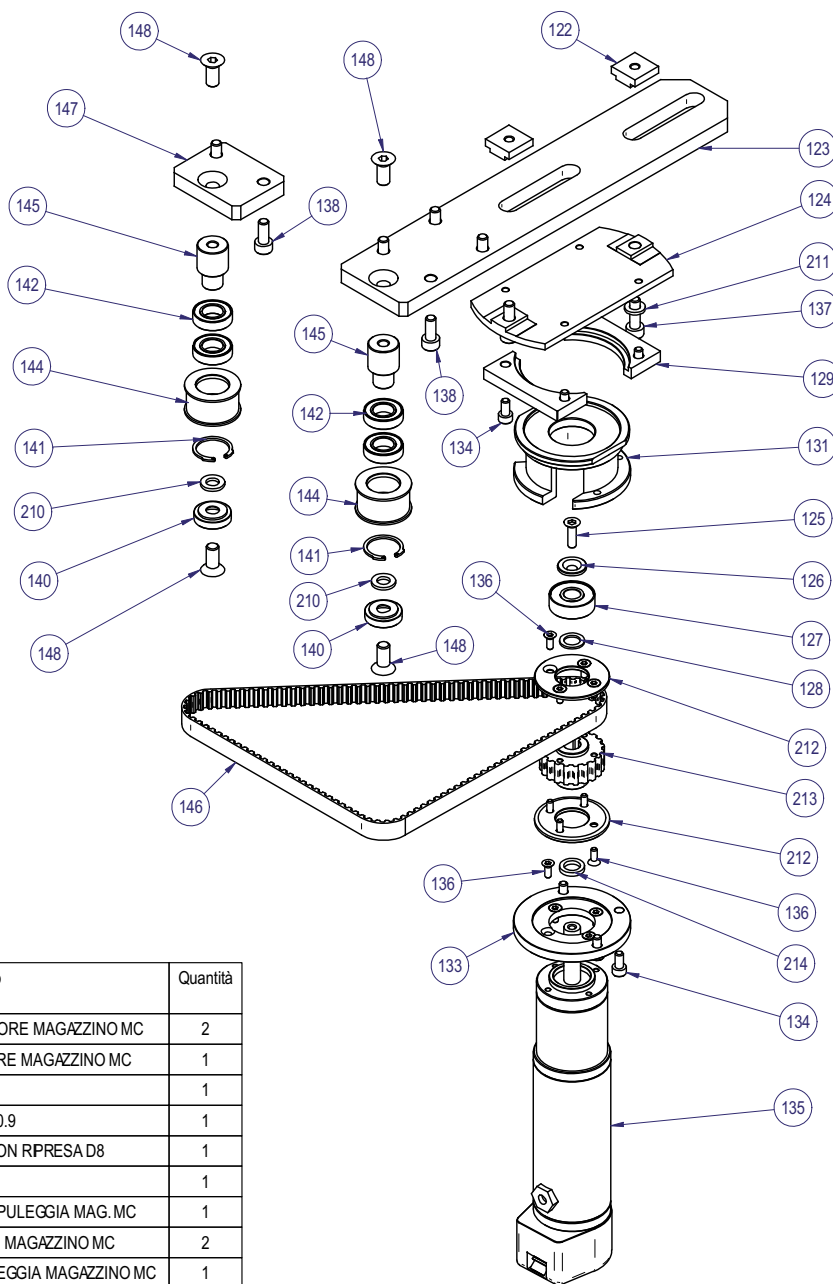

Numero oggetto	Oggetto	Titolo	Quantità
122	373400900	PIASTRINA FISSAGGIO MOTORE MAGAZZINO MC	2
123	373400850	PIASTRA SOSTEGNOMOTORE MAGAZZINO MC	1
124	384600121	PIASTRA CAMPANA MC	1
125	710200023	VITE TSPEI 4x14 UNI 533 10.9	1
126	336100810	RONDELLA D 14 SVASATA CON RPRESA D8	1
127	740550075	CUSCINETTO SKF 608 2RS1	1
128	337500660	DISTANZIALE CUSCINETTO PULEGGIA MAG. MC	1
129	388200290	STAFFA CAMPANA MOTORE MAGAZZINO MC	2
131	352600070	COPERCHIO CAMPANA PULEGGIA MAGAZZINO MC	1
133	338490090	FLANGIA CAMPANA MC	1
134	710100002	VITE TCEI M4x8 UNI 5931 ZB	6
135	807700190	MOTORE SBONI N17L823+RE34/25 DA8x28 E+EH17M500Z5P6x3PR1,5	1
136	710200002	VITE TSPEI 3 x 8 UNI 5933 10.9	12
137	710100062	VITE TCEI M5x16 UNI 5931 8.8 Z.B.	2
138	710100043	VITE TCEI M5x12 UNI 5931 8.8 Z.B.	6
140	336100750	RONDELLA D. 8 SVASATA MC	2
141	705050018	SEEGER PER FORO JV 19	2
142	740550069	CUSCINETTO SKF 61800 2RS	4
144	336000200	PULEGGIAFOLLE D27 MC	2
145	334500370	PERNO D15 PULEGGIA FOLLE MAGAZZINO MC	2
146	753860002	CINGHIA DENTATA T5x525-390T-H10	1
147	373400910	PIASTRA SPPORTO PULEGGIA MC	1
148	710200068	VITE TSPEI 6 x 14 UNI 533 10.9	4
210	718100003	RONDELLA PIANA M6 UNI 6592 12.5x6 Z.B.	2
211	718100002	RONDELLA PIANA M5 UNI 6592 5x10 Z.B.	1
212	381301390	ALETTA PULEGGIA T5 MC	2
213	336000210	PULEGGIA MOTORE T5 Z20 MC	1
214	337500661	DISTANZIALE CUSCINETTO PULEGGIA MAG. MC	1

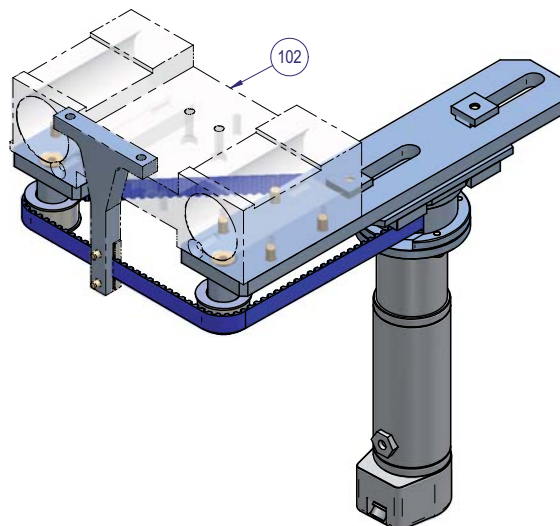

U600 TAB.4 MAGAZINE SLIDE GROUP - GRUPPO SLITTA MAGAZZINO

Alfamacchine  
10.2015

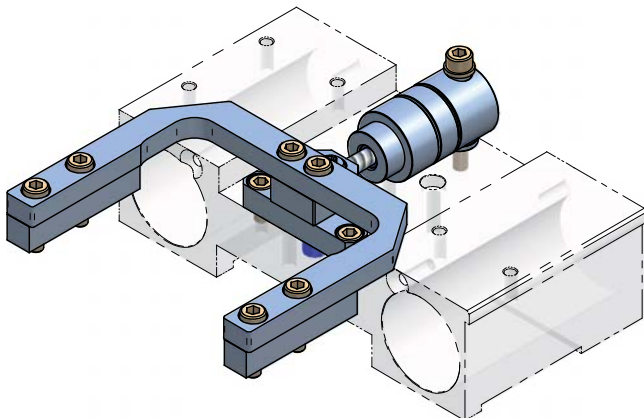
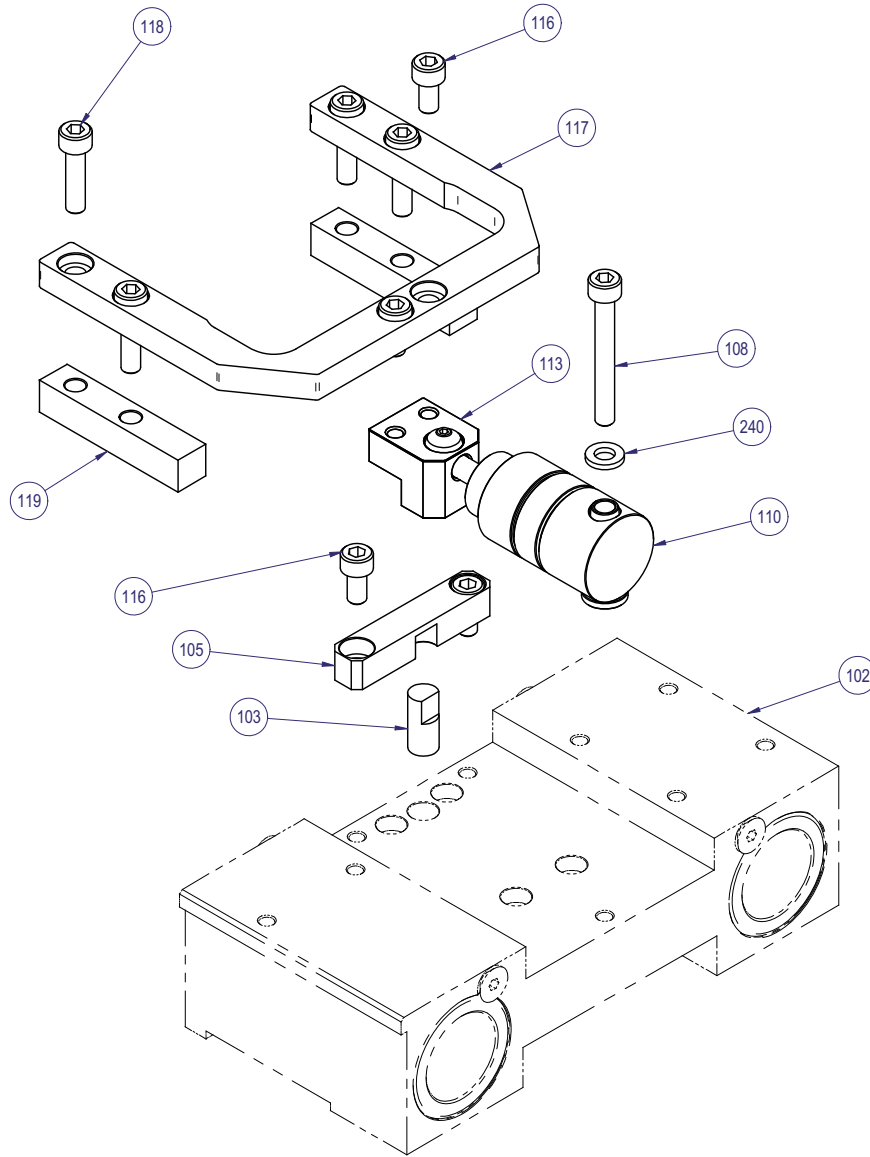

Numero oggetto	Oggetto	Titolo	Quantità
102	244240100	TESTATA POSTERIORE SLITTA MG COMPLETA	1
103	362810120	TONDO D.8x17 IN VULKOLLAN	1
105	383900730	SUPPORTO GUIDA SENSORI MAGAZZINOMC	1
108	710100065	VITE TCEI M5x40 UNI 5931 8.8 Z.B.	1
110	223130130	CILINDRO SLITTA MC	1
113*	397450050	ATTACCO ANT. CIL. SLITTA MC	1
116	710100042	VITE TCEI M5x10 UNI 5931 8.8 Z.B.	4
117	384400111	SUPPORTO "C" CILINDRO BILANCIAMENTO MAGAZ. MC	1
118	710100047	VITE TCEI M5x20 UNI 5931 8.8 Z.B.	4
119	381600201	SPESSORE SUPPORTO "C" MAGAZZINO MC	2
240	718100002	RONDELLA PIANA M5 UNI 6592 5x10 Z.B.	1



U600 TAB.5 HEAD GROUP - GRUPPO TESTA

*Alfamacchine*  
10.2015

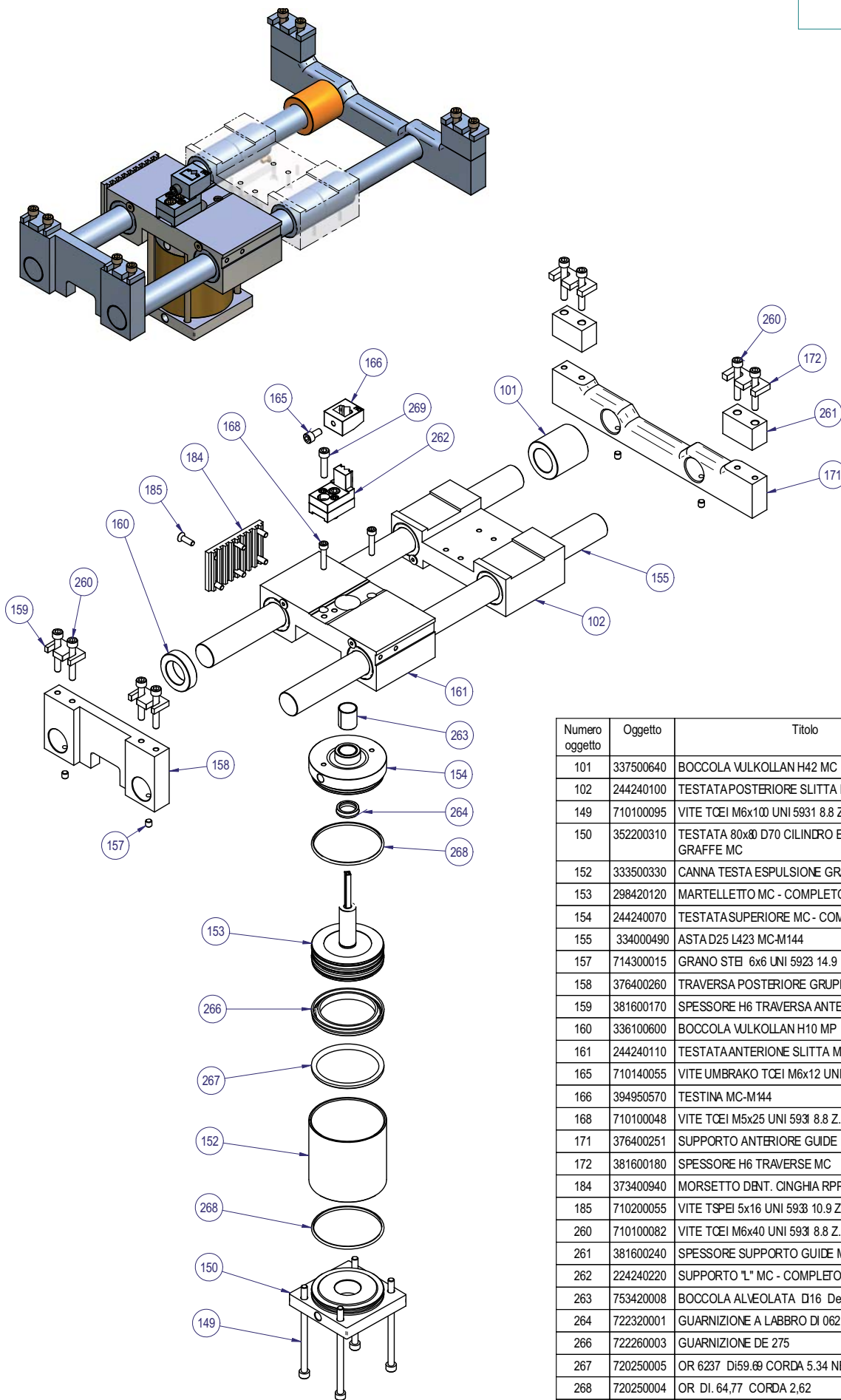

Numero oggetto	Oggetto	Titolo	Quantità
101	337500640	BOCCOLA VULKOLLAN H42 MC	1
102	244240100	TESTATAPOSTERIORE SLITTA MC - COMPLETA	1
149	710100095	VITE TCEI M6x100 UNI 5931 8.8 Z.B.	4
150	352200310	TESTATA 80x80 D70 CILINDRO ESPULSIONE GRAFFE MC	1
152	333500330	CANNA TESTA ESPULSIONE GRAFFE MC	1
153	298420120	MARTELLETTO MC - COMPLETO	1
154	244240070	TESTATA SUPERIORE MC - COMPLETA	1
155	334000490	ASTA D25 L423 MC-M144	2
157	714300015	GRANO STEI 6x6 UNI 5923 14.9	4
158	376400260	TRAVERSA POSTERIORE GRUPPO TESTA MC	1
159	381600170	SPESSORE H6 TRAVERSA ANTERIORE MC	2
160	336100600	BOCCOLA VULKOLLAN H10 MP	1
161	244240110	TESTATA ANTERIORE SLITTA MC - COMPLETA	1
165	710140055	VITE UMBRAKO TCEI M6x12 UNI 5931 NERA	1
166	394950570	TESTINA MC-M144	1
168	710100048	VITE TCEI M5x25 UNI 5931 8.8 Z.B.	2
171	376400251	SUPPORTO ANTERIORE GUIDE MC	1
172	381600180	SPESSORE H6 TRAVERSE MC	2
184	373400940	MORSETTO DENT. CINGHIA RPP8 MP-MC	1
185	710200055	VITE TSPEI 5x16 UNI 5931 10.9 ZB	6
260	710100082	VITE TCEI M6x40 UNI 5931 8.8 Z.B.	8
261	381600240	SPESSORE SUPPORTO GUIDE MC	2
262	224240220	SUPPORTO "L" MC - COMPLETO	1
263	753420008	BOCCOLA ALVEOLATA D16 De18 L20	1
264	722320001	GUARNIZIONE A LABBRIO DI 062	1
266	722260003	GUARNIZIONE DE 275	1
267	720250005	OR 6237 Di59.69 CORDA 5.34 NBR70	1
268	720250004	OR DI. 64.77 CORDA 2,62	2
269	710100105	VITE TCEI M6x25 UNI 5931 8.8 Z.B.	2

U600 TAB.6 HEAD MOTOR GROUP - GRUPPO MOTORE TESTA

Alfamacchine  
10.2015

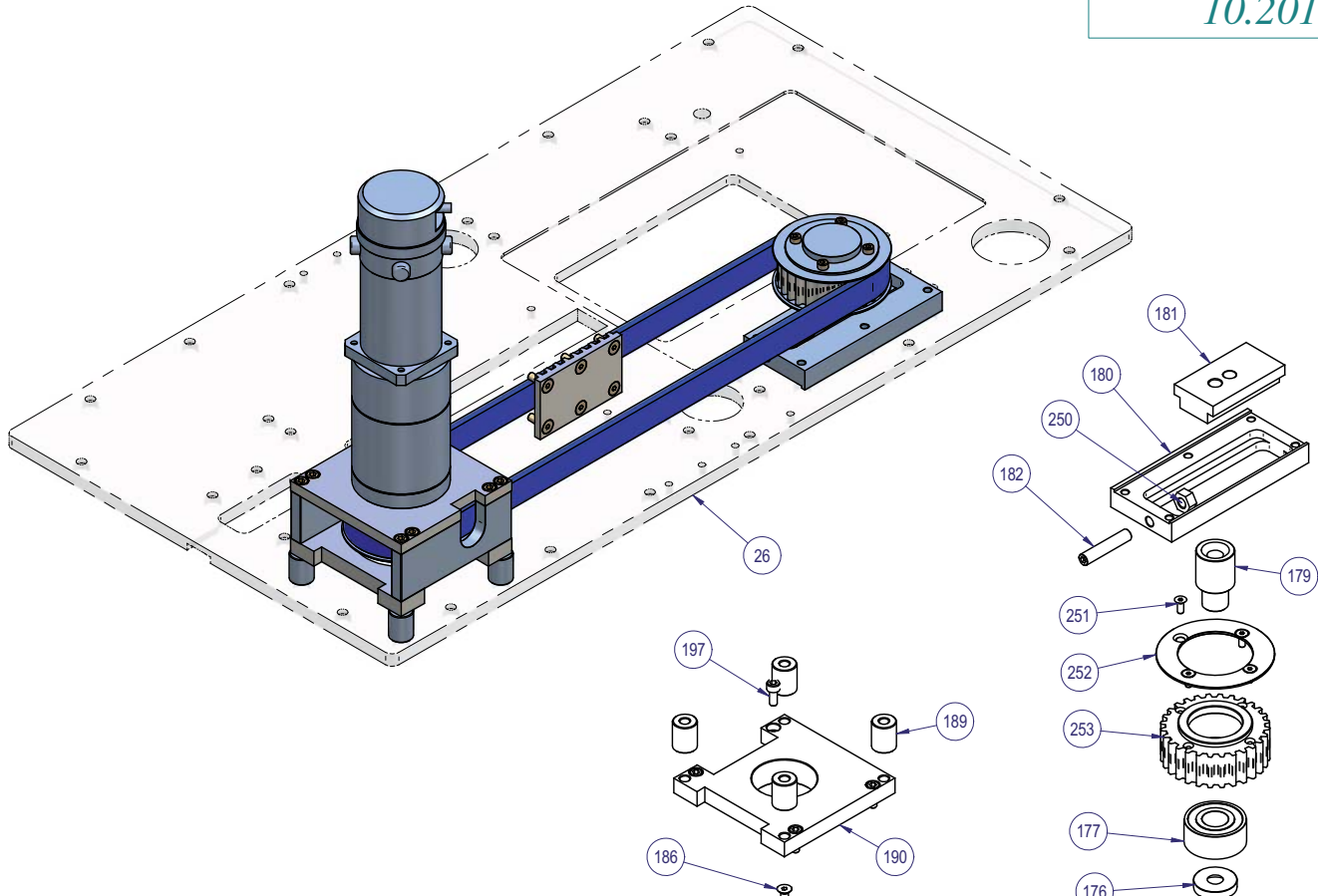

Numero oggetto	Oggetto	Titolo	Quantità
12*	LINGUETTA 5x5x24	LINGUETTA 5x5x24	1
26*	391250360	PIANO MC	1
173	710100003	VITE TCEI 4x10 UNI 5931 8.8 Z.B.	4
174	352600080	COPERCHIO PULEGGIA FOLLE RPP8 MP-MC	1
175	710200107	VITE VITE SPEI 10X60 NERA UNI 5933 10.9	1
176	336100010	RONDELLA PULEGGIA OZIOSA MP-MC	1
177	740550031	CUSCINETTO SKF 3203 2RS	1
179	334500380	PERNO D25 TENDICINGHIA MC	1
180	381201321	SUPPORTO BLOCCAGGIO TENDICINGHIA MC	1
181	384600091	SUPPORTO SCORREVOLE TENDICINGHIA MC-MP	1
182	714300050	GRANO STEI 8x40 UNI 5923 14.9	1
183	753660036	CINGHIA DENTATA 1000 RPP8 H20	1
184	373400940	MORSETTO DENT. CINGHIA RPP8 MP-MC	1
185	710200055	VITE TSPEI 5x16 UNI 5933 10.9 ZB	6
186	710200056	VITE TSPEI 5x14 UNI 5933 10.9 ZB	5
187	336100380	RONDELLA SCATOLA MOTORE MC-MP	1
188	740550035	CUSCINETTO SKF 6302 2RS	1
189	337500650	DISTANZIALE D16L20 MOTORE MC	4
190	352600091	COPERCHIO MOTORE MP-MC	1
191	710100031	VITE TCEI M4x12 UNI 5931 8.8 ZB	6
192	339000010	CALETTATORE PULEGGIA MOTORE MP-MC	1
194	381301420	FIANCO SCATOLA MOTORE MP-MC	2
196	381301410	SUPPORTO MOTORE MP RPP8 - RE63	1
197	710100043	VITE TCEI M5x12 UNI 5931 8.8 Z.B.	12
200	807650090	Motore SIBONI N45M690 + RE63 i20 RPP8 E C.1,5mt - CABLATO	1
250	715650004	DADO M8 MEDIO UNI 5988 6S P.G.ZB	1
251	710200021	VITE TSPEI 4x10 UNI 5933 10.9 ZB	12
252	381301430	ALETTA PULEGGIA RPP8 MP-MC	3
253	336000250	PULEGGIA FOLLE TENDICINGHIA MP-MC RPP8 Z8	1
254	336000260	PULEGGIA MOTORE MP-MC RPP8 Z8	1

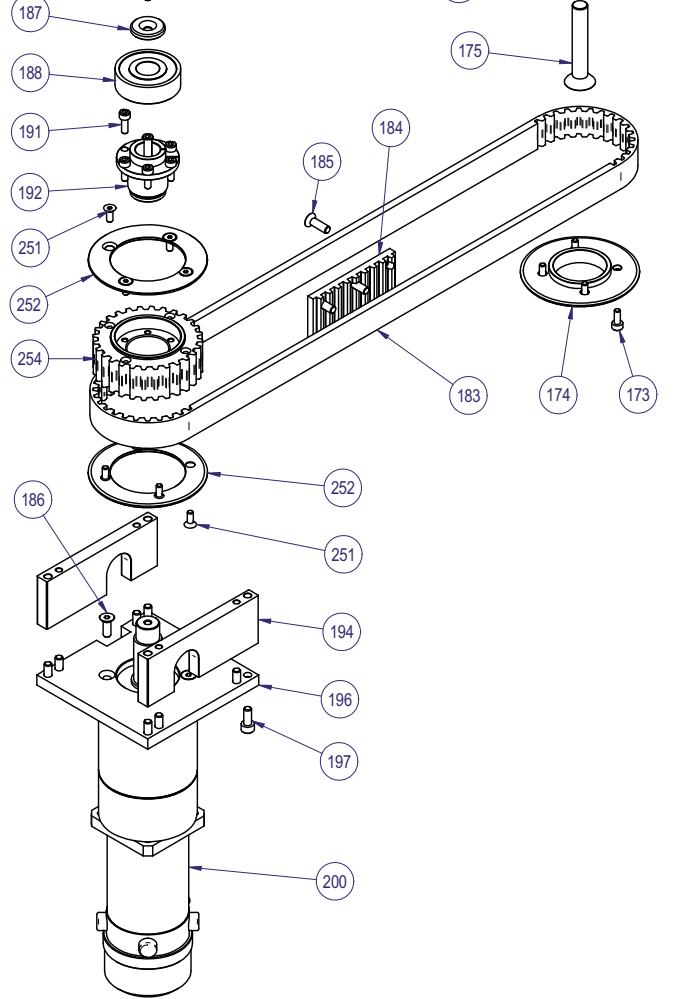

U600 TAB.7 CE MAGAZINE SAFETY GUARD - PROTEZIONE CE MAGAZZINO

*Alfamacchine*  
**10.2015**

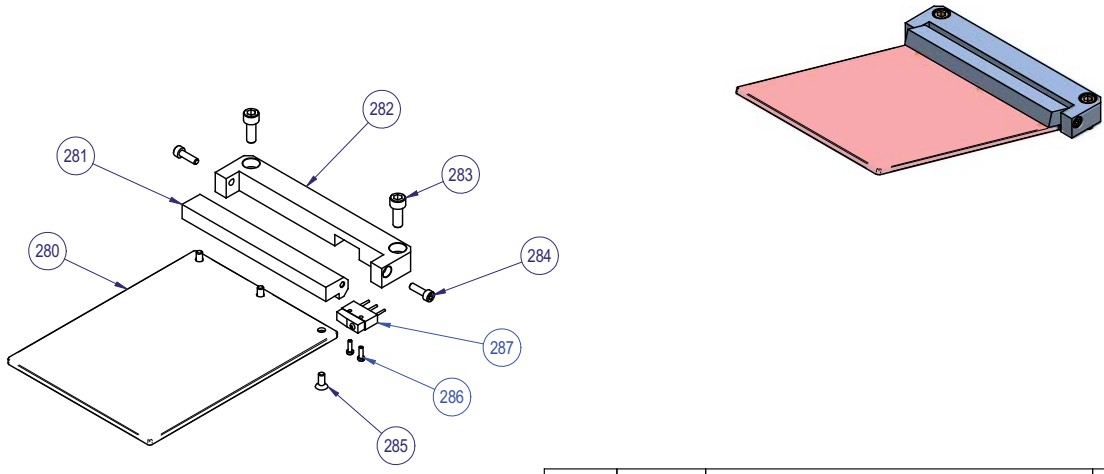

Numero oggetto	Oggetto	Titolo	Quantità
280	398950180	PROTEZIONE POLICARBONATO MAGAZZINO MC	1
281	381301450	SUPPORTO MOBILE PROTEZIONE MAGAZZINO MC	1
282	381301440	SUPPORTO FISSO PROTEZIONE MAGAZZINO MC	1
283	710100075	VITE TCEI M6x16 UNI 5931 8.8 Z.B.	2
284	710100005	VITE TCEI 4x14 UNI 5931 8.8 Z.B.	2
285	710200021	VITE TSPEI 4x10 UNI 5933 10.9 ZB	3
286	710100079	VITE TC M2,5x8 ZB CON TAGLIO DIN84	2
287	817210010	PANASONIC ABS161051 3A 250V	1

U series TAB.8 FRONTAL CLAMP - ASTA A FOGLIA BL. ORIZZONTALE

*Alfamacchine*  
**10.2015**

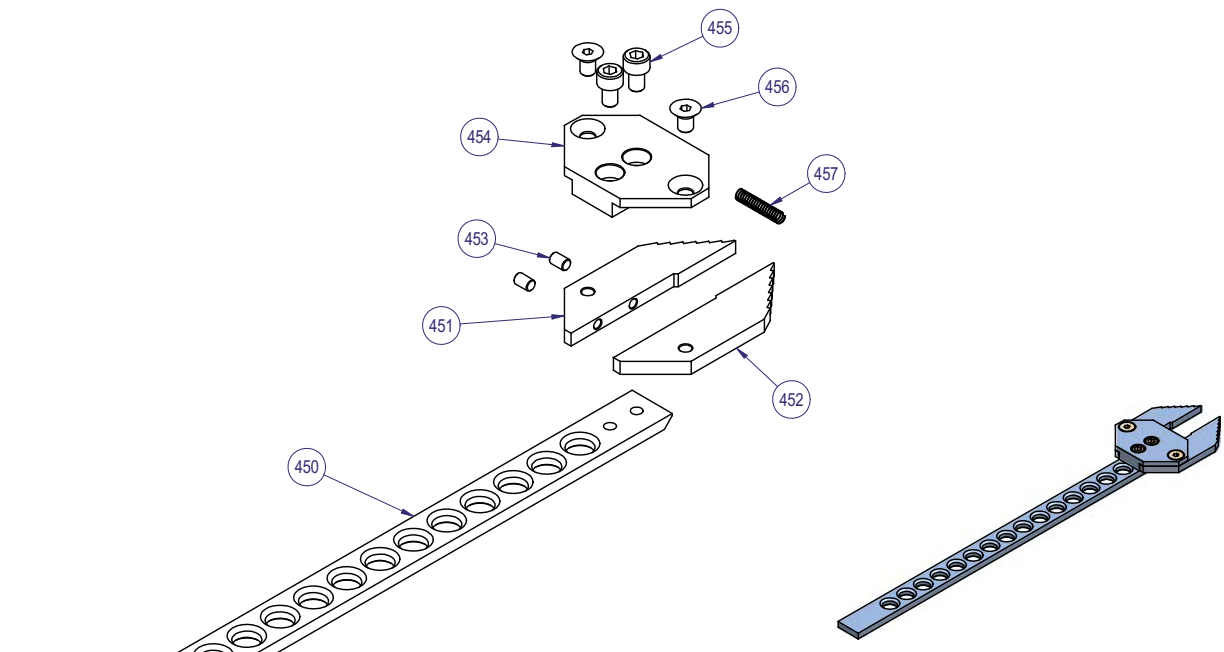

Numero oggetto	Oggetto	Titolo	Quantità
450	384800030	PIATTO ASTA FOGLIA MC-MP	1
451	391950020	"BECCO" DESTRO	1
452	391950030	"BECCO" SINISTRO	1
453	714300063	GRANO STEI 4x6 UNI 5923 14.9	2
454	373400210	PIASTRINA BLOCCAGGIO BECCHI MOBILI DX-SX	1
455	710100052	VITE TCEI M5x8 UNI 5931 8.8 Z.B.	2
456	710200040	VITE TSPEI 5x8 UNI 5933 10.9 Z.B.	2
457	765000002	MOLLA BRACCETTI MOBILI	1

U series TAB.10 VERTICAL CLAMP GROUP - GRUPPO BLOCC. VERTICALE

*Alfamacchine*  
10.2015

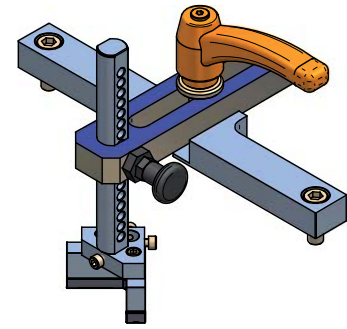
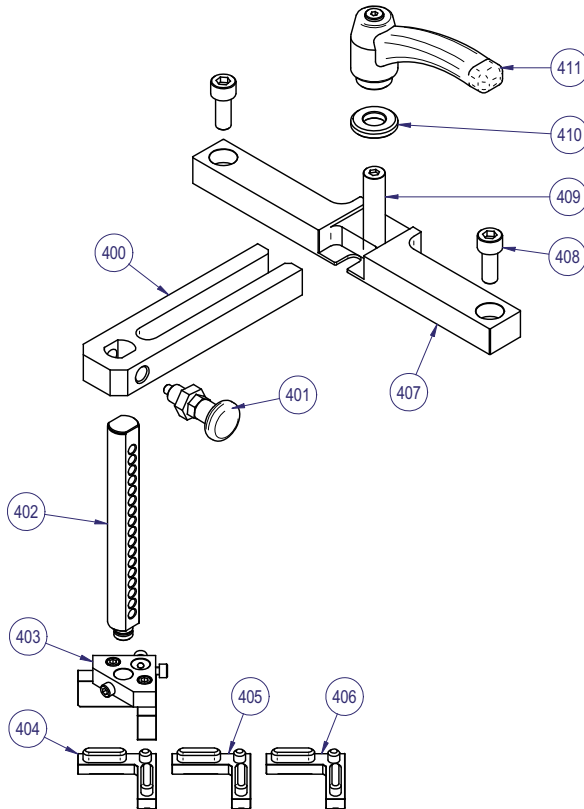

Numero oggetto	Oggetto	Titolo	Quantità
400	383600080	SUPPORTO M4 ASTA BLOCCAGGIO VERTICALE	1
401	753320010	POMELLO CON SPINTORE A MQLA	1
402	334000100	ASTA BLOCCAGGIO VERTICALE PORTATAMPONE	1
403	242230300	TAMPONE ANGOLO COMPLETO	1
404	397100001	PAD L-SHAPED 90 SHORE - BLACK	1
405	397100002	PAD L-SHAPED 75 SHORE - YELLOW	1
406	397100003	PAD L-SHAPED 65 SHORE - BLUE	1
407	376400132	TRAVERSA DOPPIO TAMPONE IDRAULICO MP-MC	1
408	710100151	VITE TCEI M10x25 UNI 5931 8.8 Z.B.	1
409	714300055	GRANO STEI 1/4x60 UNI 5923 14.9	1
410	336100340	RONDELLA DOPPIOTAMPONE IDRAULICO	1
411	753170012	MANIGLIA A-592-94 M14	1

U series TAB.12 CE SAFETY GUARD - PROTEZIONE CE

*Alfamacchine*  
10.2015

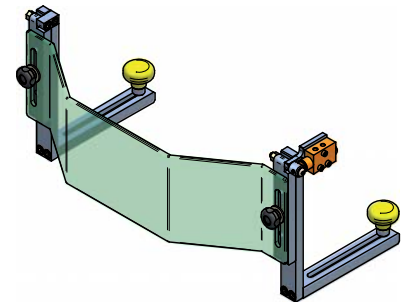
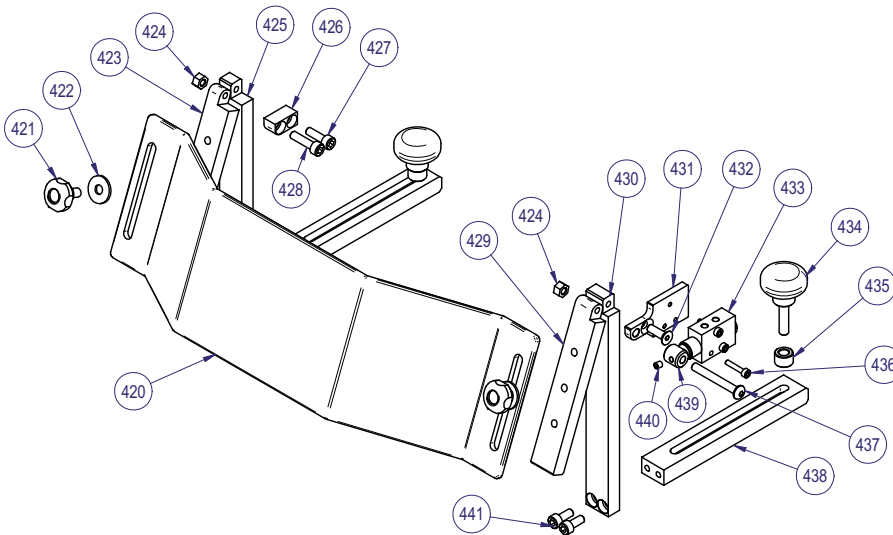

Numero oggetto	Oggetto	Titolo	Quantità	Numero oggetto	Oggetto	Titolo	Quantità
420	398950030	PROTEZIONE CE M4/M6/MC/MCP	1	431	388200020	SUPPORTO VALVOLA PROTEZIONE	1
421	753320009	VOLANTINO D20 M6x10 ZN	2	432	710200055	VITE TSPEI 5x16 UNI 5933 10.9 ZB	1
422	718100015	RONDELLA PIANA M6 UNI 693 6x18 Z.B.	2	433	732540003	MICROVALVOLA 0ALF106.A	1
423	381300190	SUPPORTO SX PROTEZIONE CE	1	434	753320004	POMELLO MASCHIO M6x25	2
424	715650002	DADO M5Medio UNI 5588 6S P.G.Z.B.	2	435	336100020	RONDELLA MORSETTO	2
425	381300200	SUPPORTO FISSO SX PROTEZIONE CE	1	436	710100203	VITE TCEI M3x16 UNI 5931 ZB	3
426	388200030	BLOCCO STAFFA PROTEZIONE CE	1	437	710240013	VITE TBEI M5x40 ZB	1
427	710100045	VITE TCEI M5x16 UNI 5931 8.8 Z.B.	1	438	388200070	SUPPORTO SCORREVOLE PROTEZIONE CE	2
428	710100047	VITE TCEI M5x20 UNI 5931 8.8 Z.B.	1	439	394650020	CAMMA PROTEZIONE	1
429	381300180	SUPPORTO DX PROTEZIONE CE	1	440	714300005	GRANO STEI 4/5 UNI 5927 14.9 A PUNTA	1
430	381300170	SUPPORTO FISSO DX PROTEZIONE CE	1	441	710100043	VITE TCEI M5x12 UNI 5931 8.8 Z.B.	4



U500 TAB.13 HEAD GROUP ASSEMBLY - MONTAGGIO GRUPPO TESTA

*Alfamacchine*  
10.2015

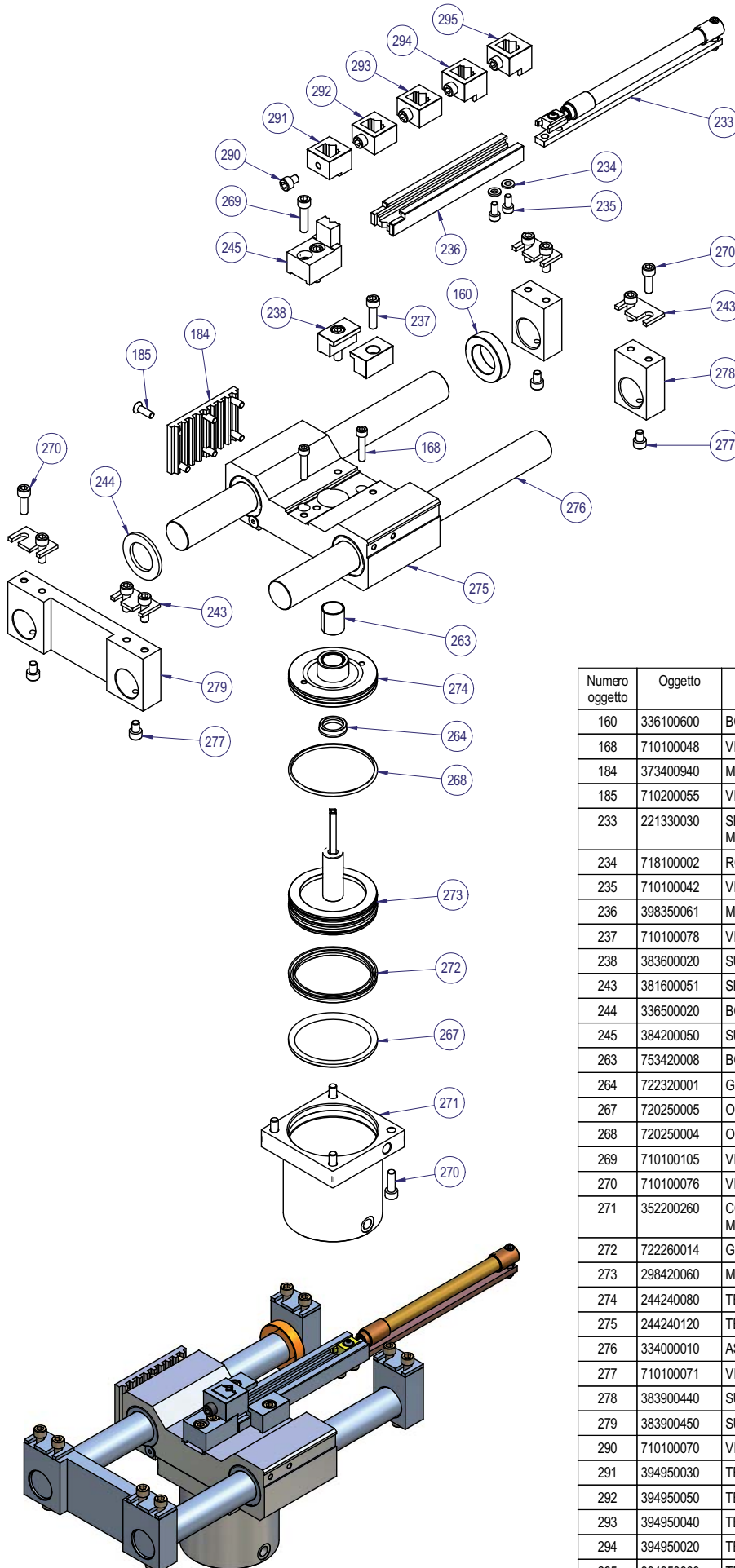

Numero oggetto	Oggetto	Titolo	Quantità
160	336100600	BOCCOLA VULKOLLAN H10 MP	1
168	710100048	VITE TCEI M5x25 UNI 5931 8.8 Z.B.	2
184	373400940	MORSETTO DENT. CINGHIA RPP8 MP-MC	1
185	710200055	VITE TSPEI 5x16 UN 5933 10.9 ZB	6
233	221330030	SPINGIPUNTI COMPLETO LUNGO MEM.PROG.	1
234	718100002	RONDELLA PIANA M5 UNI 6592 5x10 Z.B.	2
235	710100042	VITE TCEI M5x10 UNI 5931 8.8 Z.B.	2
236	398350061	MAGAZZINO GRAFFE	1
237	710100078	VITE TCEI M6x22 UNI 5931 8.8 Z.B.	2
238	383600020	SUPPORTO BLOCCAGGIO CARICATORE	2
243	381600051	SPESSORE H3 MP	4
244	336500020	BOCCOLA VULKOLLAN H3 MP-MC	1
245	384200050	SUPPORTO A L	1
263	753420008	BOCCOLA ALVEOLATA D16 De18 L20	1
264	722320001	GUARNIZIONE A LABBRO DI 062	1
267	720250005	OR 6237 Di59.69 CORDA 5.34 NBR70	1
268	720250004	OR DI. 64,77 CORDA 2,62	1
269	710100105	VITE TCEI M6x25 UNI 5931 8.8 Z.B.	2
270	710100076	VITE TCEI M6x18 UNI 5931 8.8 Z.B.	12
271	352200260	COPPA 80x80 D.70 CILINDRO ESPULSIONE M4-M144-MP	1
272	722260014	GUARNIZIONE A LABBRO M5 7060	1
273	298420060	MARTELLETTO MP - COMPLETO	1
274	244240080	TESTATA SUPERIORE MP - COMPLETA	1
275	244240120	TESTATA SLITTA MP - COMPLETA	1
276	334000010	ASTA D25 L290 MP	2
277	710100071	VITE TCEI M6x8 UNI 5931 8.8 Z.B.	4
278	383900440	SUPPORTO GUIDA POSTERIORE MP	2
279	383900450	SUPPORTO GUIDA ANTERIORE MP	1
290	710100070	VITE TCEI M6x8 UNI 5931 12.9	5
291	394950030	TESTINA H10	1
292	394950050	TESTINA H15	1
293	394950040	TESTINA H12	1
294	394950020	TESTINA H7	1
295	394950060	TESTINA H5	1

U500 TAB.14 HEAD MOTOR GROUP - GRUPPO MOTORE TESTA

Alfamacchine  
10.2015

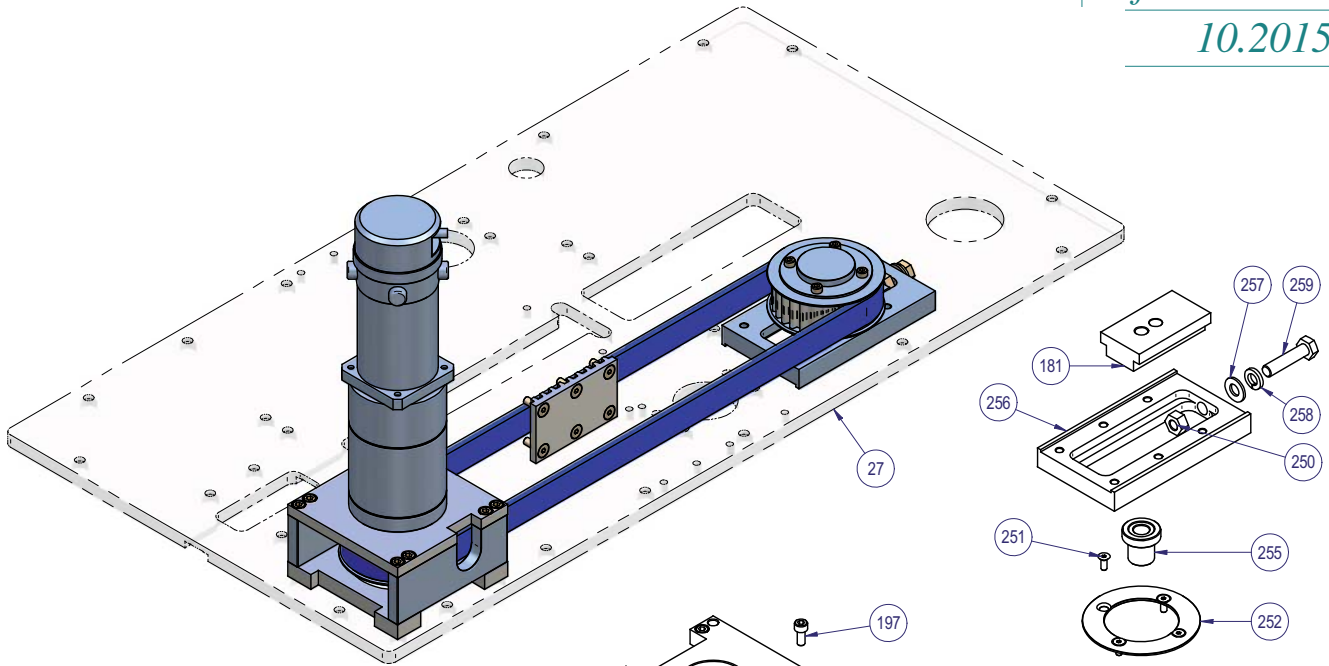

Numero oggetto	Oggetto	Titolo	Quantità
12*	LINGUETTA 5x5x24	LINGUETTA 5x5x24	1
27*	391250191	PIANO MP	1
173	710100003	VITE TCEI 4x10 UNI 5931 8.8 Z.B.	4
174	352600080	COPERCHIO PULEGGIA FOLLE RPP8 MP-MC	1
176	336100010	RONDELLA PULEGGIA OZIOSA MP-MC	1
177	740550031	CUSCINETTO SKF 3203 2RS	1
181	384600091	SUPPORTO T SCORREVOLE TENDICINGHIA MC-MP	1
183	753660036	CINGHIA DENTATA 1000 RPP8 H20	1
184	373400940	MORSETTO DENT. CINGHIA RPP8 MP-MC	1
185	710200055	VITE TSPEI 5x16 UNI 5933 10.9 ZB	6
186	710200056	VITE TSPEI 5x14 UNI 5933 10.9 ZB	5
187	336100380	RONDELLA SCATOLA MOTORE MC-MP	1
188	740550035	CUSCINETTO SKF 6302 2RS	1
190	352600091	COPERCHIO MOTORE MP-MC	1
191	710100031	VITE TCEI M4x12 UNI5931 8.8 ZB	6
192	339000010	CALETTATORE PULEGGIA MOTORE MP-MC	1
194	381301420	FIANCO SCATOLA MOTORE MP-MC	2
196	381301410	SUPPORTO MOTORE MP RPP8 - RE63	1
197	710100043	VITE TCEI M5x12 UNI5931 8.8 Z.B.	12
200	807650090	Motore SIBONI N45M690 + RE63 i:20 RPP8 E C.1,5mt - CABLATO	1
249	710200106	VITE VITE SPEI 10x45 NERA UNI 5933 10.9	1
250	715650004	DADO M8 MEDIO UNI 5588 6S P.G.ZB	1
251	710200021	VITE TSPEI 4x10 UNI 5933 10.9 ZB	12
252	381301430	ALETTA PULEGGIA RPP8 MP-MC	3
253	336000250	PULEGGIA FOLLE TENDICINGHIA MP-MC RPP8 Z28	1
254	336000260	PULEGGIA MOTORE MP-MC RPP8 Z28	1
255	334500110	PERNO SUPPORTO PULEGGIA FOLLE MP	1
256	381300070	SUPPORTO BLOCCAGGIO TENDICINGHIA MP	1
257	718100004	RONDELLA PIANA M8x17 ZB	1
258	718450005	RONDELLA GROVER M8 RINFORZATA ZB	1
259	710600100	VITE TE 8 x 35 UNI 5739 8.8	1

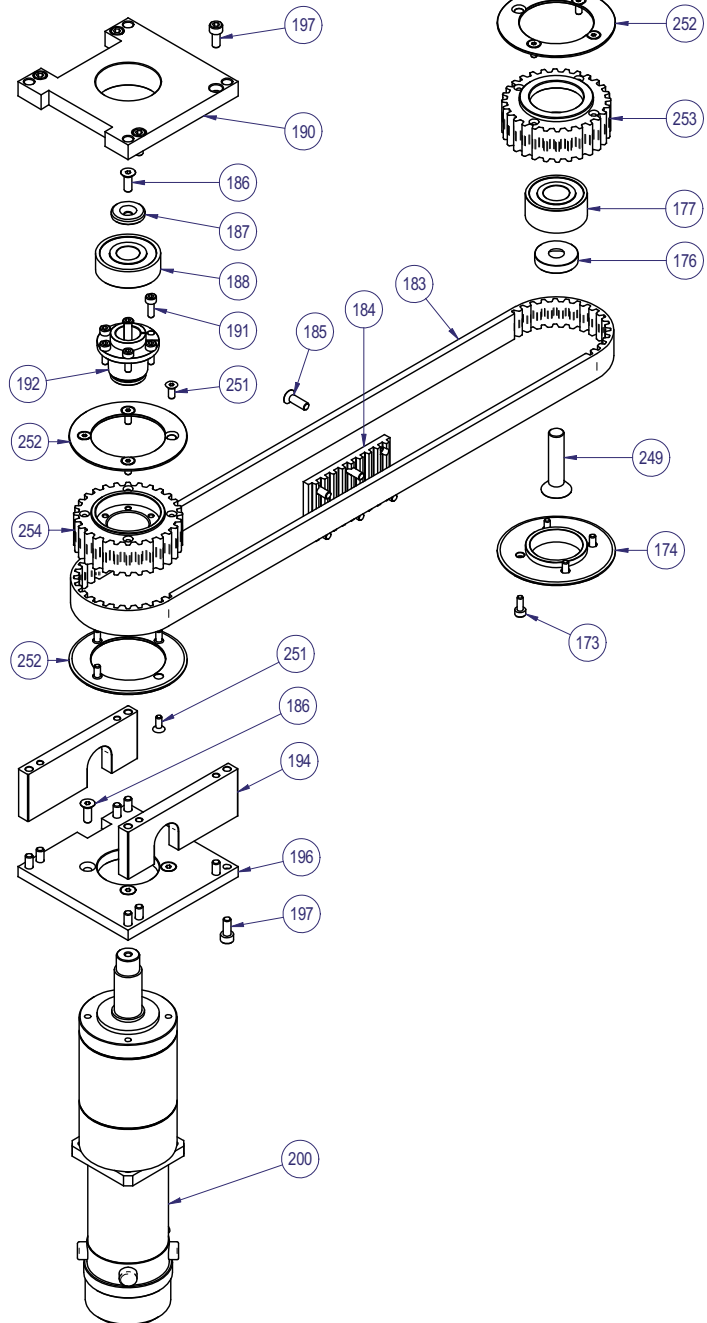

U500	TAB.15A	FLOOR STAND EXPLODED VIEW
U600		ESPLOSO DEL CAVALLETTO

*Alfamacchine*  
10.2015

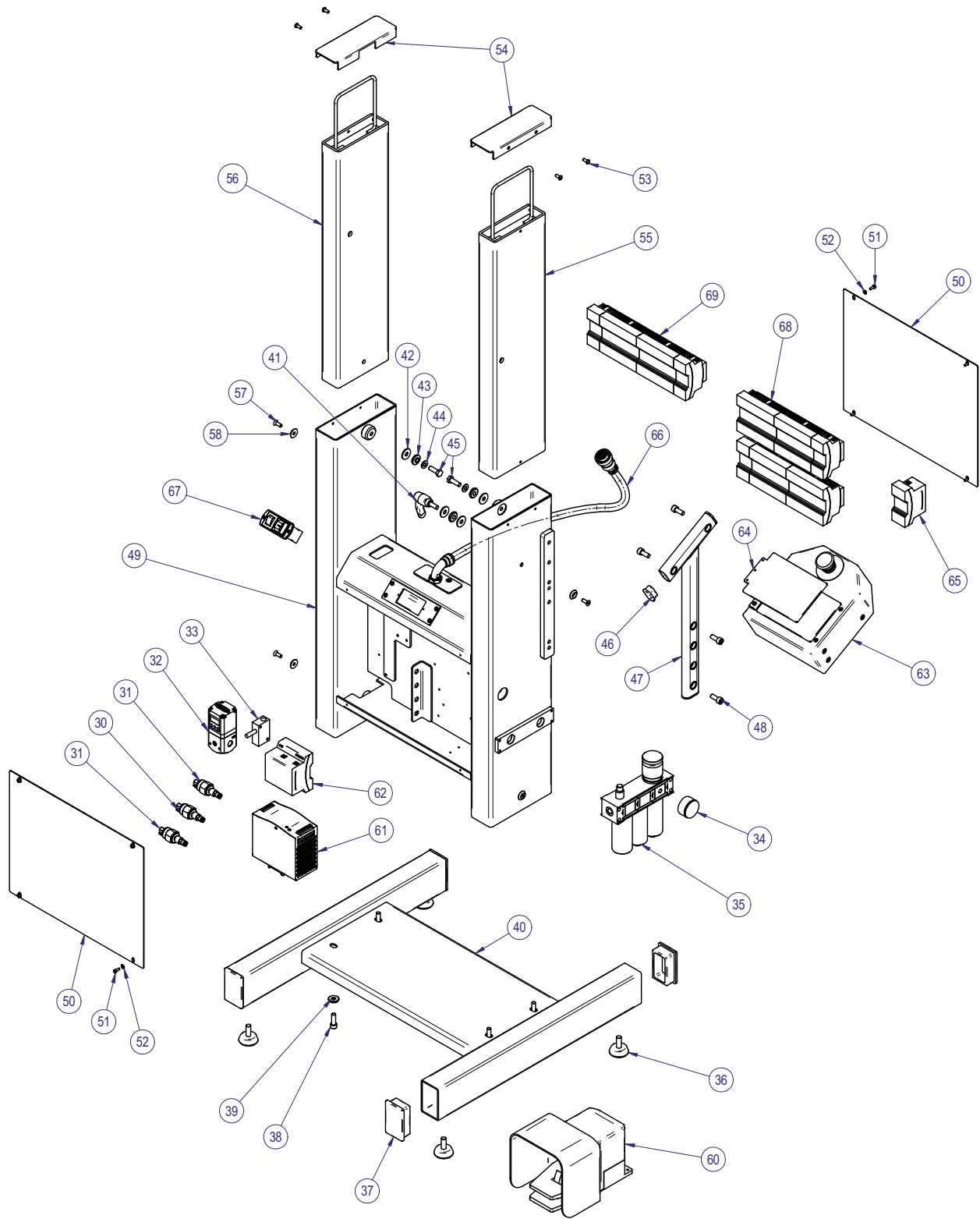

Vedi elenco TAB. 15B.

U500	TAB.15B	FLOOR STAND EXPLODED VIEW
U600		ESPLOSO DEL CAVALLETTO

*Alfamacchine*  
10.2015

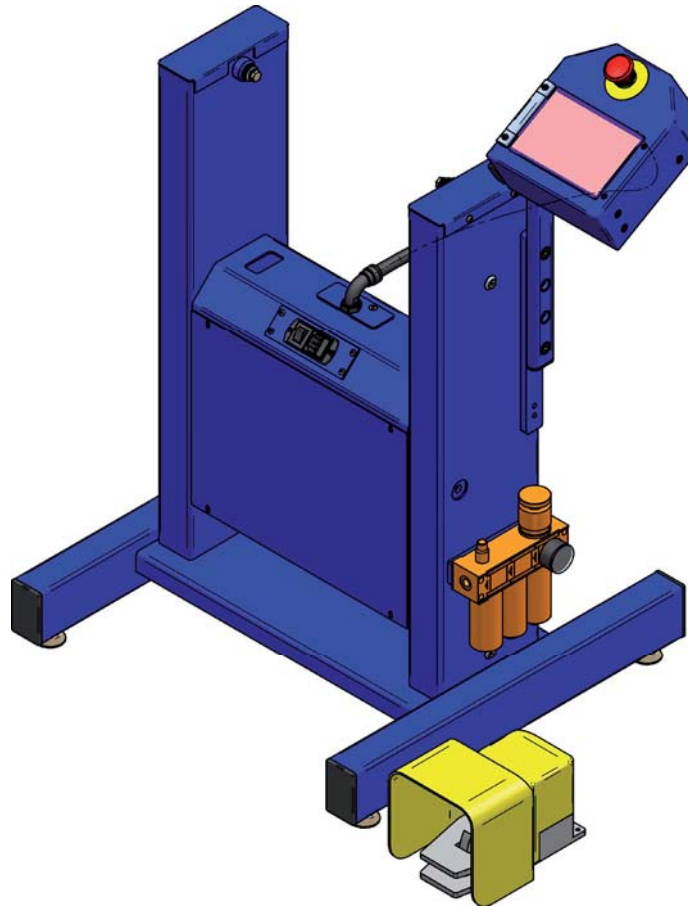

Numero oggetto	Oggetto	Titolo	Quantità	Numero oggetto	Oggetto	Titolo	Quantità
30	735280004	PRESSOSTATO PM10A 1/8 T2,5 BAR ART.922	1	51	710100003	VITE TCEI 4x10 UNI 5931 8.8 Z.B.	2
31	735280003	PRESSOSTATO PM10A 1/8 T3,5 BAR ART.922	2	52	718100001	RONDELLA P.N. M4 UNI 6592 9x4 Z.B.	2
32	732140006	PNEUMAX 171E2N.T.D.0009A	1	53	710240012	VITE TBEI M5x12 ZB	1
33	732140019	Avviatore Progressivo Pneumax 900.14.7	1	54	291800010	CHIUSURA COLONNA	1
34	734230001	MANOMETRO M3A-40 ABS 0-12 BAR 1/8	1	55	291800030	SERBATOIO DESTRO	1
35	735330008	GRUPPO FR 20 08+FS+LUB100 1/4 SK	1	56	291800020	SERBATOIO SINISTRO	1
36	753690010	PIEDINO D.40 M10x25	1	57	710200058	VITE TPSCE 6x16 UNI 5933 10.9 ZB	1
37	810380434	TAPPO PLASTICA NERA 80x50	1	58	336100850	RONDELLA CONICA T350	1
38	710100115	VITE TCEI M8x25 UNI 5931 8.8 Z.B.	1	60	808710010	PEDALE ELETTRICO	1
39	336100140	RONDELLA De22 Di8.25 L4.25	1	61	814000022	MEANWELL SDR240-24V-10A	1
40	291700004	PIEDE CAVALLETTO MP - MC - M4E	1	62	814000021	MEANWELL DR30-15	1
41	753170003	MANIGLIA A-593-80 M8x20	1	63	298390460	KIT KEYPAD EK340 - COMPLETO	1
42	718100016	RONDELLA P.L. M8 x24 Z.B.	1	64	398950181	PROTEZIONE POLICARBONATO DISPLAY TOUCH MP-MC	1
43	336100060	RONDELLA CON RIPRESA PER CAVALLETTO	1	65	814000023	OVP 12A 36VDC	1
44	718100004	RONDELLA PIANA M8x17 ZB	1	66	814000026	CAVO CAN-BUS + ALIMENTAZIONE	1
45	710600102	VITE TE M8x25 UNI 5739 ZB	1	67	813870020	PRESA INT.BIP. + FUSE + FILTRO OMEGA VZ15111	1
46	810380438	TAPPO OVALE OVL40x20x1-3	1	68	EL.MODULES U600	MODULI EUREK CAVALLETTO MC	1
47	352600057	SUPPORTO OVALE CASSETTA DISPLAY TOUCH MP-MC	1	69	EL.MODULES U500	MODULI EUREK CAVALLETTO MP	1
48	710100139	VITE TCEI M8x20 UNI 5931 8.8 Z.B.	1				
49	291800040	NUOVO CAVALLETTO MC-MP-M4E	1				
50	391700014	COPERCHIO	2				





*Alfamacchine*

A Fletcher Company

EN

**ANNEX A**  
**INSTRUCTIONS MANUAL**

PLEASE RETAIN FOR FUTURE REFERENCE

**EN ANNEX A - ORIGINAL INSTRUCTION MANUAL**

**INDEX**

<b>SERVICE CONDITIONS .....</b>	<b>3</b>
<b>ELECTRICAL EQUIPMENT POWER INPUT .....</b>	<b>4</b>
<b>MACHINE CUSTOMIZATION .....</b>	<b>6</b>
Start option (7): .....	7
Automatic head positioning (10): .....	7
Setting the sequence of the mouldings blocking devices (14).....	8
Lock Program Editing setup (19) .....	9
Zeroing commands (22).....	9
Automatic head return (24) .....	9
Configurable magazine (25).....	9
<b>LANGUAGE SELECTION .....</b>	<b>10</b>
<b>SETTING THE DATE AND TIME .....</b>	<b>10</b>
<b>AUTOMATIC ZEROING: .....</b>	<b>10</b>
<b>AUTOMATIC PROGRAM CREATION .....</b>	<b>11</b>
<b>BARCODE FORMATTING.....</b>	<b>11</b>
<b>PERSONALIZED FEATURE.....</b>	<b>11</b>
<b>C.A.P.S. – AUTOMATIC PRESSURE REGULATION SYSTEM.....</b>	<b>12</b>
<b>CAPS ACTIVATION .....</b>	<b>14</b>
<b>SOFTWARE VERSION .....</b>	<b>15</b>
<b>ALARMS AND HISTORY DISPLAY PAGE .....</b>	<b>15</b>
<b>CONTROL CONSOLE CONNECTIONS PANEL.....</b>	<b>16</b>
<b>COPYING A SINGLE PROGRAM ONTO A USB FLASH DRIVE .....</b>	<b>16</b>
<b>TRANSFERRING PROGRAMS ONTO OTHER MACHINES.....</b>	<b>17</b>
<b>CONNECTIVITY WITH WI-FI SYSTEM (optional accessory) .....</b>	<b>18</b>
<b>WI-FI ACTIVATION .....</b>	<b>19</b>
<b>WI-FI DEACTIVATION .....</b>	<b>19</b>
<b>VNC APPLICATION .....</b>	<b>19</b>

 **NOTE:** The topics dealt with in the following annex refer to mechanical, electrical, pneumatic and software updates applied to the machine, consequently they may not match the version in use.  
Check the version of your machine and contact the local after sales service or the manufacturer.

## SERVICE CONDITIONS

SERVICE CONDITION	USER LIMITS
Installation type	Indoor
Floor conditions	Horizontal and smooth: irregularity and gradient tolerance within 2%
Supporting surface characteristics	Flooring in compliance with health and safety requirements in the workplace in accordance with all applicable legislation
Maximum ambient air temperature	+40°C
Minimum ambient air temperature	5°C (with electrical equipment protection rating of at least IP54) 0°C (with electrical equipment protection rating lower than IP54)
Ambient working temperature	+5 °C < T < +45 °C
Transport and storage temperature	between -25°C and +55°C (temperatures of up to +70°C are admissible for periods of less than 24 h)
Maximum altitude above sea level	1000m
Minimum required light intensity	600 lux
Relative humidity of 100% at +25°C (electrical equipment protection rating of at least IP54)	
Relative humidity shall not exceed 50% at +40°C or 90% at +20°C (electrical equipment protection rating below IP54)	
Equipment for machine designed for indoor installations	
Machine NOT suitable for operation in contaminated atmospheres: for example, dusts, acids, corrosive gases, salt or similar contaminants.	
Machine <b>NOT</b> suitable for operating in potentially explosive atmospheres classified as zone 0, zone 1 or zone 2.	
Machine <b>NOT</b> suitable for operation in environments subject to the presence of ionizing and non-ionizing radiation: for example, microwaves, UV rays, laser, X-rays, and similar.	
Electrical equipment NOT suitable for installation on machines or for operation in places subject to vibration and impact: otherwise, install equipment well clear of source of vibration and impact and fit antivibration supports.	
Pollution class of electrical equipment equivalent to 3 (THREE)	
Installation environment equivalent to two (2)	
Can be utilised in residential, commercial, of light industrial zones thanks to compliance with standard EN 61000-6-1	
Intended for direct/exclusive service of industrial process machinery	

SERVICE CONDITION	USER LIMITS
Special and additional prescriptions, not envisaged, may be requested for machines intended for:	<ul style="list-style-type: none"> <li>• outdoor use;</li> <li>• handling potentially explosive materials;</li> <li>• use in potentially explosive and/or flammable atmospheres;</li> <li>• use involving specific risks in the processing of specific materials;</li> <li>• use in mines;</li> <li>• use in refrigeration plants;</li> <li>• use at high temperatures;</li> <li>• use in corrosive environments;</li> <li>• use in strong magnetic fields;</li> <li>• use in radioactive conditions;</li> <li>• use for loads the nature of which could lead to hazardous situations (for example, molten metal, acids/bases, particularly fragile loads, explosives),</li> <li>• use on ships and areas affected by earthquakes;</li> <li>• food-contact use;</li> <li>• use in public areas;</li> <li>• use in aircraft ground support.</li> </ul>

## ELECTRICAL EQUIPMENT POWER INPUT

The main technical characteristics of the machine described in this instruction manual are provided below.

TECHNICAL CHARACTERISTIC TYPE	MANUFACTURER'S WARRANTY	USER LIMITS
<b>ALTERNATE CURRENT POWER SUPPLY</b>		
Nature of the current	1 N PE	
Value at full current load	See wiring diagram $\pm 10\%$	
Rated current value	See wiring diagram $\pm 10\%$	
Rated operating voltage	Ue = AC 110-230V	$\pm 10\%$
Frequency	50-60 Hz	$\pm 1\%$ in continuous mode and $\pm 2\%$ for a brief period
Presumed short circuit current in the point of installation.	6 kA symmetrical	
Recommended position of the power cable		protected in a sheath or raceway
Recommended type of power cable		H07VK NPI 450/750 class 5
Recommended section of the phase conductors		See wiring diagram mm <sup>2</sup>
Recommended section of the neutral conductor		See wiring diagram mm <sup>2</sup>
Prescribed section of the equipotential protection circuit conductor		See wiring diagram mm <sup>2</sup>
Harmonic distortion caused by the cumulative harmonics from the second to the fifth		it must not exceed 10% of the effective value of the total voltage between active conductors
harmonic distortion caused by the cumulative harmonics from the sixth to the thirtieth		it must not exceed 2% of the effective value of the total voltage between active conductors
Negative sequence component and the zero sequence component of the three-phase power supply voltage		They must not be 2% higher than the positive sequence voltage components.
Interruption in the electrical power supply		It must not be interrupted or the voltage must not drop to zero for more than 3 ms. More than 1 second must pass between two successive interruptions.
Voltage dips		Any voltage dips must not exceed 20% of the peak voltage or for more than one cycle. More than 1 second must pass between two successive interruptions.
<b>RATED VOLTAGE/S OF THE AUXILIARY CIRCUITS</b>		
Voltage values	AC - DC 24V	
<b>OPERATING LIMITS</b>		
Short circuit breaking capacity of the overcurrent protection device.	0	
Rated impulse withstand voltage of the power circuits.	Uimp = 2500 V	
Rated impulse withstand voltage of the power circuits	Uimp = 500 V	



TECHNICAL CHARACTERISTIC TYPE	MANUFACTURER'S WARRANTY	USER LIMITS
<b>RECOMMENDED OVERCURRENT PROTECTION DEVICE</b>		
Rated insulation voltage		U <sub>i</sub> = > see the wiring diagram V
Rated current		I <sub>n</sub> = > see the wiring diagram A
Magnetic relay regulation		I <sub>m</sub> = < see the wiring diagram A
Thermal relay regulation		I <sub>m</sub> = see the wiring diagram A
<b>POWER SUPPLY SYSTEMS EARTHING</b>		
EARTH AND NEUTRAL		TT and TN
<b>EQUIPMENT PROTECTION RATING</b>		
Electrical equipment protection rating	IP 54 minimum for components on board the machine IP 54 minimum for casings IP 54 minimum for control actuators	
<b>PROTECTION AGAINST DIRECT AND INDIRECT CONTACTS</b>		
Protection against direct contacts	IP 54 minimum for motors  Protection by means of insulation of active parts; Protection by means of barriers or casings (IP2X -	
Protection against indirect contacts	IPXXB for all components)  Protection through the use of the protection circuit; Protection by means of automatic power supply cut-off	Envisages a protection device for the power supply conductors with an adequate breaking capacity, taking into account a presumed short circuit current in the point of installation of ... kA symmetrical (see the wiring diagram).
<b>INTERNAL DIVISION OF THE EQUIPMENT USING BARRIER OR DIAPHRAGM (necessary IP XXB)</b>		
Segregation	no segregation (form no. 1)	
<b>ELECTRICAL CONNECTIONS OF THE OPERATING UNITS INSIDE THE EQUIPMENT</b>		
For the main inlet circuit	F (fixed connection)	
For the main outlet circuit (if connectors present)	F (fixed connection)	
For the auxiliary circuits (if connectors present)	F (fixed connection) - M (mobile)	
<b>VOLTAGE DROP FROM POWER SUPPLY INLET POINT</b>		
In normal operating conditions	5% less than the rated voltage	

**MACHINE CUSTOMIZATION**

**Pedal options set-up:**

The foot-pedal switch is essential for starting the machine stapling cycle. In the standard configuration the pedal must be pressed down for the entire duration of the cycle. If the pedal is released the operating cycle stops.

The user may customize machine start modes and control the stapling cycle by modifying the pedal setup in accordance with the options listed below:

- Touch the “KEY” icon available both on the “START” page (which appears on machine start-up) (1) and on the “TOOLS” page (2) of the program underway.
- The numerical keypad (3) appears.

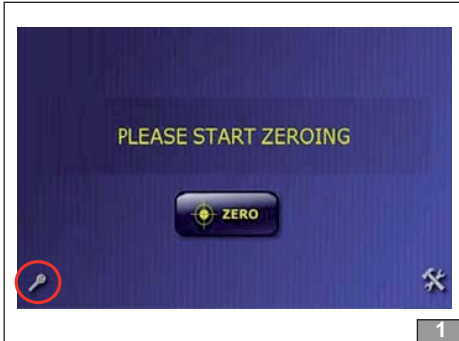

- Enter the password 47122 to access the “machine parameters” page.
- Touch the “PARAMETERS” button to modify the machine configuration (4).

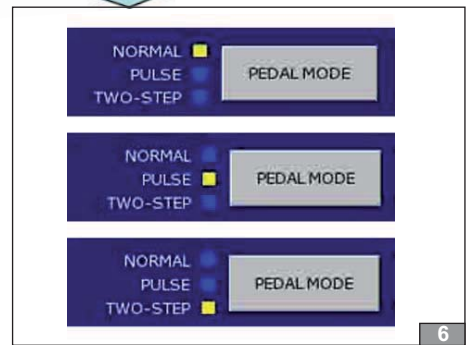
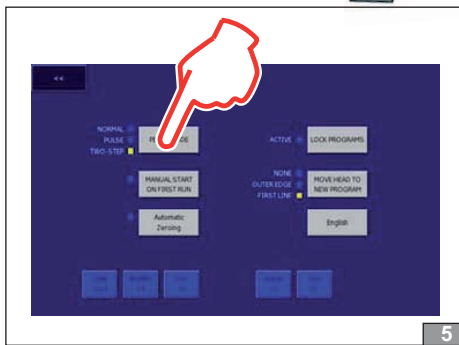
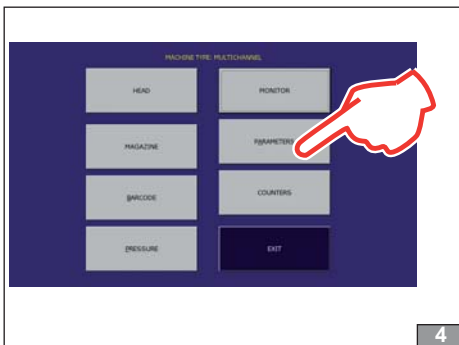

- Touch the “PEDAL MODE” button (5) to modify selection of the pedal’s operating mode (6) and the start-up sequence for the mouldings blocking and stapling cycle.

**NORMAL = keep the Pedal pressed down to run the mouldings blocking and stapling cycle.**

If the operator takes his foot off the pedal before the cycle has been completed the machine will stop immediately.

**PULSE =** simply press the Pedal once to start both mouldings blocking and the stapling cycle.

There is no need for the operator to keep his foot on the pedal throughout the operating cycle.

**TWO-STEP = is a two step operation:**

- 1) Press the Pedal just to block the mouldings in place.  
This operation is used to check the activated blocking angle. If the corner of the frame is not joined in a satisfactory way, stop the cycle by switching machine status from “FULL AUTO” to “START”.
- 2) Release the pedal to start the stapling cycle.

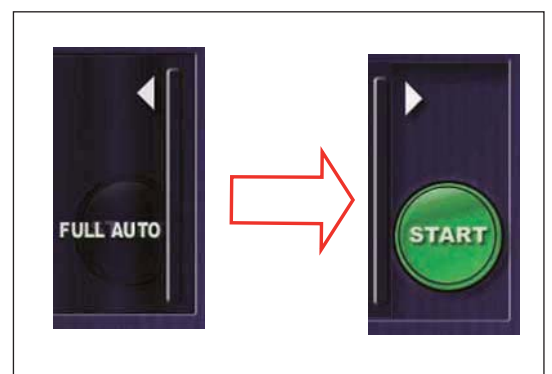

**Start option (7):**

Select the cycle start mode and head positioning.

**MANUAL START ON FIRST RUN = ON (8):** the system sets the cycle start mode to manual (START) every time the user exits the program page or changes program.

In this case, the system requires the operator to check the adjustments of the mouldings blocking system before confirming stapling by touching the “START” button or switching machine status to “FULL AUTO”.

**MANUAL START ON FIRST RUN = OFF (9):** the system automatically switches from the manual “START” status to “FULL AUTO” when the user access the program page or program changeover.

The “FULL AUTO” mode selected determines the quickest way to start the stapling cycle upon pressing the machine pedal, after machine start-up, from program changeover or after maintenance operations, making it unnecessary for the user to intervene on the terminal (GUI). A typical application of this option is to read a barcode with a scanner to change program and then press the pedal to start the stapling cycle.

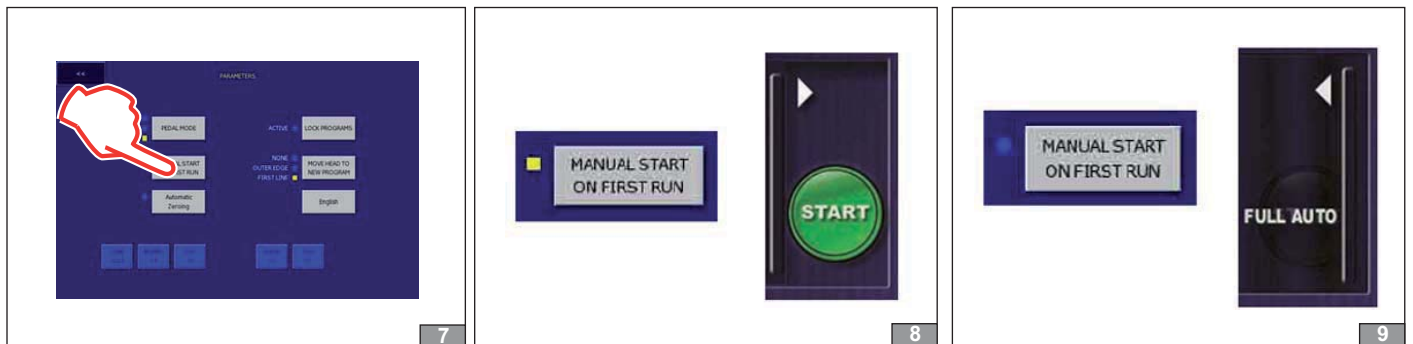

**Automatic head positioning (10):**

The “MOVE HEAD TO NEW PROGRAM” option allows the user to select which operation the head needs to do when the program is changed:

**NONE (11)** = the head remains in its current position when the program is changed:

the user must operate on the screen to move the head and position the front blocking device based on the dimensions of the mouldings.

**OUTER EDGE (12)** = when the program is changed the head automatically moves to the minimum position (where the alignment fences meet):

the user does not have to move the head manually to position the front blocking device in the correct position.

**FIRST LINE (13)** = when the program is changed, the head automatically moves to the first stapling position:

the first position depends on the direction of stapling selected in the program settings in question.

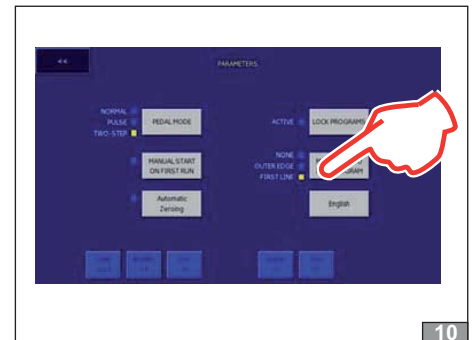

**Setting the sequence of the mouldings blocking devices (14):**

This option allows the user to select the sequence of the mouldings blocking devices. By acting on the 3-position selector on the "TOOLS" page, the user can decide which of the two blocking devices (Vertical or Horizontal) he wishes to activate first or activate them simultaneously. Selecting to activate the blocking devices one after another, at different times, can be very useful in improving the perfect alignment of the frame before it is stapled. On the other hand, selecting to activate the blocking devices simultaneously is recommended when high production speeds are required. Act on the 3-position selector to select one of the following mouldings blocking sequences:

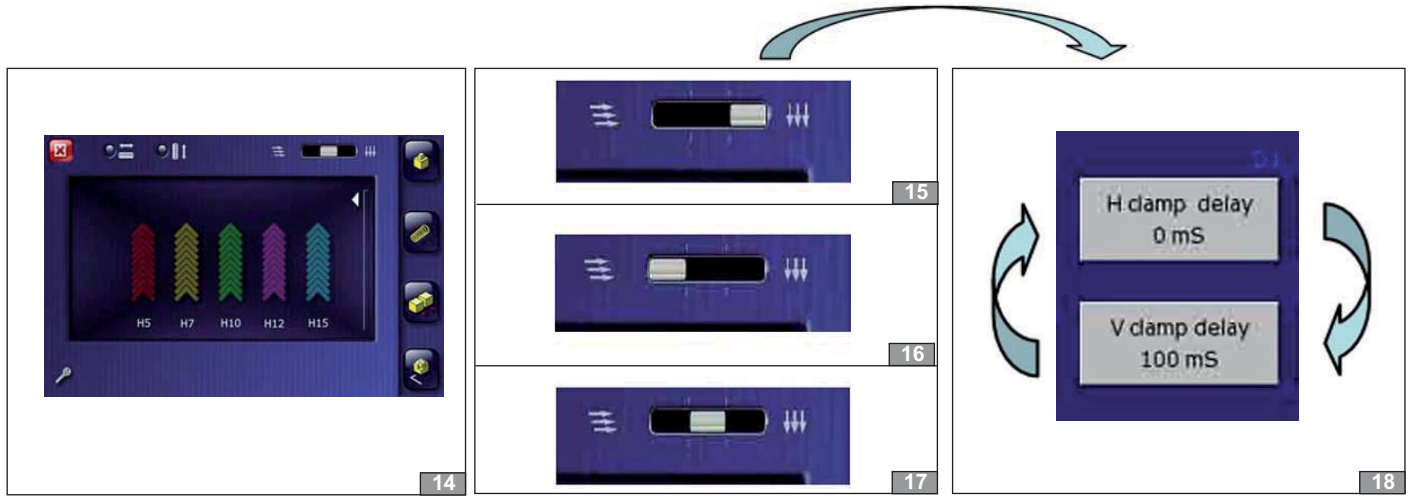

**V-H (15):** selector to the right, activates first the Vertical blocking device and then the Horizontal one.

**H-V (16):** selector to the left, activates first the Horizontal blocking device and then the Vertical one.

**0 (17):** selector in the centre, activates the Vertical and Horizontal locking devices simultaneously.

The delay time for Horizontal and Vertical blocking is set in the "Head" section of the machine parameters (18). (Contact a Technical Service Centre or your local dealer to modify the delay time settings).

**Lock Program Editing setup (19):**

In order to protect the programs and prevent any unauthorized modifications, this option allows only authorized personnel to access the program editing controls and file management. Press the "LOCK PROGRAM" button (20) to enable/disable protection.

When the yellow square is lit up, the following operations are inhibited:		
Creation of new programs	Program renaming	Program import/export
Modifications to existing programs	Barcode renaming	
Program deletion	Stapling direction modifications	

(21) If "LOCK PROGRAM" is active, enter the password 21563 to authorize program editing operations.

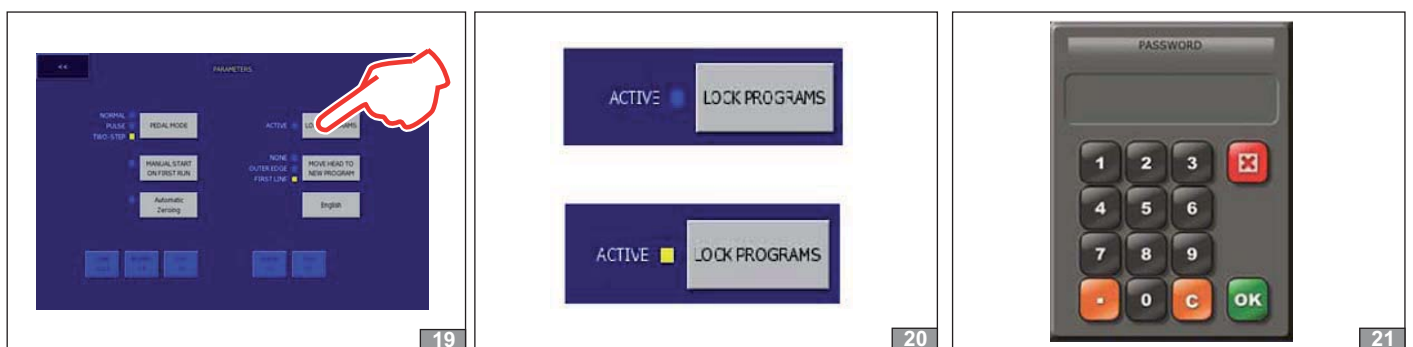



**Zeroing commands (22):**

It is possible to execute the zeroing command for the V-Nail magazine and head motors so as to reset the “zero” references of their positions after maintenance operations or mechanical adjustments have been made.

Touch the “Magazine” or “Head” buttons to command the zeroing sequence (23).

**IMPORTANT:** before executing the “Magazine” zeroing command, make sure that the head is at least 10 mm away from the alignment fences. If this is not the case, move it away manually by acting on the “head maintenance position” button or using the controls on the program page. This minimum distance from the alignment fences is necessary to allow the magazine to be released before it can move.

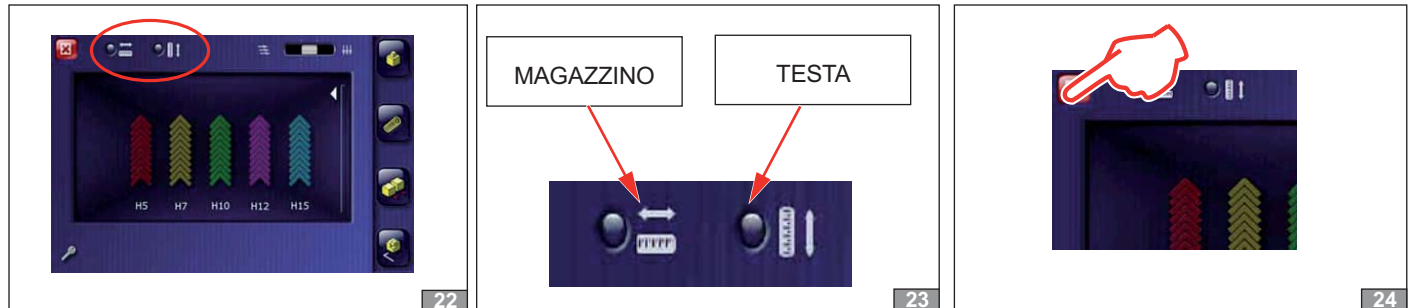

**Automatic head return (24):**

Exiting the tools section (24), the Head automatically returns to the stapling position set in the program if the selection “MOVE HEAD TO NEW PROGRAM” is active.

**Configurable magazine (25):**

This feature is only available if the U600 machine is mechanically built for the configurable magazine. Having a configurable magazine means being able to personalize the height of each channel to match the height of the V-nails you wish to use. This is done by using special adjustment spacers which can be inserted in the magazine channel.

**CUSTOMIZE SLOT SIZES = OFF (27) :** the system does not allow the user to configure the height of the V-nails in the magazine channels and sets the last program setting made.

The standard magazine has 5 channels programmed for all the heights available: H5-H7-H10-H12-H15

**CUSTOMIZE SLOT SIZES = ON (28) :** the system allows the user to program the height of the V-nails for each magazine channel in accordance with the mechanical setup made.

Program each magazine channel in the special display page, taking care to make sure the selected channel matches the actual channel on the magazine (29) (30) (31).

**NOTES**  
- For the U500, disable the option.



## LANGUAGE SELECTION

Press the button (A) as many times as required to reach the language setting you wish to select.

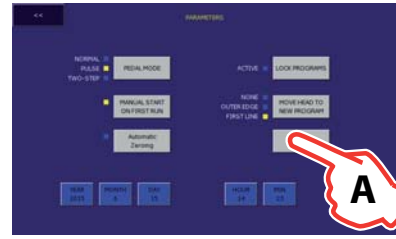

32

## SETTING THE DATE AND TIME

The CPU backup device guarantees operation of the system clock for up to approximately 2 weeks with the machine switched off. Programs, data and configurations on the other hand are never lost. If the machine is switched on after the aforementioned period of time, check and reset the local time and date as follows:

- touch the "triangle" on the work program display (B) to see the alarms page;
- touch the "book" icon (C) to open the alarms history list;
- touch the area showing the time and date (D) to update them;
- in the window which appears, touch the field to be updated and set the new value;
- if one of these fields has been modified, the colour of the characters changes and the OK icon appears to confirm the changes (E);
- the system allows any forward shifting in the date and time but it is not possible to go back more than 15 hours from the date to be changed;
- before confirming, always check the newly set date is correct;
- contact the after sales service if an error is made which cannot be corrected.

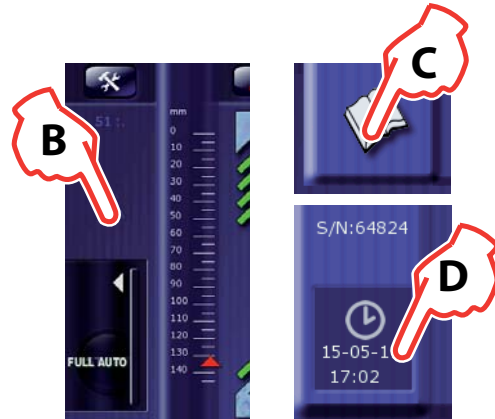

33

### NOTES

- Set the time and date during machine installation;
- The control unit has a date and time backup system which lasts on average for about 40 days with the machine switched off, after which time it is necessary to update the date and time when the machine is switched back on.
- After a long time of machine inactivity (machine switched off) leave the machine on for at least 4 hours to recharge the backup system.



34



35

## AUTOMATIC ZEROING:

In observance of the safety standards, the machine requests confirmation from the operator to start the zeroing sequence by means of the START button.

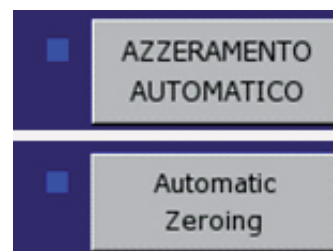

36

## AUTOMATIC PROGRAM CREATION

It is possible to make the machine automatically create the work program by reading a barcode.

The 128 type barcode is generated by software on a PC (available on request) with which the program is edited, as shown in the example. The user can personalize the format of the code by modifying the length of the 3 fields it is made up of.

The central "DATA" field is the one used by the system to enter the program data which must be contained within the set length (minimum recommended = 18 characters).

The HEADER and TRAILER fields on the other hand are for the user to use and are not considered by the system.

It is advisable to zero the number of characters if these 2 fields are not used.

The number of characters set for each field of the code, known as formatting, must correspond with the number set in the machine setup. The maximum total length of the barcode is 40 characters.

The generated barcode can be printed and, for example, associated with the moulding model used in frame production.

The use of this characteristics avoids the creation and storing of programs in the machine as the work program is recreated as required by simply reading the barcode using the special scanner connected to the USB port. Any program created is identified by the name BARCODE.

### EXAMPLE:

1. Program made on the PC and generation of the barcode;
2. Scanning of the barcode to create the program on the machine



37

## BARCODE FORMATTING

Barcode formatting is used by the system to identify the format of the barcode to be read.

If the code formatting read matches the one configured on the machine the program is created.

On the other hand, if it is not recognized the system uses the code read to search for the program in its memory.

To modify formatting:

- touch the "Barcode" button (A) in the service menu to see the 3 fields for formatting the code;
- touch the button corresponding to the field in which you wish to modify the length of characters;
- using the numerical keypad, enter the number of characters and press OK to confirm.



38



39

## PERSONALIZED FEATURE

Automatic creation of the program by barcode reading (EAN128):

The system can automatically create a program, named "BARCODE" by reading an EAN18 type barcode of a length of between 23 - 39 characters.

The data of the program is defined in accordance with specific code formatting.

Codes with more than 39 characters or less than 23 are discarded (code not valid) so that the system considers it a normal "program name" to be searched for in its memory and not to be created.

**C.A.P.S. – AUTOMATIC PRESSURE REGULATION SYSTEM**

The electronic pressure regulator (CAPS) is a device which automatically adjusts the clamping pressure thus eliminating the need for manual interventions by the operator. The pressure is set and memorized in each program by means of the special interface on the screen.

Set the Pressure of the CAPS clamping system: From the main program, touch the icon to select the speed and pressure (A).

To select the pressure touch the value on the graduated scale of the pressure gauge (B) shown on the display.

The red dot indicates the set pressure, the value of which can also be read on the machine’s pressure gauge.

The scale of available pressure values is divided into three different colour zones for quick and easy selection of the pressure based on the hardness of the material being joined, as indicated in the table.

The harder the material the higher the clamping pressure must be to avoid movement when the V-nails are being inserted.



40

Durezza / Hardness	Pressione consigliata / Air Pressure
Soft Clamp Soft Clamp	2 bar / 30 psi
Legni Morbidi Soft Wood	3 bar / 43 psi
	4 bar / 58 psi
Medium/Hard Wood Medium/Hard Wood	5 bar / 72 psi
	6 bar / 87 psi
Legni Molto Duri Very Hard Wood	7 bar / 100 psi
	8 bar / 115 psi



41



42

**Soft clamp**

This function minimizes the impact of the vertical clamp unit against the surface of the moulding during the clamping operation. The initial pressure is set at 2 bar (30 psi) and switches to the set pressure during V-nail insertion.

Touch “soft clamp” to activate/deactivate this option.

“Soft clamp” is particularly suitable for:

- Very soft materials;
- Surfaces with very delicate coatings (stucco or plaster decorations), whatever the hardness of the material.

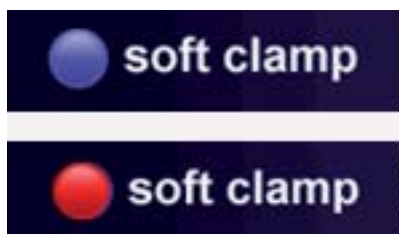



43

Soft clamp deactivated, the pressure is not reduced when the blocking device is activated.

Soft clamp activated, the pressure is reduced when the blocking device is activated.

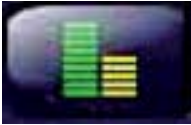

IMAGE	ASPECT	METHODS AND RESULTS
	The stapling speed icon shows only one column.	The automatic pressure regulator is not active or is not available.
	The stapling speed icon shows two columns.	Column 1 on the right shows the nailing speed level. Column 2 on the left shows the clamping pressure level.
	The stapling speed icon shows two columns and a red triangle.	Columns 1 and 2 show the level set for the stapling speed and the clamping pressure. The red triangle appears when there is an alarm condition. - insufficient operating pressure; - the pressure supplied to the machine is lower than the pressure to be regulated; - the pressure reached signal from the regulator is not working.
	The clamping system pressure is 0 even when correctly programmed.	- Emergency condition or emergency stop button pressed. - The EC safeguard is open. - The pressure regulator cable is disconnected or broken. - The 24V power supply is switched off. - The codified outputs are not working. - The electronic pressure regulator is not configured. - The machine is switched off.
	The pressure reading on the pressure gauge is not the same as the set pressure.	- Check the pressure gauge. - The set value is being rounded down to the nearest value in the device's configuration table. - The CAPS has not been configured correctly. - The system is regulated for a precision of 0.2 bar (3 psi), greater precision is not necessary.

Contact the after sales service to:

- configure the CAPS for pressure values different to the standard ones;
- configure the electronic pressure regulator;
- activate the CAPS on machines where it was not installed, available from the "firmware-1\_11\_28\_2014Dec23-155235" version;
- check the possibility of installing CAPS on an older machine;
- CAPS can only be installed on the latest versions of electronic machines with a touchscreen display.

**NOTES**

- If you import programs in which the CAPS was not installed, the system will set the default value of Medium pressure.
- When you create a new program, the clamping pressure is set at the default value of Medium pressure.
- Control of the clamping system pressure has no effect on the air pressure used to insert the V-nails.
- The preset pressure values are suitable for working with the materials handled so far, should it be necessary to use pressure values which are not included in the envisaged range, please contact your local dealer or manufacturer for instructions.

**CAPS ACTIVATION**

- Enter the right password to access the machine setup menu.
- Touch the "PRESSURE" button to see the automatic pressure control configuration page.
- Touch the "PRESSURE CONTROL" button to use the device.



44

Pressure values table

mB LEVEL 1	2000mB
mB LEVEL 2	3000mB
mB LEVEL 3	4000mB
mB LEVEL 4	5000mB
mB LEVEL 5	6000mB
mB LEVEL 6	7000mB
mB LEVEL 7	8000mB

45



46

**NOTES**

- Do not modify the pressure levels table.
- Do not modify the electronic regulator's configuration.
- Contact the after sales service should it be necessary to modify the pressure levels table.

Deactivated



47

Activated



48

Pressure control



49



50

## SOFTWARE VERSION

Access the alarms history page for information on the software version installed.  
Contact the after sales service for the updating procedure.



54

## ALARMS AND HISTORY DISPLAY PAGE

Touch the “triangle” on the work program display (A) to see the alarms page.

The presence of an alarm condition is indicated on the screen by the appearance of a hazard triangle displayed as follows:

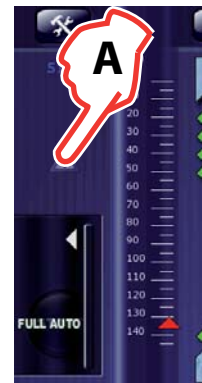

55



no alarm (transparent grey triangle)



process alarm with automatic reset (yellow triangle)



critical alarm needing operator intervention (red triangle)

Touch the triangle to open the alarm message and find out the relative cause of the active alarm. If there is more than one active alarm they are displayed in sequence.

Touch the “book” icon (B) to open the alarms history list.

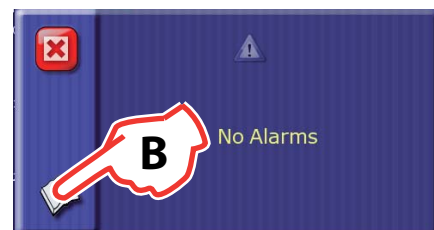

56

**CONTROL CONSOLE CONNECTIONS PANEL**

- 1- power supply and Can-Bus connector
- 2- Wi-Fi antenna connector (if installed)
- 3- Type A USB ports
- 4- RJ45 socket, optional
- 5- Connectors layout label
- 6- SN and MAC identification label.

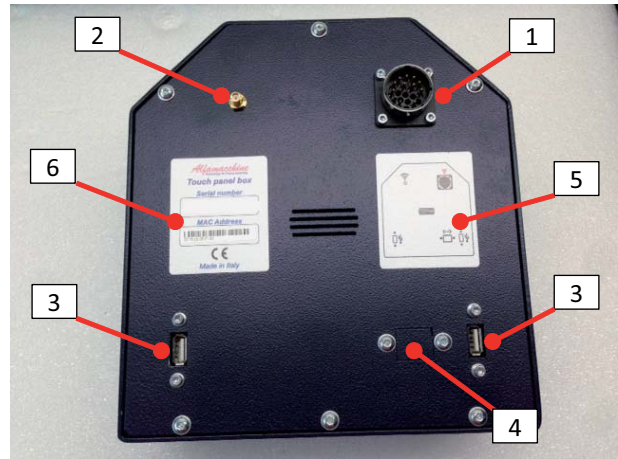

57

**COPYING A SINGLE PROGRAM ONTO A USB FLASH DRIVE**

- On the main program page, touch the field with the program name to access the list of programs.
- Insert an empty USB flash drive into one of the available ports.
- Select the program you wish to copy to call up the list of “info” commands.
- Touch the “USB” icon to copy the selected program onto the flash drive.
- A confirmation message appears when copying has been completed.
- The saved program can now be copied onto another machine by reading it after entering the “222111” password.



58



59

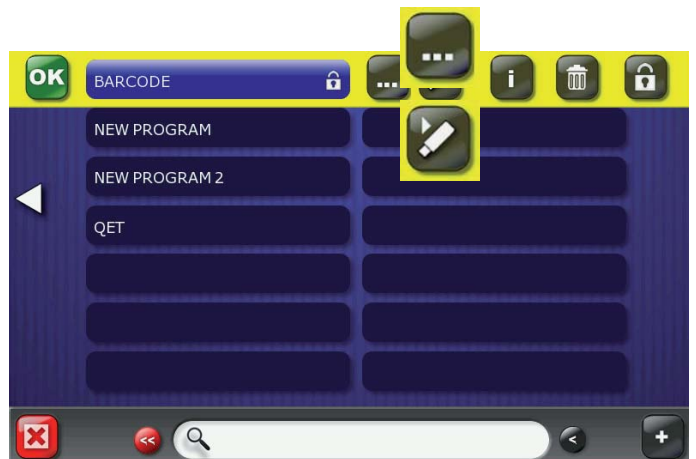

60



## TRANSFERRING PROGRAMS ONTO OTHER MACHINES

### Copy:

It is possible to quickly and easily transfer programs created on one machine to other machines using a USB flash drive.

- Insert the empty USB flash drive into one of the available ports.
- Touch the “key” icon and enter the writing code “111222” using the numerical keypad.
- Press OK to confirm and start the copying process of all the programs (backup) onto the flash drive.
- Once the operation has been completed, a message will appear indicating the number of programs copied.



61

### Reading:

- Insert the flash drive holding all the programs in the USB port and enter the reading code “222111”.



62



**WI-FI ACTIVATION**

*Application not envisaged on the Standard model.  
Contact your supplier for methods of use and setup.  
Ask the supplier if the WI-FI option has been installed on the control card.*

- Touch the "key" icon and enter the Wi-Fi activation code (ask your local dealer for the code).
- The access points detected near the machine will be displayed. Select the one you wish to connect up to.
- Touch the "Connect" button to activate the connection.
- Enter the Access Point identification password.

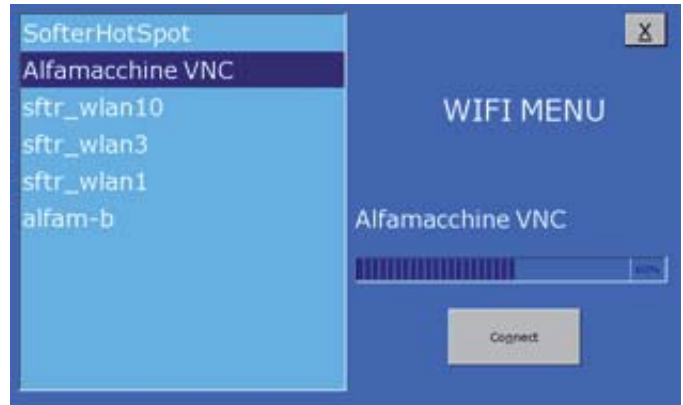

**WI-FI DEACTIVATION**

- Touch the "key" icon and enter the deactivation code (ask your local dealer for the code).
- A message asking for the system to be rebooted appears.

**VNC APPLICATION**

The VNC application is a function which makes it possible to connect a remote device (iphone, ipad, tablet, PC, etc,) to a single machine for which access has been made. From the Internet it is possible to download free applications for installation on the remote device which allow you to view the user interface on which you wish to operate.

- The browsing speed and graphic display will depend on the App performance and not on the machine.
- Activate a Wi-Fi connection.
- Touch the "key" icon and enter the VNC activation code (ask your local dealer for the code).
- A message will request a system reboot.
- Provide the network addresses needed by the user for the remote connection.
- Configure the App on the remote device for the IP address of the user with which you wish to connect.
- deactivate the VNC if not used.



*NOTES*  
*during remote access in VNC mode, the machine must not be used for production;  
supervision by a maintenance technician is required as all functions are controlled in remote mode.*

**Show the addresses to identify the on-line machine and Wi-Fi:**

Touch the "key" icon and enter the code "0" to show all the information necessary to identify the electronic card for the connection. The following addresses will be displayed in sequence:

MAC: 00:1b:c5:08:d1:16

NO IP

MAC: 00:07:80:01:99:b3

WIFI IP: 10.0.1.5 WIFI IP6: fe80::207:80ff:fe16:11c8



IP address to configure the VNC remote terminal



**ALFAMACCHINE S.r.l.**  
Via Selva, 23/25 - 47122 Forlì - FC -  
Tel. +39-0543/783301 Fax +39-0543/783302  
<http://www.alfamacchine.com>